

Saves Wiring Effort, Production Steps, and Time

- Easy wiring ensured through the Quick-connect Terminals.
- External actuator mounts in either of two directions.
- Horizontal layout of terminals saves mounting space.
- Same internal mechanism as the OMRON SS Subminiature Basic Switch.



Ordering Information

Actuator	Actuator mounting position		Contact type	Model
Pin plunger	---		SPST-NC	D3M-01
			SPST-NO	D3M-01-3
Hinge lever	K		SPST-NC	D3M-01K1
			SPST-NO	D3M-01K1-3
	L		SPST-NC	D3M-01L1
			SPST-NO	D3M-01L1-3
Hinge roller lever	K		SPST-NC	D3M-01K2
			SPST-NO	D3M-01K2-3
	L		SPST-NC	D3M-01L2
			SPST-NO	D3M-01L2-3
Simulated hinge lever	K		SPST-NC	D3M-01K3
			SPST-NO	D3M-01K3-3
	L		SPST-NC	D3M-01L3
			SPST-NO	D3M-01L3-3

■ Model Number Legend

D3M-01□□□
 1 2 3

1. Actuator Mounting Position

None: No actuator

K: Pushbutton close to actuator fulcrum

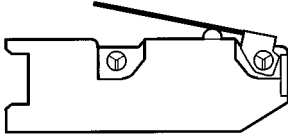

L: Pushbutton far from actuator fulcrum

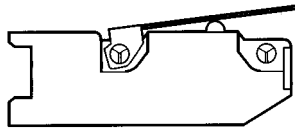

2. Actuator Type

None: Pin plunger

1: Hinge lever

2: Hinge roller lever

3: Simulated hinge lever

3. Contact Specification

None: SPST-NC (with red pushbutton)

-3: SPST-NO (with black pushbutton)

■ Connectors

Refer to *Wiring* on page 7 for details.

Specifications

■ Ratings

Rated voltage	Resistive load
30 VDC	0.1 A

Use the D3M in the following permissible operating range.

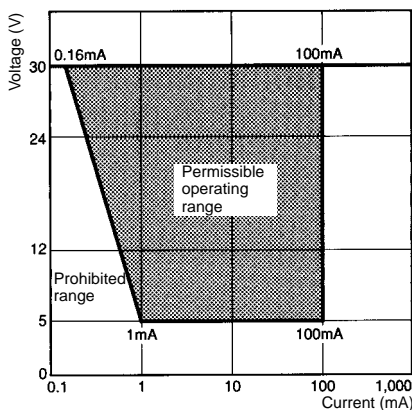

Minimum Applicable Load (Level N)

Voltage	Resistive load
5 VDC	1 mA

Refer to *Minute Load* on page 7 for details.

■ Approved Standards

EN61058-1

UL1054

CSA C22.2 No.55

■ Contact Form

SPST-NC

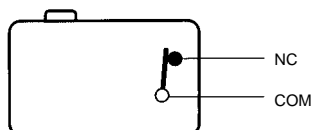

SPST-NO

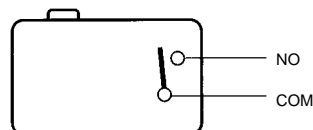

■ Characteristics

Permissible operating speed (see note 1)		0.1 mm/s to 1 m/s
Permissible operating frequency	Mechanical	400 operations/min max.
	Electrical	60 operations/min max.
Insulation resistance		100 M Ω min. at 500 VDC
Contact resistance (initial value)		100 m Ω max. including connector and 50-mm AWG28 lead wire resistance
Dielectric strength	Between terminals of the same polarity	1,000 VAC at 50/60 Hz for 1 min
	Between charged metal part and ground	1,500 VAC at 50/60 Hz for 1 min
	Between non-charged metal part and each terminal	1,500 VAC at 50/60 Hz for 1 min
Vibration resistance	Malfunction (see note 2)	10 to 55 Hz, 1.5-mm double amplitude for 1 ms max. with contacts closed or open.
Shock resistance	Destruction	1,000 m/s ² (approx. 100G)
	Malfunction (see note 2)	300 m/s ² (approx. 30G) for 1 ms max. with contacts closed or open.
Life expectancy	Mechanical	500,000 operations (at full-stroke operating speed of 10 mm/s at a frequency of 60 operations/min)
	Electrical	200,000 times (at full-stroke operating speed of 10 mm/s at a frequency of 30 operations/min)
Enclosure rating		IP00
Degree of protection against electric shock		Class I
Proof tracking index (PTI)		175
Ambient temperature	Operating	-25°C to 85°C (with no icing)
Ambient humidity	Operating	85% max.
Weight		Approx. 2 g (pin plunger model)

- Note:**
1. The permissible operating speed applies to pin plunger models.
 2. If a lever actuator model is used, the above vibration resistance conditions will apply on condition that the actuator is in the maximum overtravel position.

■ Contact Specifications

Contact	Cross bar
Material	Gold alloy
Distance between contacts	0.5 mm

Dimensions

Note: All units are in millimeters unless otherwise indicated.

■ Mounting Dimensions

Mounting

Use M2.3 screws, flat washers, and spring washers to mount the D3M securely. Make sure that the tightening torque applied to each screw is within a range from 0.23 to 0.26 N·m (2.3 to 2.7 kgf·cm).

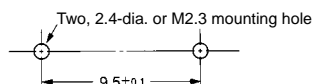

■ Operating Characteristics
Pin Plunger Models

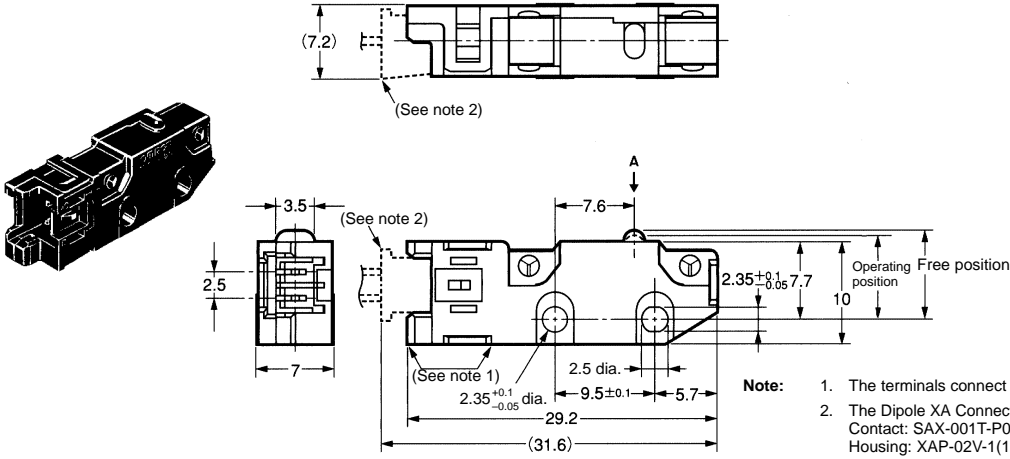

Operating characteristics	D3M-01, D3M-01-3
Max. operating force (OF)	1.50 N {153 gf}
Min. reset force (RF)	0.25 N {25 gf}
Min. pretravel (PT)	0.6 mm
Min. overtravel (OT)	0.4 mm
Max. movement differential (MD)	0.1 mm
Operating position (OP)	8.4±0.3 mm

Hinge Lever Models

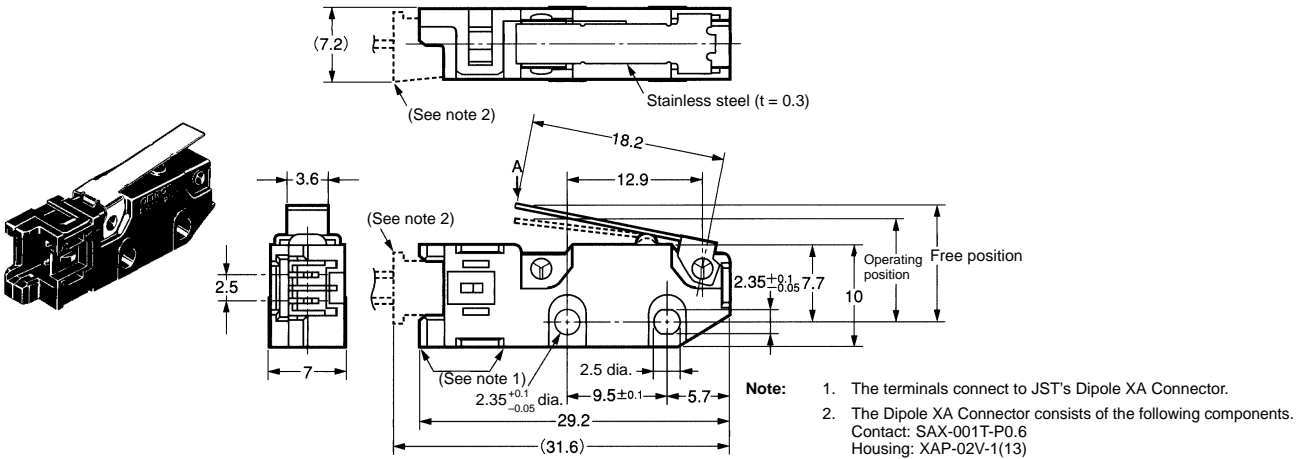

Operating characteristics	D3M-01K1, D3M-01K1-3
Max. operating force (OF)	0.50 N {51 gf}
Min. reset force (RF)	0.06 N {6 gf}
Min. overtravel (OT)	1.2 mm
Max. movement differential (MD)	0.8 mm
Max. free position (FP)	14.0 mm
Operating position (OP)	10.0±0.8 mm

Note: 1. A tolerance of ±0.4 mm applies to all the above dimensions unless otherwise specified.
2. The operating characteristics apply on condition that each actuator is moved in the direction indicated by the arrow and "A."

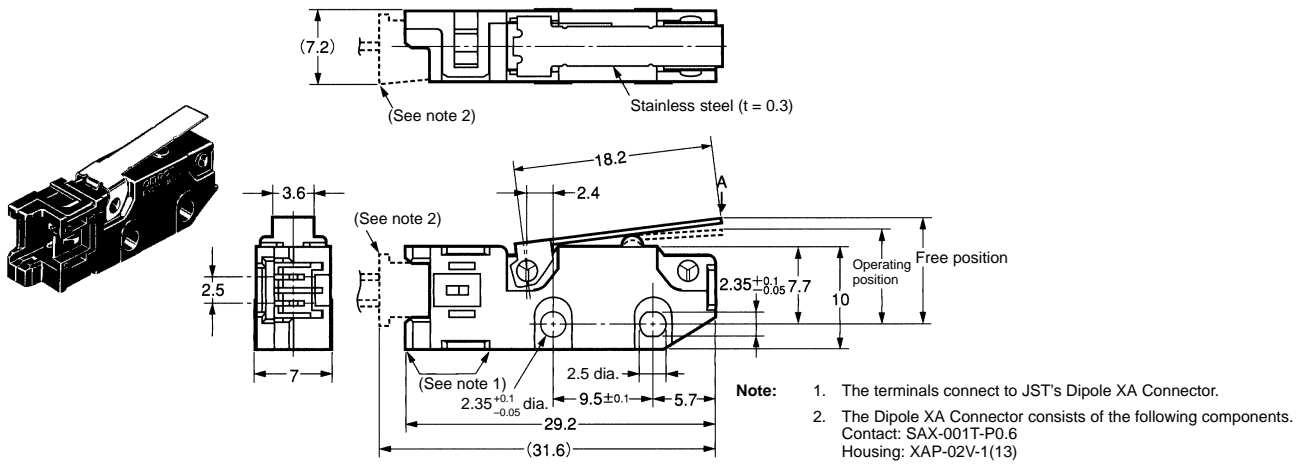

Operating characteristics	D3M-01L1, D3M-01L1-3
Max. operating force (OF)	1.00 N {102 gf}
Min. reset force (RF)	0.10 N {10 gf}
Min. overtravel (OT)	0.7 mm
Max. movement differential (MD)	0.6 mm
Max. free position (FP)	11.5 mm
Operating position (OP)	9.2 ± 0.6 mm

Hinge Roller Lever Models

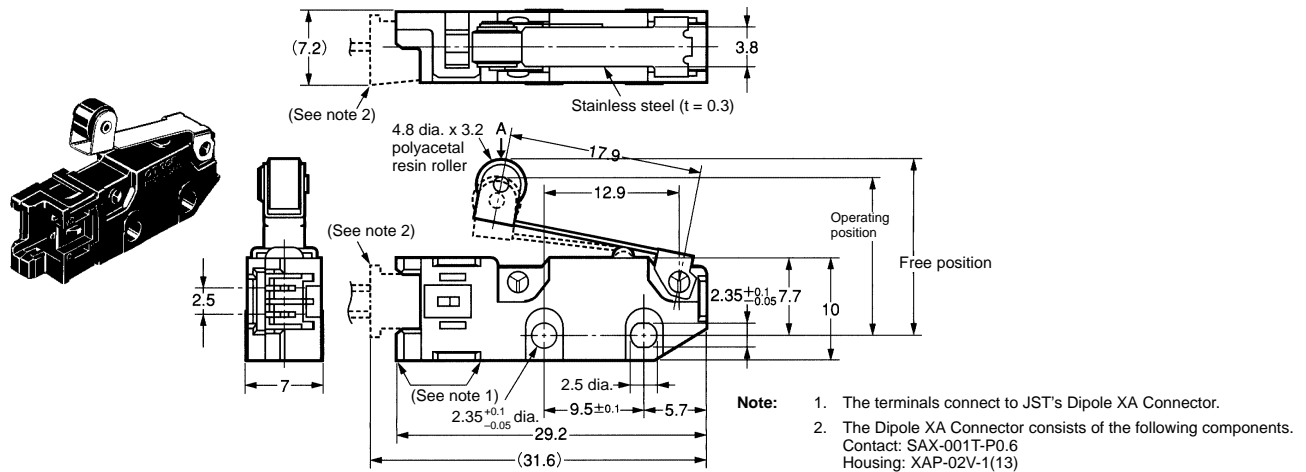

Operating characteristics	D3M-01K2, D3M-01J2-3
Max. operating force (OF)	0.50 N {51 gf}
Min. reset force (RF)	0.06 N {6 gf}
Min. overtravel (OT)	1.2 mm
Max. movement differential (MD)	0.8 mm
Max. free position (FP)	19.7 mm
Operating position (OP)	15.7 ± 0.8 mm

Note:

1. A tolerance of ±0.4 mm applies to all the above dimensions unless otherwise specified.
2. The operating characteristics apply on condition that each actuator is moved in the direction indicated by the arrow and "A."

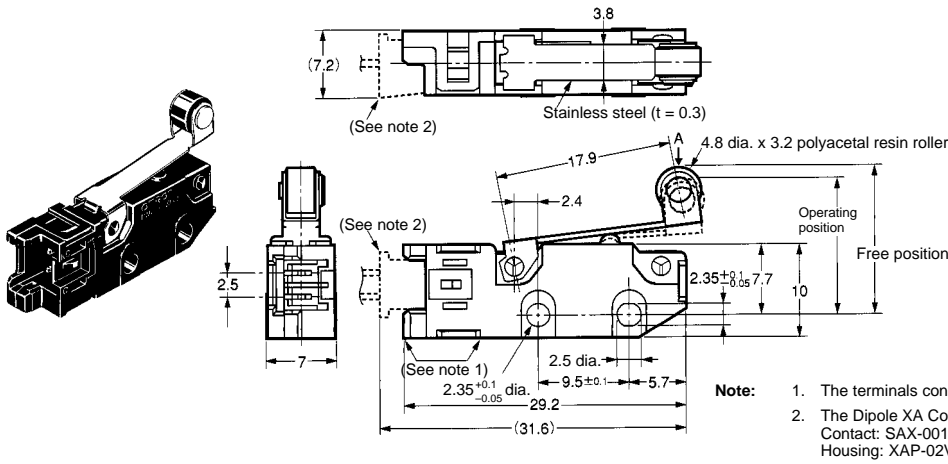

Operating characteristics	D3M-01L2, D3M-01L2-3
Max. operating force (OF)	1.00 N {102 gf}
Min. reset force (RF)	0.10 N {10 gf}
Min. overtravel (OT)	0.7 mm
Max. movement differential (MD)	0.6 mm
Max. free position (FP)	17.2 mm
Operating position (OP)	14.9±0.6 mm

Simulated Hinge Lever Models

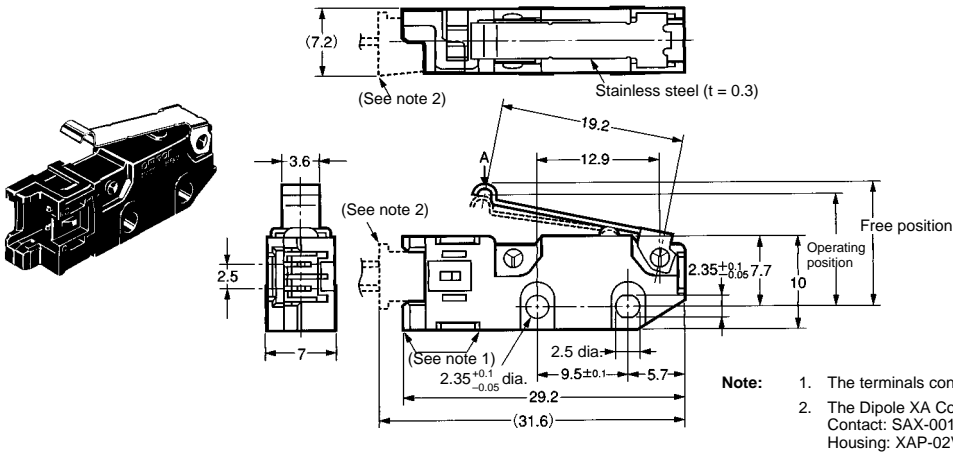

Operating characteristics	D3M-01K3, D3M-01K3-3
Max. operating force (OF)	0.50 N {51 gf}
Min. reset force (RF)	0.06 N {6 gf}
Min. overtravel (OT)	1.2 mm
Max. movement differential (MD)	0.8 mm
Max. free position (FP)	16.2 mm
Operating position (OP)	12.2±0.8 mm

Note: 1. A tolerance of ±0.4 mm applies to all the above dimensions unless otherwise specified.
2. The operating characteristics apply on condition that each actuator is moved in the direction indicated by the arrow and "A."

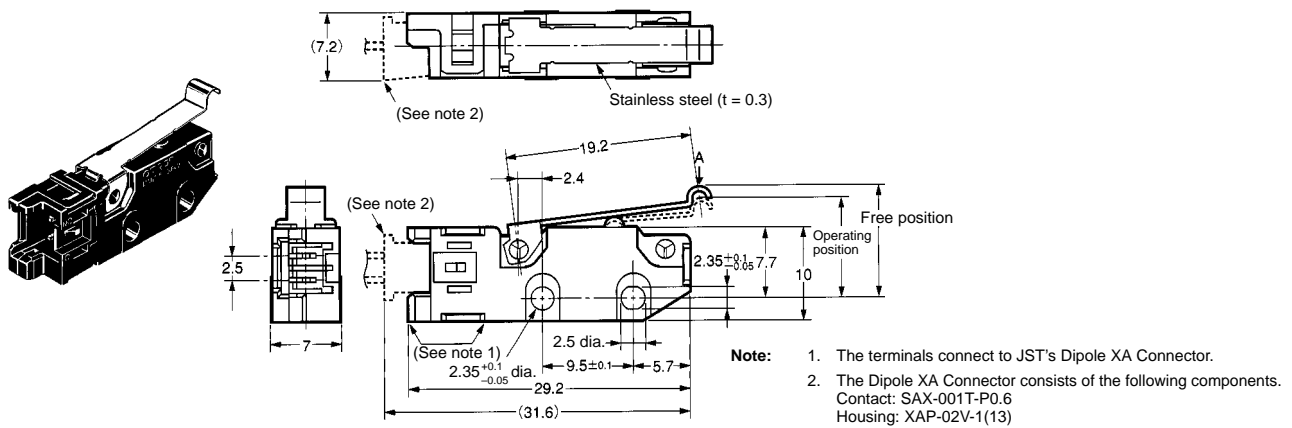

Operating characteristics	D3M-01L3, D3M-01L3-3
Max. operating force (OF)	1.00 N {102 gf}
Min. reset force (RF)	0.10 N {10 gf}
Min. overtravel (OT)	0.7 mm
Max. movement differential (MD)	0.6 mm
Max. free position (FP)	13.6 mm
Operating position (OP)	11.3±0.6 mm

- Note:**
1. A tolerance of ± 0.4 mm applies to all the above dimensions unless otherwise specified.
 2. The operating characteristics apply on condition that each actuator is moved in the direction indicated by the arrow and "A."

Precautions

■ Correct Use

Mounting

Be sure to turn OFF the D3M before mounting, dismounting, wiring, or servicing, otherwise an electric shock or a fire may result.

Make sure that the surface to which the D3M is mounted is flat. If the surface is not flat, the housing may distort and the D3M may malfunction, or the housing may crack.

Operating Stroke

Make sure that the dog is separated from the actuator when the actuator is in the free position and that the actuator is pressed appropriately when the D3M is actuated. The actuator must not be pressed excessively to reach the maximum overtravel position, otherwise the D3M may be damaged.

Make sure the actuator is pressed in the direction where the D3M is actuated.

Minute Load

If the load causes inrush current, even though the D3M is in operation within the permissible operating range, the life of the D3M may be shortened. In this case, insert a contact protection circuit.

The minimum applicable load is on the basis of level N, that is, a reliable rate of 60% ($\lambda 60$), in accordance with JIS C5003.

This rate ($\lambda 60 = 0.5 \times 10^{-6}$ /operations) means that the D3M is expected to have operational failure at least once per 2,000,000 operations.

Wiring

The terminals connect to JST's Dipole XA Connector.

The Dipole XA Connector consists of the following components.

Contact: SAX-001T-P0.6

Housing: XAP-02V-1

OMRON does not sell the Dipole XA Connector. Contact the following.

J.S.T. Manufacturing Co., Ltd. (Japan)

Tel: (81)45-543-1271

Fax: (81)45-544-1503

J.S.T. (U.K.) Ltd. (United Kingdom)

Tel: (44)1986-874131

Fax: (44)1986-874276

J.S.T. Corporation (U.S.A.)

Tel: (1)847-473-1957

Fax: (1)847-473-0144

J.S.T. (H.K.) Co. Ltd. (Hong Kong)

Tel: (852)24137979

Fax: (852)2411193



Caution

The voltage and current applied to the D3M when it is turned ON, turned OFF, and in operation must be within the rated ranges, otherwise the life of the D3M may be shortened. Furthermore, the D3M may radiate heat and burn.

ALL DIMENSIONS SHOWN ARE IN MILLIMETERS.

To convert millimeters into inches, multiply by 0.03937. To convert grams into ounces, multiply by 0.03527.

Cat. No. B100-E1-1 **In the interest of product improvement, specifications are subject to change without notice.**

OMRON Corporation

C&C Components Division H.Q.

Mechanical-Components Division

28th Fl., Crystal Tower Bldg.

1-2-27, Shiromi, Chuo-ku,

Osaka 540-6028 Japan

Phone: (81)6-949-6017 Fax: (81)6-949-6134

Printed in Japan

0198-1M (0198) a