





DPDT Basic Switch for Two Independent Circuit Control

- Incorporates two completely independent built-in switches.
- Ideal for switching the circuits operating on two different voltages, and for controlling two independent circuits.
- Interchangeable with OMRON Z Basic Switches, as both switches are identical in mounting hole dimensions, mounting pitch and pin plunger position.



Ordering Information

Actuator	OT	Solder terminal	Screw terminal
Pin plunger 	0.13 mm min.	DZ-10G-1A	DZ-10G-1B
Hinge lever 	1.6 mm min.	DZ-10GW-1A	DZ-10GW-1B
	0.4 mm min.	DZ-10GV-1A	DZ-10GV-1B
Short hinge roller lever 	0.9 mm min.	DZ-10GW22-1A	DZ-10GW22-1B
	0.13 mm min.	DZ-10GV22-1A	DZ-10GV22-1B
Hinge roller lever 	1.2 mm min.	DZ-10GW2-1A	DZ-10GW2-1B
	0.26 mm min.	DZ-10GV2-1A	DZ-10GV2-1B

Specifications

■ Ratings

Rated voltage	Non-inductive load				Inductive load				Inrush current	
	Resistive load		Lamp load		Inductive load		Motor load		NC	NO
	NC	NO	NC	NO	NC	NO	NC	NO		
125 VAC	10 A		2 A	1 A	6 A		3 A	1.5 A	30 A max.	15 A max.
250 VAC	10 A		1.5 A	0.7 A	4 A		2 A	1 A		
8 VDC	10 A		3 A	1.5 A	6 A		5 A	2.5 A		
14 VDC	10 A		3 A	1.5 A	6 A		5 A	2.5 A		
30 VDC	10 A		3 A	1.5 A	4 A		3 A	1.5 A		
125 VAC	0.5 A		0.5 A		0.05 A		0.05 A			
250 VDC	0.25 A		0.25 A		0.03 A		0.03 A			

- Note:**
1. Inductive load has a power factor of 0.4 min. (AC) and a time constant of 7 ms max. (DC).
 2. Lamp load has an inrush current of 10 times the steady-state current.
 3. Motor load has an inrush current of 6 times the steady-state current.

Contact Form

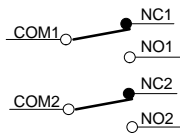

■ Characteristics

Operating speed	0.1 mm to 1 m/s (at pin plunger)
Operating frequency	Mechanical: 240 operations/min Electrical: 20 operations/min
Insulation resistance	100 MΩ min. (at 500 VDC)
Contact resistance	15 mΩ max. (initial value)
Dielectric strength	1,000 VAC, 50/60 Hz for 1 min between non-continuous terminals 1,500 VAC, 50/60 Hz for 1 min between current-carrying metal parts and non-current-carrying metal part, and between current-carrying metal part and ground and between switches
Vibration resistance	Malfunction: 10 to 55 Hz, 1.5-mm double amplitude
Shock resistance	Destruction: 1,000 m/s ² {approx. 100G} max. Malfunction: 300 m/s ² {approx. 30G} max.
Life expectancy	Mechanical: 1,000,000 operations min. Electrical: 500,000 operations min.
Ambient temperature	Operating: -25°C to 80°C (with no icing)
Ambient humidity	Operating: 35% to 85% max.
Weight	Approx. 30 to 50 g

■ Approved Standards

UL508 (File No. E41515)/CSA C22.2 No. 55 (File No. LR21642)

- DZ-10G:10 A, 125 VAC
- 10 A, 250 VAC
- 2 A, 480 VAC
- 1/2 A, 125 VDC
- 1/4 A, 250 VDC
- 1/8 HP 125 VAC
- 1/4 HP 250 VAC

Engineering Data

Mechanical Life Expectancy (Pin Plunger)

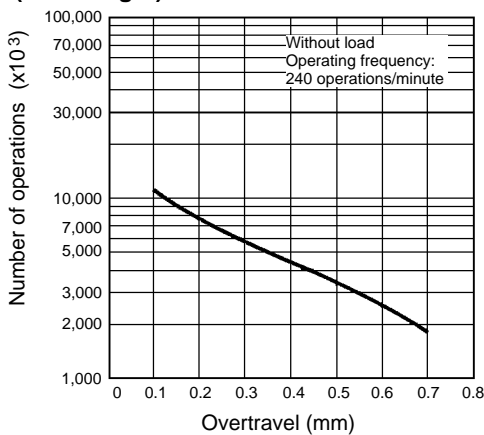

Electrical Life Expectancy (Pin Plunger)

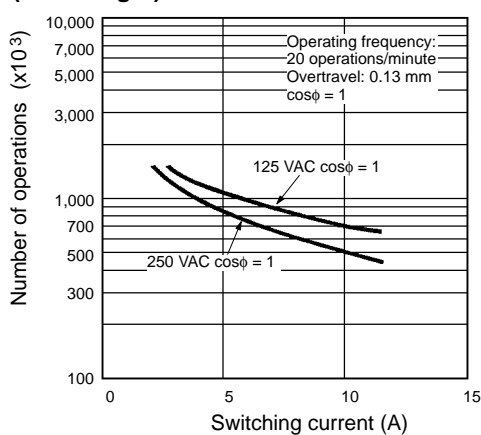

Dimensions

■ Terminals

Solder Terminals (-1A)

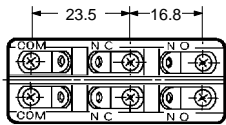

Screw Terminals (-1B)

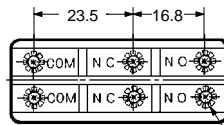

Six M3 pan head screws (with toothed washer)

■ Dimensions and Operating Characteristics

- Note:**
1. All units are in millimeters unless otherwise indicated.
 2. Unless otherwise specified, a tolerance of ± 0.4 mm applies to all dimensions.
 3. The solder terminal model has a suffix “-1A” in its model number and its omitted dimensions are the same as the corresponding dimensions of the pin plunger model.

Pin Plunger

DZ-10G-1B

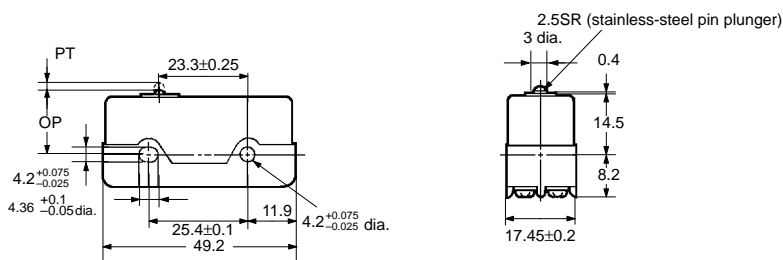

Model	DZ-10G-1B
OF max.	5.59 N {570 gf}
RF min.	0.55 N {57 gf}
PT max.	1.7 mm
OT min.	0.13 mm
MD max.	0.4 mm
OP	15.6±0.4 mm

Hinge Lever

DZ-10GW-1B

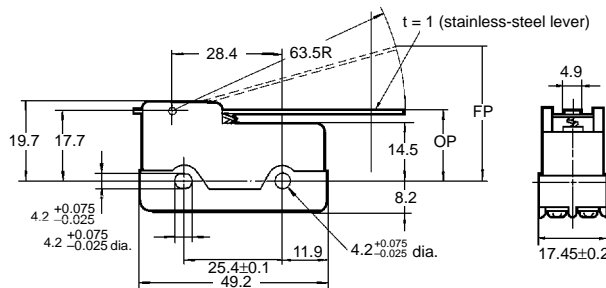
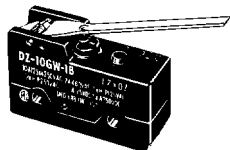

Model	DZ-10GW-1B
OF max.	1.67 N {170 gf}
RF min.	0.27 N {28 gf}
OT min.	1.6 mm
MD max.	4 mm
FP max.	46.3 mm
OP	21.8±1 mm

DZ-10GV-1B

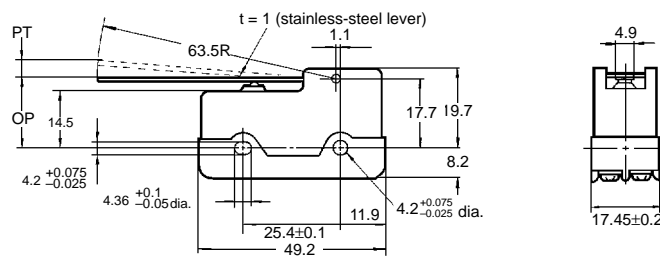
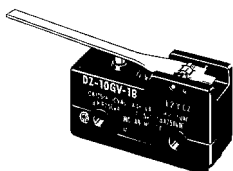

Model	DZ-10GV-1B
OF max.	1.96 N {200 gf}
RF min.	0.13 N {14 gf}
PT max.	6 mm
OT min.	0.4 mm
MD max.	1.7 mm
OP	18.3±1 mm

Short Hinge Roller Lever

DZ-10GW22-1B

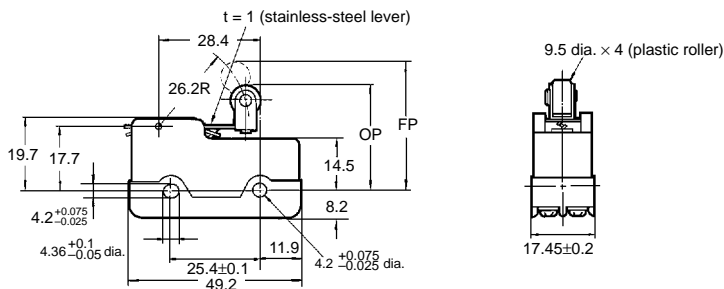

Model	DZ-10GW22-1B
OF max.	3.92 N {400 gf}
RF min.	0.83 N {85 gf}
OT min.	0.9 mm
MD max.	2.4 mm
FP max.	39.7 mm
OP	30.2±0.8 mm

DZ-10GV22-1B

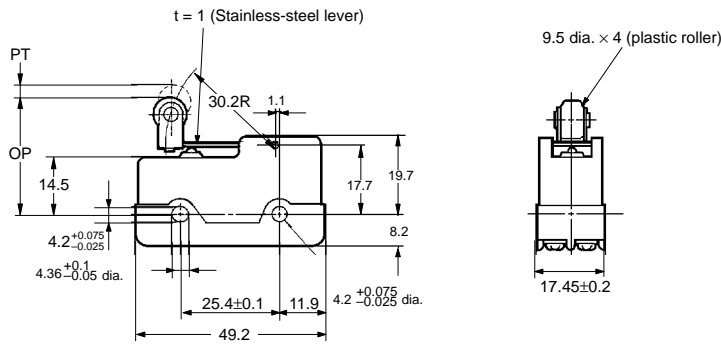

Model	DZ-10GV22-1B
OF max.	4.22 N {430 gf}
RF min.	0.41 N {42 gf}
PT max.	3 mm
OT min.	0.13 mm
MD max.	0.6 mm
OP	29.4±0.8 mm

Hinge Roller Lever

DZ-10GW2-1B

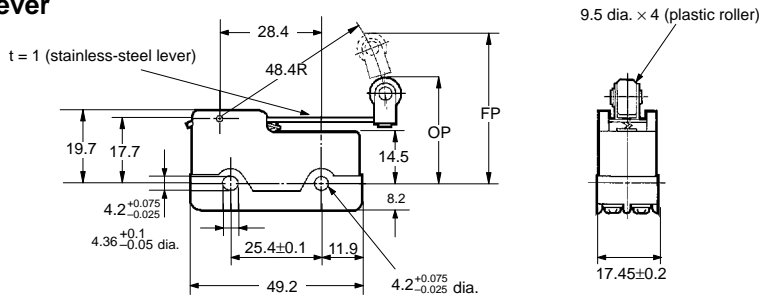
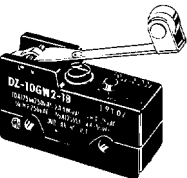

Model	DZ-10GW2-1B
OF max.	2.09 N {213 gf}
RF min.	0.41 N {42 gf}
OT min.	1.2 mm
MD max.	3.3 mm
FP max.	47.6 mm
OP	31.8±0.8 mm

DZ-10GV2-1B

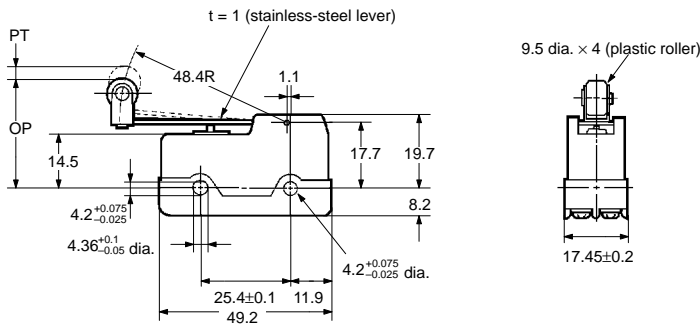
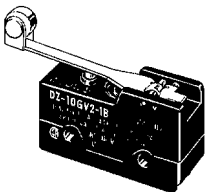

Model	DZ-10GV2-1B
OF max.	2.65 N {270 gf}
RF min.	0.33 N {34 gf}
PT max.	4 mm
OT min.	0.26 mm
MD max.	1.1 mm
OP	29.4±0.8 mm

Precautions

Terminal Connection

When soldering lead wires to the Switch, make sure that the capacity of the soldering iron is 60 W maximum. Do not take more than 5 s to solder any part of the Switch. Improper soldering may cause abnormal heat radiation from the Switch and the Switch may burn.

The characteristics of the Switch will deteriorate if a soldering iron with a capacity of more than 60 W is applied to any part of the Switch for 6 s or more.

Operation

Make sure that the switching frequency or speed is within the specified range.

1. If the switching speed is extremely slow, the contact may not be switched smoothly, which may result in a contact failure or contact welding.
2. If the switching speed is extremely fast, switching shock may damage the Switch soon. If the switching frequency is too high, the contact may not catch up with the speed.

The rated permissible switching speed and frequency indicate the switching reliability of the Switch.

The life of a Switch is determined at the specified switching speed. The life varies with the switching speed and frequency even when

they are within the permissible ranges. In order to determine the life of a Switch model to be applied to a particular use, it is best to conduct an appropriate life expectancy test on some samples of the model under actual conditions.

Make sure that the actuator travel does not exceed the permissible OT position. The operating stroke must be set to 70% to 100% of the rated OT.

■ Correct Use

Mounting

Use M4 screws with flat washers and spring washers to mount the Switch. Tighten each mounting screw securely to a torque of 1.18 to 1.47 N • m {12 to 15 kgf • cm}.

Mounting Dimensions

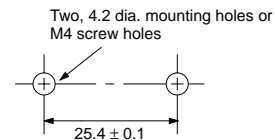

ALL DIMENSIONS SHOWN ARE IN MILLIMETERS.

To convert millimeters into inches, multiply by 0.03937. To convert grams into ounces, multiply by 0.03527.