

Best-selling Basic Switch Boasting High Precision and Wide Variety

- A large switching capacity of 15 A with high repeat accuracy.
- A wide range of variations in contact form for your selection: basic, split-contact, maintained-contact, and adjustable contact gap types.
- A series of standard models for minute loads is available.
- A series of molded terminal-type models incorporating safety terminal protective cover is available.



Ordering Information

■ Configuration

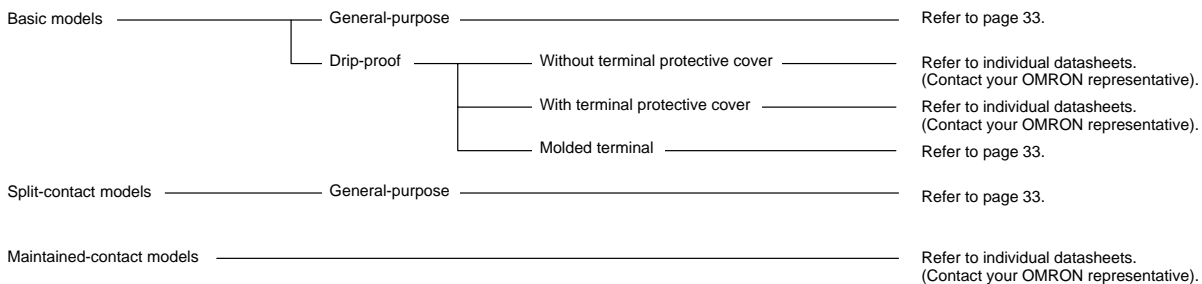

Basic Models

General-purpose

A variety of actuators is available for a wide range of application. The contact mechanism of models for minute loads is a crossbar type with gold-alloy contacts, which ensures highly reliable operations for minute loads.

Contact Gap:

- H: 0.25 mm (high-sensitivity, microvoltage current load)
- G: 0.5 mm (standard)
- E: 1.8 mm (high-capacity)
- F: 1.0 mm (split-contact models)

Contact Form (SPDT)

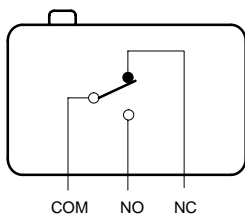

Note: The Z-15GM is a reversible model and the NO and NC positions are reversed.

Drip-proof Construction

Without Terminal Protective Cover

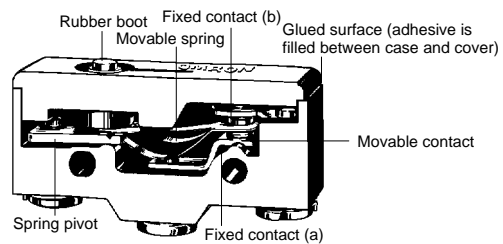

With Terminal Protective Cover

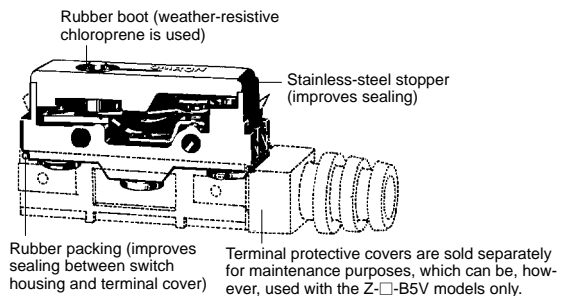

Split-contact Models

This type is identical in construction to the general-purpose basic switch except that it has two pairs of simultaneous acting contacts by splitting moving contacts.

Since the moving contacts are connected to a common terminal, either parallel or series connection is possible.

Highly reliable minute load switching is ensured if the model is used as a twin-contact switch.

Contact Form (Split-contact)

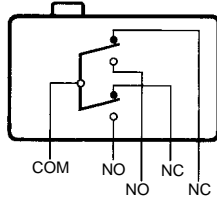

Connection Example

Series Connection

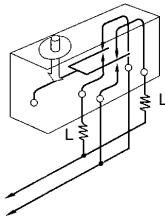

Parallel Connection

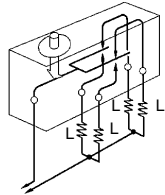

Model Number Legend

Z-□□□□-□
1 2 3 4 5

1. Ratings

01: 0.1 A (for micro load)
15: 15 A

2. Contact Gap

H: 0.25 mm (high-sensitivity, micro load)
G: 0.5 mm (standard)
E: 1.8 mm (high-capacity)

3. Actuator

None: Pin plunger
S: Slim spring plunger
D: Short spring plunger
K: Spring plunger (medium OP)
K3: Spring plunger (high OP)
Q3: Panel mount plunger (low OP)
Q: Panel mount plunger (medium OP)
Q8: Panel mount plunger (high OP)
Q22: Panel mount roller plunger
Q21: Panel mount cross roller plunger
L: Leaf spring (high OF)
L2: Roller leaf spring
W21: Short hinge lever
W: Hinge lever (low OF)
W3: Hinge lever (medium OF)
W32: Hinge lever (high OF)
W4: Low-force hinge lever
W44: Long hinge lever
W78: Low-force wire hinge lever (low OF)

Maintained-contact Models

The maintained-contact type has a reset button at the bottom of the switch case, in addition to the pushbutton (plunger) located on the opposite side of the reset button. Use these buttons alternately.

Since the Switch has greater pretravel than overtravel, it is suitable for use in reversible control circuits, manual reset circuits, safety limit circuits, and other circuits which are not preferable for automatic resetting. (For further details, refer to individual datasheets.)

Contact Form (Maintained-contact)

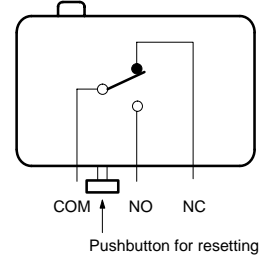

Model Number Legend

Z-□□□□-□
1 2 3 4 5

1. Ratings

01: 0.1 A (for micro load)
15: 15 A

2. Contact Gap

H: 0.25 mm (high-sensitivity, micro load)
G: 0.5 mm (standard)
E: 1.8 mm (high-capacity)

3. Actuator

None: Pin plunger
S: Slim spring plunger
D: Short spring plunger
K: Spring plunger (medium OP)
K3: Spring plunger (high OP)
Q3: Panel mount plunger (low OP)
Q: Panel mount plunger (medium OP)
Q8: Panel mount plunger (high OP)
Q22: Panel mount roller plunger
Q21: Panel mount cross roller plunger
L: Leaf spring (high OF)
L2: Roller leaf spring
W21: Short hinge lever
W: Hinge lever (low OF)
W3: Hinge lever (medium OF)
W32: Hinge lever (high OF)
W4: Low-force hinge lever
W44: Long hinge lever
W78: Low-force wire hinge lever (low OF)

W52: Low-force wire hinge lever (high OF)

W22: Short hinge roller lever

W2: Hinge roller lever

W25: Hinge roller lever (large roller)

W49: Short hinge cross roller lever

W54: Hinge cross roller lever

W2277: Unidirectional short hinge roller lever (Low OF)

M: Reverse hinge lever

M22: Reverse short hinge roller lever

M2: Reverse hinge roller lever

NJ: Flexible rod (high OF)

NJS: Flexible rod (low OF)

4. Enclosure Ratings

None: General-purpose

55: Drip-proof

A55: Drip-proof (including the terminals)

5. Terminals

None: Solder terminal

B: Screw terminal (with toothed washer)

B5V: Screw terminal with terminal cover (for Z-15G□A55 only)

Note: For combinations of models, refer to the following pages.

Z-10F□Y-B

1 2 3 4 5

1. **Ratings**
10: 10 A (Split-contact models)
2. **Contact Gap**
F: 1 mm (high-capacity)
3. **Actuator**
None: Pin plunger
S: Slim spring plunger
D: Short spring plunger
Q: Panel mount plunger
Q22: Panel mount roller plunger
W: Hinge lever
W22: Short hinge roller lever
W2: Hinge roller lever
M22: Reverse short hinge roller lever
4. **Construction**
Y: Split-contact models
5. **Terminals**
None: Solder terminal
B: Screw terminal (with toothed washer)

■ **Molded Terminals**

L/R Type

(The following illustration is the R type.)

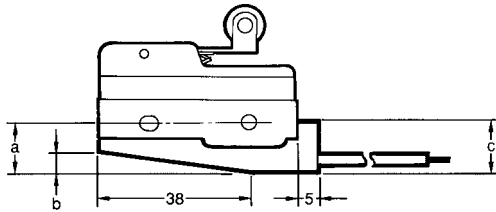

Lead wire	a	b	d
VSF	12	4	13
VCT	19	11	20

Z-□55-M□□□M

1 2 3 4

1. **Drip-proof Type**
2. **Lead Outlets**
None: VSF
19: VCT
3. **Directions of Lead Outlets**
Refer to the following diagrams.
4. **Length of Lead Outlets**
0.5: 0.5 m
1: 1 m
2: 2 m
3: 3 m

D Type

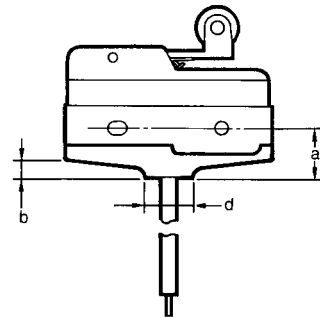

Lead wire	a	b	d
VSF	12	4	12
VCT	19	11	16

Lead Wire Specifications

Lead wire	Nominal cross-sectional area (mm ²)	Finished outer diameter (mm)	Connection to terminal	Length (m)
VSF (single-core, vinyl cord)	1.25	Approx. 3.1 dia.	Black: COM White: NO Red: NC	0.5, 1, 2, 3
VCT (vinyl-insulated cable)		Three-core: approx. 10.5 dia.		

Note: No models with molded terminals are approved by UL, CSA, or SEV.



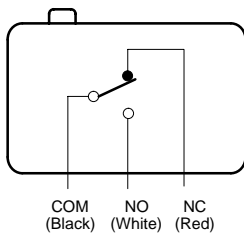













Contact Form



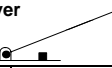
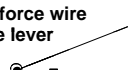

Note: With the reverse action model (Z-15GM), the positions of NO and NC terminals are reversed.

■ List of Models

Basic Models (General-purpose) & Split-contact Models

Actuator			Basic (general-purpose)			Split-contact
			Standard	High-sensitivity	High-capacity	
			G (0.5 mm)	H (0.25 mm)	E (1.8 mm)	F (1.0 mm)
Pin plunger 		Solder terminal	Z-15G	Z-15H	Z-15E	---
		Screw terminal	Z-15G-B	Z-15H-B	Z-15E-B	Z-10FY-B
Slim spring plunger 		Solder terminal	Z-15GS	Z-15HS	---	---
		Screw terminal	Z-15GS-B	Z-15HS-B	---	Z-10FSY-B
Short spring plunger 		Solder terminal	Z-15GD	Z-15HD	---	---
		Screw terminal	Z-15GD-B	Z-15HD-B	Z-15ED-B	Z-10FDY-B
Panel mount plunger 	Low OP	Solder terminal	Z-15GQ3	---	---	---
		Screw terminal	Z-15GQ3-B	---	---	---
	Medium OP	Solder terminal	Z-15GQ	Z-15HQ	Z-15EQ	---
		Screw terminal	Z-15GQ-B	Z-15HQ-B	Z-15EQ-B	Z-10FQY-B
	High OP	Solder terminal	Z-15GQ8	---	---	---
		Screw terminal	Z-15GQ8-B	---	---	---
Panel mount roller plunger 		Solder terminal	Z-15GQ22	Z-15HQ22	---	---
		Screw terminal	Z-15GQ22-B	Z-15HQ22-B	Z-15EQ22-B	Z-10FQ22Y-B
Panel mount cross roller plunger 		Solder terminal	Z-15GQ21	Z-15HQ21	---	---
		Screw terminal	Z-15GQ21-B	Z-15HQ21-B	Z-15EQ21-B	---
Leaf spring 		Solder terminal	Z-15GL	---	---	---
		Screw terminal	Z-15GL-B	---	---	---
Roller leaf spring 		Solder terminal	Z-15GL2	---	---	---
		Screw terminal	Z-15GL2-B	---	---	---
Short hinge lever 		Solder terminal	Z-15GW21	---	---	---
		Screw terminal	Z-15GW21-B	---	---	---
Hinge lever 	Low OF	Solder terminal	Z-15GW	Z-15HW	---	---
		Screw terminal	Z-15GW-B	Z-15HW-B	---	Z-10FWY-B
	Medium OF	Solder terminal	Z-15GW3	---	---	---
		Screw terminal	Z-15GW3-B	---	---	---
	High OF	Solder terminal	Z-15GW32	---	---	---
		Screw terminal	Z-15GW32-B	---	---	---
Low-force hinge lever 		Solder terminal	Z-15GW4	Z-15HW24	---	---
		Screw terminal	Z-15GW4-B	Z-15HW24-B	---	---
Low-force wire hinge lever 	Low OF	Solder terminal	---	Z-15HW78	---	---
		Screw terminal	---	Z-15HW78-B	---	---
	High OF	Solder terminal	---	Z-15HW52	---	---
		Screw terminal	---	Z-15HW52-B	---	---
Short hinge roller lever 		Solder terminal	Z-15GW22	Z-15HW22	Z-15EW22	---
		Screw terminal	Z-15GW22-B	Z-15HW22-B	Z-15EW22-B	Z-10FW22Y-B
Short hinge cross roller lever 		Solder terminal	Z-15GW49	---	---	---
		Screw terminal	Z-15GW49-B	---	---	---
Hinge roller lever 	Parallel	Solder terminal	Z-15GW2	Z-15HW2	---	---
		Screw terminal	Z-15GW2-B	Z-15HW2-B	---	Z-10FW2Y-B
	Large roller	Solder terminal	Z-15GW25	---	---	---
		Screw terminal	Z-15GW25-B	---	---	---
Hinge cross roller lever 		Solder terminal	Z-15GW54	---	---	---
		Screw terminal	Z-15GW54-B	---	---	---
Unidirectional short hinge roller lever 		Solder terminal	Z-15GW2277	---	---	---
		Screw terminal	Z-15GW2277-B	---	---	---
Reverse hinge lever (see note) 		Solder terminal	Z-15GM	---	---	---
		Screw terminal	Z-15GM-B	---	---	---

Actuator	Basic (general-purpose)				Split-contact
	Standard	High-sensitivity	High-capacity		
	G (0.5 mm)	H (0.25 mm)	E (1.8 mm)	F (1.0 mm)	
Reverse short hinge roller lever (see note) 	Solder terminal	Z-15GM22	---	---	---
	Screw terminal	Z-15GM22-B			Z-10FM22Y-B
Reverse hinge roller lever (see note) 	Solder terminal	Z-15GM2	---	---	---
	Screw terminal	Z-15GM2-B			







Note: The pin plungers of reverse-type models are continuously pressed by the actuator levers with compression coil springs and the pin plungers are freed by operating the levers. Reverse-type models are highly vibration- and shock-resistant because the pin plungers are normally pressed.













Minimum Order Lot

The following models are available at the minimum order lot specified below. Orders must be placed per lot.

Actuator	Standard	High-sensitivity	Minimum order lot (pcs)
	G (0.5 mm)	H (0.25 mm)	
Short spring plunger	Z-15GD-B	---	10
Panel mount plunger	Z-15GQ	---	
	Z-15GQ-B		
	Z-15GQ8-B		
Panel mount roller plunger	Z-15GQ22	---	
	Z-15GQ22-B		
Panel mount cross roller plunger	Z-15GQ21-B	---	
Short hinge lever	Z-15GW21-B	---	
Hinge lever	Z-15GW	---	
	Z-15GW-B		
Low-force hinge lever	Z-15GW4-B	Z-15HW24-B	
Low-force hinge wire lever	---	Z-15HW78-B	
Short hinge roller lever	Z-15GW22	---	
	Z-15GW22-B		
Hinge roller lever	Z-15GW2	---	
	Z-15GW2-B		
Reverse short hinge roller lever	Z-15GM22-B	---	
Reverse hinge roller lever	Z-15GM2-B	---	

Basic Models (Drip-proof Models)

Actuator	Basic model (drip-proof)				
	Standard		Micro load		
	G (0.5 mm)		H (0.25 mm)		
	Without drip-proof terminal protective cover	With drip-proof terminal protective cover	Without drip-proof terminal protective cover	With drip-proof terminal protective cover	
Pin plunger 	Solder terminal	Z-15G55	---	Z-01H55	
	Screw terminal	Z-15G55-B	Z-15GA55-B5V	Z-01H55-B	
Short spring plunger 	Solder terminal	Z-15GD55	---	Z-01HD55	
	Screw terminal	Z-15GD55-B		Z-01HD55-B	
Spring plunger 	Medium OP	Solder terminal	Z-15GK55	---	
		Screw terminal	Z-15GK55-B		
	High OP	Solder terminal	Z-15GK355	---	---
		Screw terminal	Z-15GK355-B	Z-15GK3A55-B5V	
Panel mount plunger 	Medium OP	Solder terminal	Z-15GQ55	---	
		Screw terminal	Z-15GQ55-B	Z-15GQA55-B5V	
Panel mount roller plunger 	Solder terminal	Z-15GQ2255	---	---	
	Screw terminal	Z-15GQ2255-B	Z-15GQ22A55-B5V		
Panel mount cross roller plunger 	Solder terminal	---	---	---	
	Screw terminal	Z-15GQ2155-B	Z-15GQ21A55-B5V		

Actuator	Basic model (drip-proof)			
	Standard		Micro load	
	G (0.5 mm)		H (0.25 mm)	
	Without drip-proof terminal protective cover	With drip-proof terminal protective cover	Without drip-proof terminal protective cover	With drip-proof terminal protective cover
Leaf spring 	Solder terminal	Z-15GL55	---	---
	Screw terminal	Z-15GL55-B	---	---
Roller leaf spring 	Solder terminal	Z-15GL255	---	---
	Screw terminal	Z-15GL255-B	---	---
Short hinge lever 	Solder terminal	Z-15GW2155	---	---
	Screw terminal	Z-15GW2155-B	---	---
Long hinge lever 	Solder terminal	Z-15GW4455	---	---
	Screw terminal	Z-15GW4455-B	Z-15GW44A55-B5V	---
Hinge lever 	Solder terminal	Z-15GW55	---	---
	Screw terminal	Z-15GW55-B	Z-15GWA55-B5V	---
Short hinge roller lever 	Solder terminal	Z-15GW2255	---	Z-01HW2255
	Screw terminal	Z-15GW2255-B	Z-15GW22A55-B5V	Z-01HW2255-B
Hinge roller lever 	Parallel	Solder terminal	Z-15GW255	---
		Screw terminal	Z-15GW255-B	Z-15GW2A55-B5V
Unidirectional short hinge roller lever 	Solder terminal	Z-15GW227755	---	---
	Screw terminal	Z-15GW227755-B	Z-15GW2277A55-B5V	---
Reverse hinge lever (see note 1) 	Solder terminal	Z-15GM55	---	---
	Screw terminal	Z-15GM55-B	---	---
Reverse short hinge roller lever (see note 1) 	Solder terminal	Z-15GM2255	---	---
	Screw terminal	Z-15GM2255-B	---	---
Reverse hinge roller lever (see note 1) 	Solder terminal	Z-15GM255	---	---
	Screw terminal	Z-15GM255-B	---	---
Flexible rod (coil spring) (see note 2) 	Solder terminal	Z-15GNJ55	---	---
	Screw terminal	Z-15GNJ55-B	---	---



Note: 1. The pin plungers of reverse-type models are continuously pressed by the actuator levers with compression coil springs and the pin plungers are freed by operating the levers.

2. The tip is made of resin.

Basic Models (Drip-proof High-sensitivity Models)

Actuator	High-sensitivity	
	H (0.25 mm)	
Flexible rod (steel wire) 	Solder terminal	Z-15HNJS55
	Screw terminal	Z-15HNJS55-B

Basic Models (Maintained-contact Models)

Actuator	Maintained-contact model
Pin plunger 	Z-15ER
Slim spring plunger 	Z-15ESR
Hinge lever 	Z-15EWR

Specifications

■ Ratings

Z-15 (Except Micro Load and Flexible Rod Models)

Item Model	Rated voltage	Non-inductive load				Inductive load			
		Resistive load		Lamp load		Inductive load		Motor load	
		NC	NO	NC	NO	NC	NO	NC	NO
G, H, E	125 VAC	15 (10) A (see note)		3 A	1.5 A	15 (10) A (see note)		5 A	2.5 A
	250 VAC	15 (10) A (see note)		2.5 A	1.25 A	15 (10) A (see note)		3 A	1.5 A
	500 VAC	10 A		1.5 A	0.75 A	6 A		1.5 A	0.75 A
G	8 VDC	15 A		3 A	1.5 A	15 A		5 A	2.5 A
	14 VDC	15 A		3 A	1.5 A	10 A		5 A	2.5 A
	30 VDC	6 A		3 A	1.5 A	5 A		5 A	2.5 A
	125 VDC	0.5 A		0.5 A	0.5 A	0.05 A		0.05 A	0.05 A
	250 VDC	0.25 A		0.25 A	0.25 A	0.03 A		0.03 A	0.03 A
H	8 VDC	15 A		3 A	1.5 A	15 A		5 A	2.5 A
	14 VDC	15 A		3 A	1.5 A	10 A		5 A	2.5 A
	30 VDC	2 A		2 A	1.4 A	1 A		1 A	1 A
	125 VDC	0.4 A		0.4 A	0.4 A	0.03 A		0.03 A	0.03 A
	250 VDC	0.2 A		0.2 A	0.2 A	0.02 A		0.02 A	0.02 A
E	8 VDC	15 A		3 A	1.5 A	15 A		5 A	2.5 A
	14 VDC	15 A		3 A	1.5 A	15 A		5 A	2.5 A
	30 VDC	15 A		3 A	1.5 A	10 A		5 A	2.5 A
	125 VDC	0.75 A		0.75 A	0.75 A	0.4 A		0.4 A	0.4 A
	250 VDC	0.3 A		0.3 A	0.3 A	0.2 A		0.2 A	0.2 A

Note: Figures in parentheses are for the Z-15H2, Z-15HW52, and Z-15HW78(-B) models, the AC ratings of these models are 125 and 250 V only.

Z-15 (Flexible Rod Models)

Rated voltage	Non-inductive load				Inductive load			
	Resistive load		Lamp load		Inductive load		Motor load	
	NC	NO	NC	NO	NC	NO	NC	NO
125 VAC	15 A		2 A	1 A	7 A		2.5 A	2 A
250 VAC	15 A		1 A	0.5 A	5 A		1.5 A	1 A
8 VDC	15 A		2 A	1 A	7 A		3 A	1.5 A
14 VDC	15 A		2 A	1 A	7 A		3 A	1.5 A
30 VDC	2 A		2 A	1 A	1 A		1 A	0.5 A
125 VDC	0.4 A		0.4 A	0.4 A	0.03 A		0.03 A	0.03 A
250 VDC	0.2 A		0.2 A	0.2 A	0.02 A		0.02 A	0.02 A

Minimum Order Lot

The following models are available at the minimum order lot specified below. Orders must be placed per lot.

Actuator	Standard		High-sensitivity	Minimum order lot
	G (0.5 mm)		H (0.25 mm)	
Short spring plunger	Z-15GD55-B	---	---	10
Spring plunger	Z-15GK55-B	---	---	
Hinge lever	Z-15GW4455-B Z-15GW55 Z-15GW55-B	---	---	
Short hinge roller lever	Z-15GW2255 Z-15GW2255-B	---	---	
Hinge roller lever	Z-15GW255-B	---	---	
Flexible rod (coil spring)	Z-15GNJ55-B	---	---	
Flexible rod (steel wire)	---	---	Z-15HNJS55-B	

Z-01H

Rated voltage	Resistive load	
	NC	NO
125 VAC	0.1 A	
8 VDC	0.1 A	
14 VDC	0.1 A	
30 VDC	0.1 A	

Z-10F

Model	Rated voltage	Non-inductive load				Inductive load			
		Resistive load		Lamp load		Inductive load		Motor load	
		NC	NO	NC	NO	NC	NO	NC	NO
Series connection	125 VAC	10 A		4 A	2 A	6 A		5 A	2.5 A
	250 VAC	10 A		2.5 A	1.5 A	6 A		3 A	1.5 A
	30 VDC	10 A		4 A	2 A	6 A		6 A	3 A
	125 VDC	1 A		1 A	1 A	0.1 A		0.1 A	0.1 A
	250 VDC	0.6 A		0.6 A	0.6 A	0.05 A		0.05 A	0.05 A
Parallel connection	125 VAC	6 A		3 A	1.5 A	4 A		4 A	2 A
	250 VAC	6 A		2.5 A	1.25 A	4 A		2 A	1 A
	30 VDC	6 A		4 A	2 A	4 A		6 A	3 A
	125 VDC	0.6 A		0.6 A	0.6 A	0.1 A		0.1 A	0.1 A
	250 VDC	0.3 A		0.3 A	0.3 A	0.05 A		0.05 A	0.05 A

- Note:**
- The above current ratings are the values of the steady-state current.
 - Inductive load has a power factor of 0.4 min. (AC) and a time constant of 7 ms max. (DC).
 - Lamp load has an inrush current of 10 times the steady-state current.
 - Motor load has an inrush current of 6 times the steady-state current.
 - The normally closed and normally open ratings of reverse hinge lever models are opposite to each other.
 - The AC ratings of molded terminals are 125 and 250 V only.
 - The ratings values apply under the following test conditions:
Ambient temperature: 20±2°C
Ambient humidity: 65±5%
Operating frequency: 20 operations/min

Use the Switch in the following operating range.

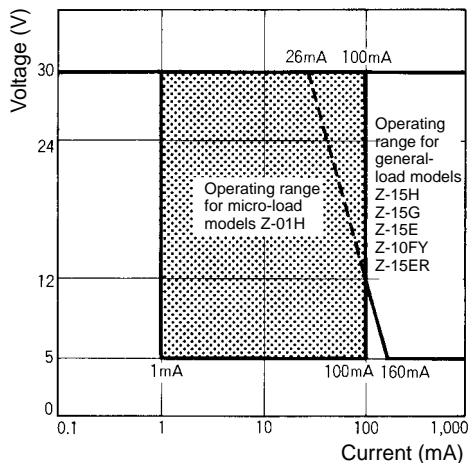

Item	Z-01H	Z-15□, Z-10FY
Minimum applicable load	1 mA at 5 VDC	160 mA at 5 VDC

■ Characteristics

Item	Basic (except micro load and flexible rod)/ maintained contact Z-15	Basic (micro load) Z-01H	Basic (flexible rod) Z-15	Split-contact Z-10F
Operating speed (see note)	0.01 mm to 1 m/s (see note 1)		1 mm to 1 m/s	0.1 mm to 1 m/s (see note 1)
Operating frequency	Mechanical: 240 operations/min Electrical: 20 operations/min		Mechanical: 120 operations/min Electrical: 20 operations/min	Mechanical: 240 operations/min Electrical: 20 operations/min
Insulation resistance	100 MΩ min. (at 500 VDC)			
Contact resistance	15 mΩ max. (initial value)	50 mΩ max. (initial value)	15 mΩ max. (initial value)	25 mΩ max. (initial value)
Dielectric strength	<u>Between contacts of same polarity</u> Contact gap G: 1,000 VAC, 50/60 Hz for 1 min Contact gap H: 600 VAC, 50/60 Hz for 1 min Contact gap E: 1,500 VAC, 50/60 Hz for 1 min <u>Between current-carrying metal parts and ground, and between each terminal and non-current-carrying metal parts</u> 2,000 VAC, 50/60 Hz for 1 min		<u>Between contacts of same polarity</u> Contact gap G: 1,000 VAC, 50/60 Hz for 1 min Contact gap H: 600 VAC, 50/60 Hz for 1 min <u>Between current-carrying metal parts and ground, and between each terminal and non-current-carrying metal parts</u> 2,000 VAC, 50/60 Hz for 1 min	
Vibration resistance	Malfunction: 10 to 55 Hz, 1.5-mm double amplitude (see note 5)		Malfunction: 10 to 20 Hz, 1.5-mm double amplitude (see note 5)	Malfunction: 10 to 55 Hz, 1.5-mm double amplitude (see note 5)
Shock resistance	<u>Destruction:</u> 1,000 m/s ² {approx. 100G} max. <u>Malfunction:</u> 300 m/s ² {approx. 30G} max. (see note 2, 5)		<u>Destruction:</u> 1,000 m/s ² {approx. 100G} max. <u>Malfunction:</u> 50 m/s ² {approx. 5G} max. (see note 5)	
Life expectancy	<u>Mechanical:</u> Contact gap G, H: 20,000,000 operations min. (see note 4) Contact gap E: 300,000 operations <u>Electrical:</u> Contact gap G, H: 500,000 operations min. Contact gap E: 100,000 operations min.		<u>Mechanical:</u> 1,000,000 operations min. <u>Electrical:</u> 100,000 operations min.	
Degree of protection	General-purpose: IP00 Drip-proof: IP62			
Degree of protection against electric shock	Class I			
Proof tracking index (PTI)	175			
Switch category	D (IEC335-1)			
Ambient temperature	Operating: General-purpose: -25°C to 80°C (with no icing) Drip-proof: -15°C to 80°C (with no icing)			
Ambient humidity	Operating: General-purpose: 85% max. Drip-proof: 95% max.			
Weight	Approx. 22 to 58 g		Approx. 42 to 48 g	Approx. 34 to 61 g

Note: 1. The values are for the plunger models. (For the lever models, the values are at the plunger section.) (Contract your OMRON representative for other models.)

2. The values are for the Z-15G pin plunger.
3. The values are for the Z-10FY-B.
4. The values are for the pin plunger. The life expectancy for models other than the pin plunger is 10,000,000 min.
5. Malfunction: 1 ms max.

■ Approved Standards

UL508 (File No. E41515)

CSA C22.2 No.55 (File No. LR21642)

Rated voltage	Z-15	Z-10F	Z-01H
125 VAC	15 A 1/8 HP	6 A 1/10 HP	0.1 A
250 VAC	15 A 1/4 HP	6 A 1/8 HP	---
480 VAC	15 A	6 A	---
30 VDC	---	---	0.1 A
125 VDC	0.5 A	0.6 A	---
250 VDC	0.25 A	0.3 A	---

EN (EN61058-1)

Rated voltage	Z-15H	Z-15G	Z-01H
250 VAC	15 A	15 A	---
125 VAC	---	---	0.1 A
30 VDC	---	---	0.1 A

Note: Consult with Omron about approved part numbers by standards.

■ Contact Specification

Item		Z-15	Z-01H	Z-10F
Contacts	Shape	Rivet	Single crossbar	Rivet
	Material	Silver alloy	Gold alloy	Silver alloy
Inrush current	NC	30 A max.	0.1 A max.	40 A max.
	NO	15 A max.	0.1 A max.	20 A max.

Engineering Data

Mechanical Life Expectancy

Z-15G

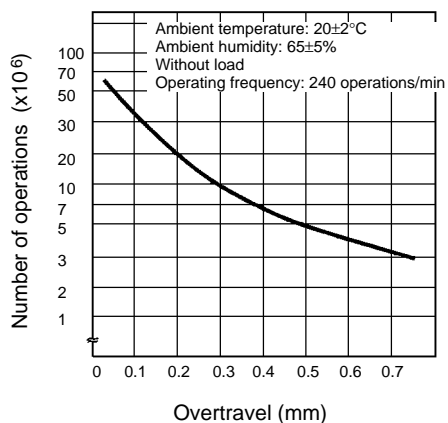

Electrical Life Expectancy

Z-15G

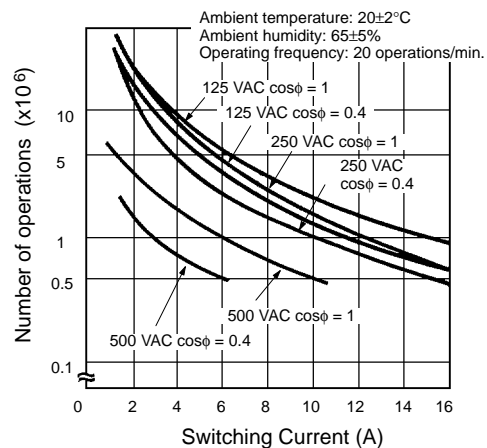

Dimensions

- Note:** 1. All units are in millimeters unless otherwise indicated.
 2. Unless otherwise specified, a tolerance of ± 0.4 mm applies to all dimensions.

■ Terminals

Basic (General-purpose) Models		Split-contact Models
<p>Screw Terminals (-B)</p> <p>Appropriate terminal screw tightening torque: 0.78 to 1.18 N • m {8 to 12 kgf • cm}.</p>	<p>Solder Terminal</p>	<p>Screw Terminals (Y-B)</p> <p>Appropriate terminal screw tightening torque: 0.49 to 0.78 N • m {5 to 8 kgf • cm}.</p>
<p>Note: With reverse action models (Z-15GM and Z-10FM), the positions of NO and NC terminals are reversed.</p>		

■ Dimensions and Operating Characteristics

Pin Plunger

Z-15G-B, Z-15E-B
 Z-15H-B, Z-01H-B
 Z-10FY-B

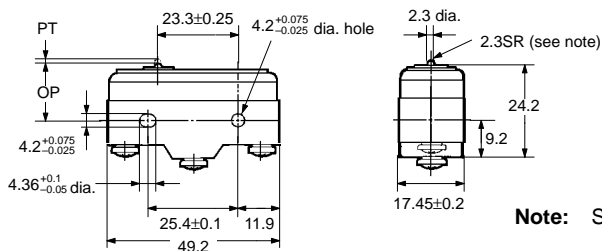

Note: Stainless-steel plunger

Model	Pin plunger				
	Z-15G-B	Z-15H-B	Z-15E-B	Z-01H-B	Z-10FY-B
OF	2.45 to 3.43 N {250 to 350 gf}	1.96 to 2.75 N {200 to 280 gf}	6.12 to 7.85 N {625 to 800 gf}	2.45 N {250 gf} max.	4.46 to 7.26 N {455 to 740 gf}
RF min.	1.12 N {114 gf}	1.12 N {114 gf}	1.12 N {114 gf}	0.78 N {80 gf}	1.12 N {114 gf}
PT max.	0.4 mm	0.3 mm	0.8 mm	0.5 mm	0.8 mm
OT min.	0.13 mm	0.13 mm	0.13 mm	0.13 mm	0.13 mm
MD max.	0.05 mm	0.025 mm	0.13 mm	0.04 mm	0.1 mm
OP	15.9±0.4 mm				

Slim Spring Plunger

Z-15GS-B, Z-15HS-B,
Z-01HS-B, Z-10FSY-B

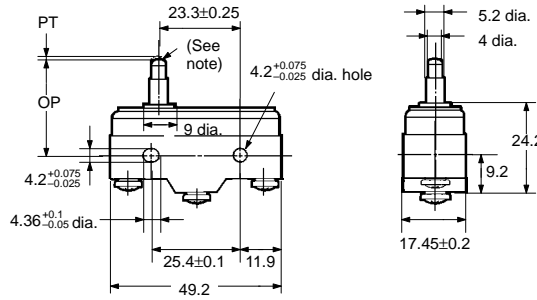
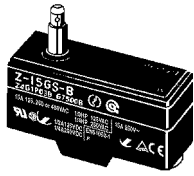

Note: Stainless-steel plunger (flat, 1R chamfered)

Model	Slim spring plunger			
	Z-15GS-B	Z-15HS-B	Z-01HS	Z-10FSY-B
OF	2.45 to 3.43 N {250 to 350 gf}	1.96 to 2.79 N {200 to 285 gf}	2.45 N {250 gf} max.	4.46 to 7.26 N {455 to 740 gf}
RF min.	1.12 N {114 gf}	1.12 N {114 gf}	0.78 N {80 gf}	1.12 N {114 gf}
PT max.	0.4 mm	0.3 mm	0.5 mm	0.8 mm
OT min.	1.6 mm	1.6 mm	1.6 mm	1.6 mm
MD max.	0.05 mm	0.025 mm	0.05 mm	0.1 mm
OP	28.2 ± 0.5 mm			

Short Spring Plunger

Z-15GD-B, Z-01HD-B
Z-15HD-B, Z-10FDY-B
Z-15ED-B

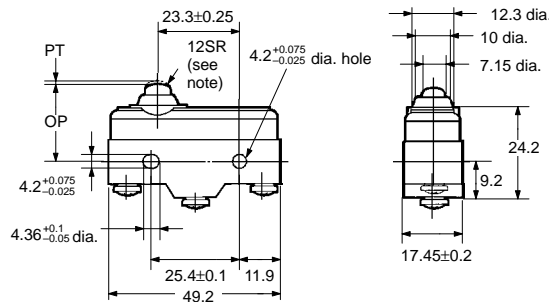
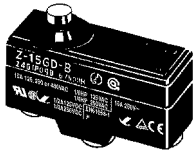

Note: Plated iron plunger

Model	Short spring plunger				
	Z-15GD-B	Z-15HD-B	Z-15ED-B	Z-01HD-B	Z-10FDY-B
OF	2.45 to 3.43 N {250 to 350 gf}	1.96 to 2.79 N {200 to 285 gf}	6.13 to 7.85 N {625 to 800 gf}	2.45 N {250 gf} max.	4.46 to 7.26 N {455 to 740 gf}
RF min.	1.12 N {114 gf}	1.12 N {114 gf}	1.12 N {114 gf}	0.78 N {80 gf}	1.12 N {114 gf}
PT max.	0.4 mm	0.3 mm	0.8 mm	0.5 mm	0.8 mm
OT min.	1.6 mm	1.6 mm	1.6 mm	1.6 mm	1.6 mm
MD max.	0.05 mm	0.025 mm	0.13 mm	0.05 mm	0.1 mm
OP	21.5 ± 0.5 mm				

Panel Mount Plunger

Z-15GQ-B, Z-01HQ-B
Z-15HQ-B, Z-10FQY-B
Z-15EQ-B

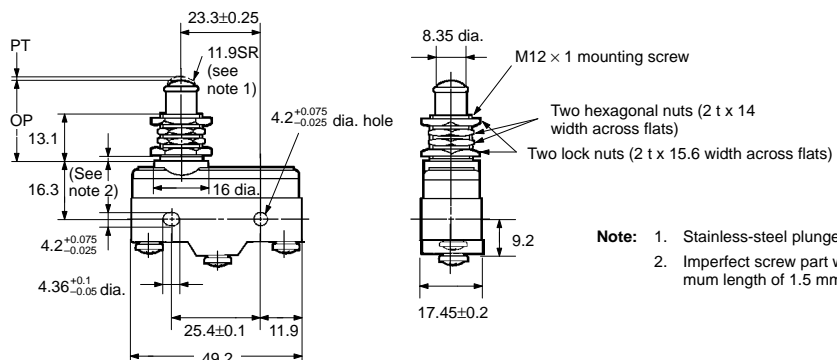
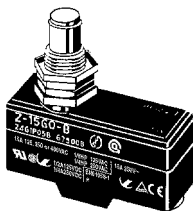

Note: 1. Stainless-steel plunger
2. Imperfect screw part with a maximum length of 1.5 mm.

Z-15GQ3-B

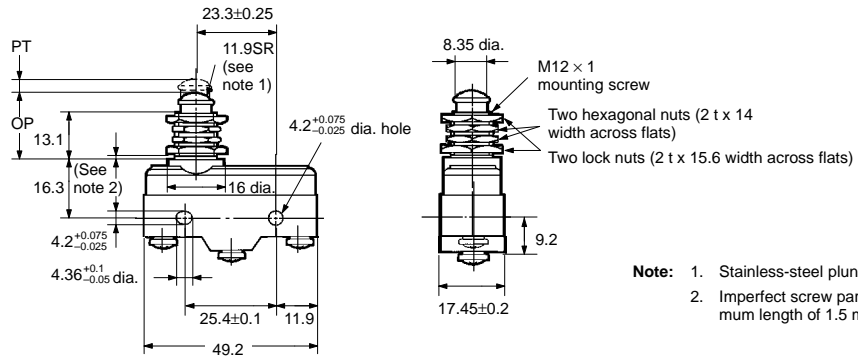
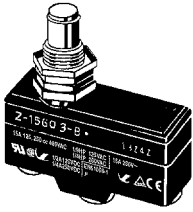

- Note:**
1. Stainless-steel plunger
 2. Imperfect screw part with a maximum length of 1.5 mm.

Z-15GQ8-B

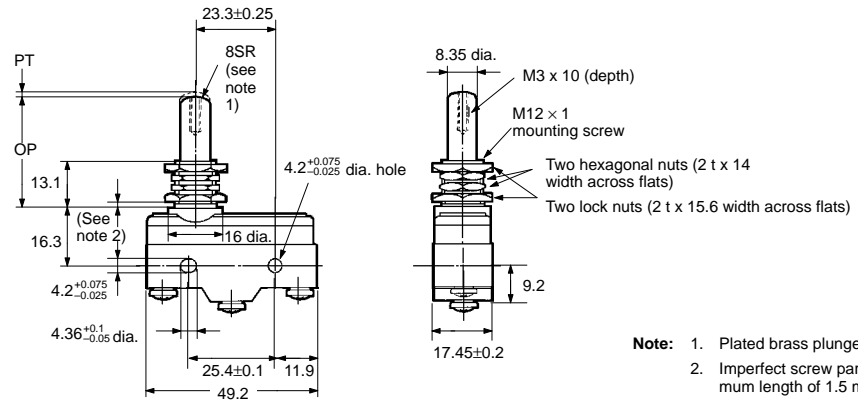
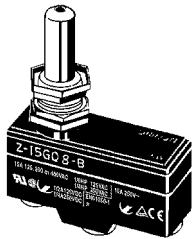

- Note:**
1. Plated brass plunger
 2. Imperfect screw part with a maximum length of 1.5 mm.

Model	Panel mount plunger							
	Z-15GQ-B	Z-15HQ-B	Z-15EQ-B	Z-01HQ-B	Z-10FQY-B	Z-15GQ3-B	Z-15GQ8-B	
OF	2.45 to 3.43 N {250 to 350 gf}	1.96 to 2.79 N {200 to 285 gf}	6.13 to 7.85 N {625 to 800 gf}	2.45 N {250 gf} max.	4.46 to 7.26 N {455 to 740 gf}	2.45 to 3.43 N {250 to 350 gf}	2.45 to 3.43 N {250 to 350 gf}	
RF min.	1.12 N {114 gf}	1.12 N {114 gf}	1.12 N {114 gf}	0.78 N {80 gf}	1.12 N {114 gf}	1.12 N {114 gf}	1.12 N {114 gf}	
PT max.	0.4 mm	0.3 mm	0.8 mm	0.5 mm	0.8 mm	4.2 mm	0.5 mm	
OT min.	5.5 mm	5.5 mm	5.5 mm	5.5 mm	5.5 mm	2.5 mm	5.5 mm	
MD max.	0.05 mm	0.025 mm	0.13 mm	0.05 mm	0.1 mm	2.2 mm	0.05 mm	
OP	21.8±0.8 mm					18.8±0.8 mm		32.5±1 mm

- Note:**
1. Do not use the M12 mounting screw and the case mounting hole at the same time, or excessive pulling force will be imposed on the Switch and the case and cover may be damaged.
 2. On the model Z-15GQ3-B, PT can be set to a value larger than that for the Z-15GQ.
 3. On the model Z-15GQ8-B, operating position can be adjusted by providing a screw in the plunger section. The M3 hole with a depth of 10 mm is a through hole. Take precautions so that no water or screw lock agent penetrates into the hole.

Panel Mount Roller Plunger

**Z-15GQ22-B, Z-15EQ22-B
Z-15HQ22-B, Z-10FQ22Y-B**

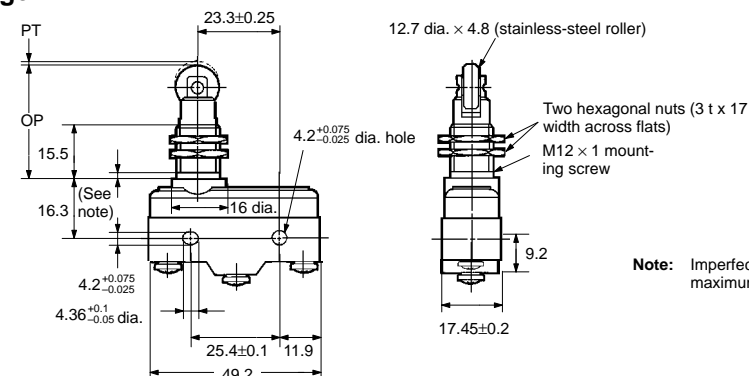
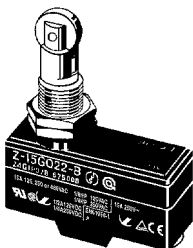

- Note:** Imperfect screw part with a maximum length of 1.5 mm.

Model	Panel mount roller plunger			
	Z-15GQ22-B	Z-15HQ22-B	Z-15EQ22-B	Z-10FQ22Y-B
OF	2.45 to 3.43 N {250 to 350 gf}	1.96 to 2.79 N {200 to 285 gf}	6.13 to 7.85 N {625 to 800 gf}	4.46 to 7.26 N {455 to 740 gf}
RF min.	1.12 N {114 gf}	1.12 N {114 gf}	1.12 N {114 gf}	1.12 N {114 gf}
PT max.	0.4 mm	0.3 mm	0.8 mm	1 mm
OT min.	3.58 mm	3.58 mm	3.58 mm	3.55 mm
MD max.	0.05 mm	0.025 mm	0.13 mm	0.1 mm
OP	33.4±1.2 mm			

Note: Do not use the M12 mounting screw and the case mounting hole at the same time, or the case may be damaged.

Panel Mount Cross Roller Plunger

Z-15GQ21-B, Z-15HQ21-B, Z-15EQ21-B

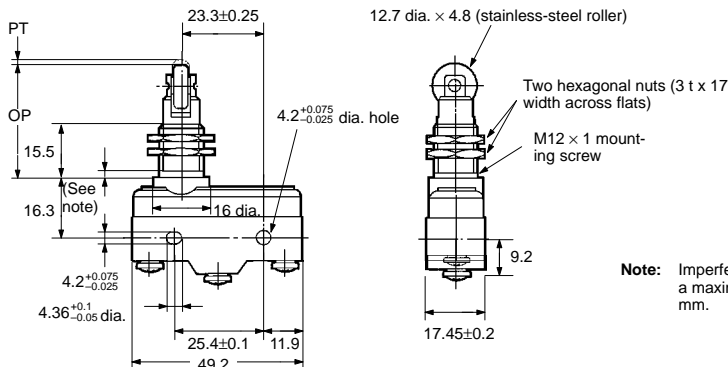
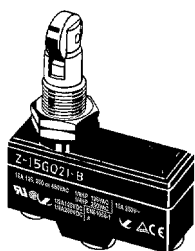

Note: Imperfect screw part with a maximum length of 1.5 mm.

Model	Panel mount cross roller plunger		
	Z-15GQ21-B	Z-15HQ21-B	Z-15EQ21-B
OF	2.45 to 3.43 N {250 to 350 gf}	1.96 to 2.79 N {200 to 285 gf}	6.13 to 7.85 N {625 to 800 gf}
RF min.	1.12 N {114 gf}	1.12 N {114 gf}	1.12 N {114 gf}
PT max.	0.4 mm	0.3 mm	0.8 mm
OT min.	3.58 mm	3.58 mm	3.58 mm
MD max.	0.05 mm	0.025 mm	0.13 mm
OP	33.4±1.2 mm		

Note: Do not use the M12 mounting screw and the case mounting hole at the same time, or the case may be damaged.

Leaf Spring

Z-15GL-B

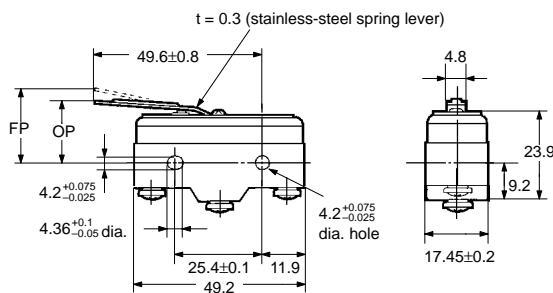
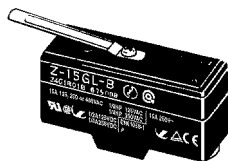

Model	Z-15GL-B
OF max.	1.38 N {141 gf}
RF min.	0.14 N {14 gf}
OT min.	1.6 mm (see note)
MD max.	1.3 mm
FP max.	20.6 mm
OP	17.4±0.8 mm

Note: When operating, be sure not to exceed 1.6 mm.

Roller Leaf Spring

Z-15GL2-B

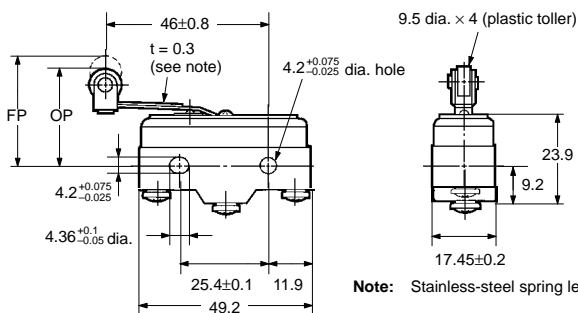
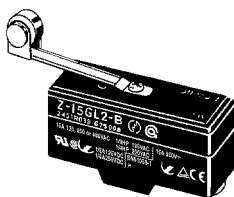

Note: Stainless-steel spring lever

Model	Z-15GL2-B
OF max.	1.38 N {141 gf}
RF min.	0.14 M {14 gf}
OT min.	1.6 mm (see note)
MD max.	1.3 mm
FP max.	31.8 mm
OP	28.6±0.8 mm

Note: When operating, be sure not to exceed 1.6 mm.

Short Hinge Lever

Z-15GW21-B

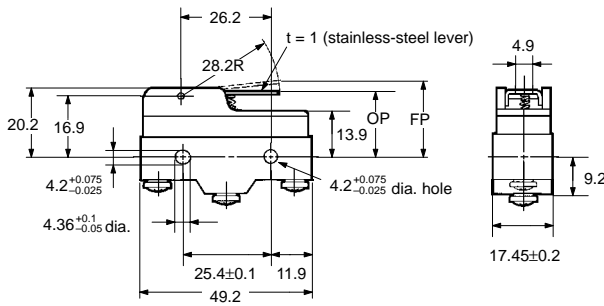
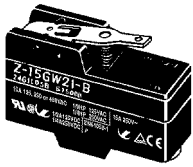

Model	Z-15GW21-B
OF max.	1.57 N {160 gf}
RF min.	0.27 N {28 gf}
OT min.	2 mm
MD max.	1 mm
FP max.	24.8 mm
OP	19 ± 0.8 mm

Hinge Lever

Z-15GW-B, Z-15GW32-B
Z-15HW-B, Z-10FWY-B
Z-15GW3-B (Lever Length: 56R)
(see note)

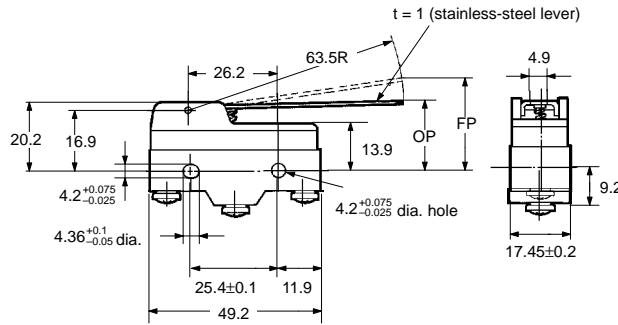
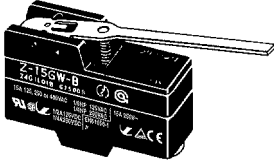

Note: The external dimensions of the actuator vary.

Model	Hinge lever				
	Z-15GW-B	Z-15HW-B	Z-15GW32-B	Z-10FWY-B	Z-15GW3-B
OF max.	0.69 N {70 gf}	0.66 N {67 gf}	1.47 to 1.96 N {150 to 200 gf}	0.88 N {90 gf}	0.78 N {80 gf}
RF min.	0.14 N {14 gf}	0.14 N {14 gf}	0.92 N {94 gf}	0.14 N {14 gf}	0.15 N {15.5 gf}
OT min.	5.6 mm	5.6 mm	5.6 mm	5.6 mm	4.8 mm
MD max.	1.27 mm	0.63 mm	1.27 mm	2.4 mm	1.12 mm
FP max.	28.2 mm	27.4 mm	28.2 mm	29.8 mm	27.2 mm
OP	19 ± 0.8 mm				

Low-force Hinge Lever

Z-15GW4-B

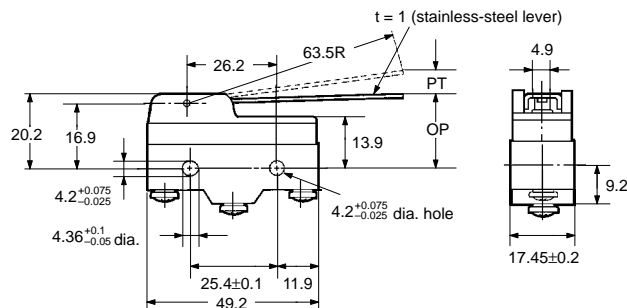
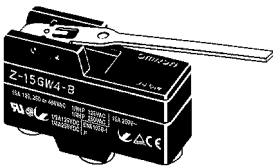

Model	Z-15GW4-B
OF max.	0.274 N {28 gf}
RF min.	0.0343 N {3.5 gf}
PT max.	10 mm
OT min.	5.6 mm
MD max.	1.27 mm
OP	19 ± 0.8 mm

Z-15HW24-B

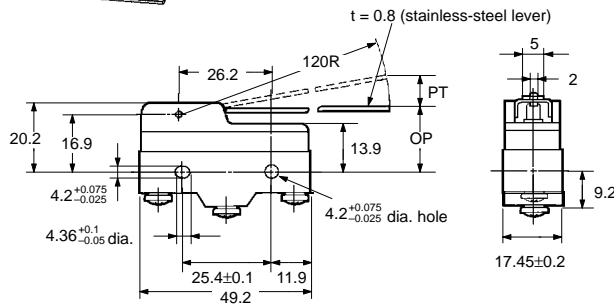
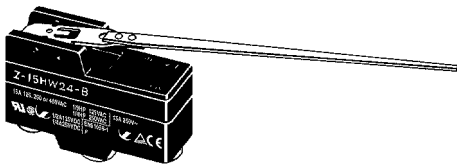

Model	Z-15GW24-B
OF max.	0.0588 N {6 gf}
RF min.	0.0049 N {0.5 gf}
PT max.	19.8 mm
OT min.	10 mm
MD max.	2 mm
OP	19.8 ± 1.6 mm

Low-force Wire Hinge Lever

Z-15HW52-B

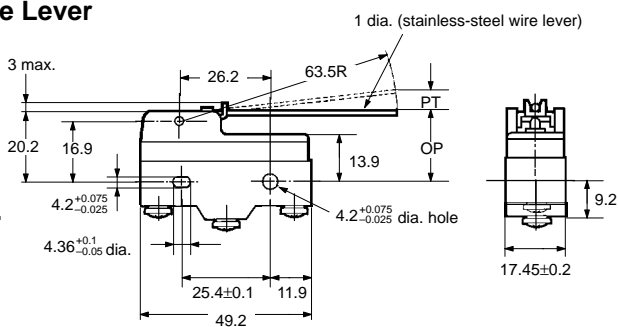
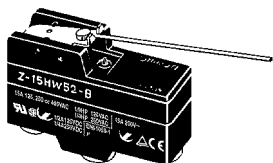

Model	Z-15HW52-B
OF max.	0.0588 N {6 gf}
RF min.	0.0049 N {0.5 gf}
PT max.	8.3 mm
OT min.	5.6 mm
MD max.	0.65 mm
OP	19±1 mm

Z-15HW78-B

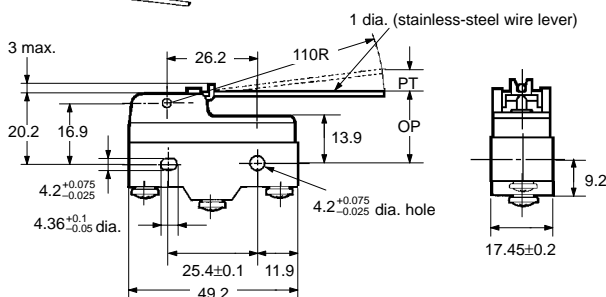
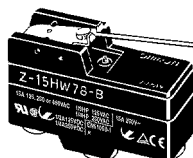

Model	Z-15HW78-B
OF max.	0.0392 N {4 gf}
RF min.	0.00294 N {0.3 gf}
PT max.	10 mm
OT min.	6 mm
MD max.	3 mm
OP	20±1 mm

Note: The AC rating is 10 A at 125 or 250 V.

Short Hinge Roller Lever

Z-15GW22-B, Z-01HW22-B

Z-15HW22-B, Z-10FW22Y-B (see note)

Z-15EW22-B, Z-15GW2-B

Z-15HW2-B (see note), Z-10FW2Y-B (see note)

(Lever Length: 48.5R) (see note)

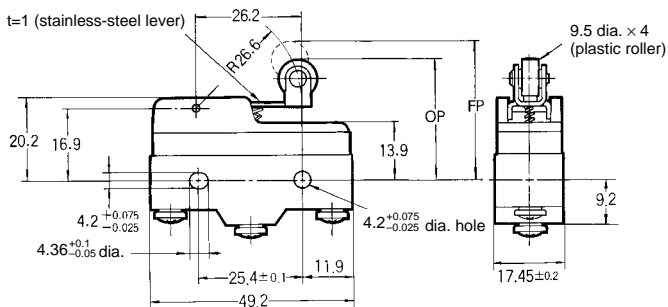
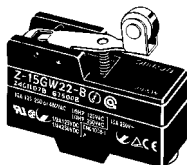

Note: The external dimensions of the actuator vary.

Model	Short hinge roller lever								
	Z-15GW22-B	Z-15HW22-B	Z-15EW22-B	Z-01HW22-B	Z-10FW22Y-B	Z-15GW2-B	Z-15HW2-B	Z-10FW2Y-B	
OF max.	1.57 N {160 gf}	1.47 N {150 gf}	1.94 N {198 gf}	1.57 N {160 gf}	2.45 N {250 gf}	0.98 N {100 gf}	0.84 N {86 gf}	1.27 N {130 gf}	
RF min.	0.41 N {42 gf}	0.41 N {42 gf}	0.41 N {42 gf}	0.27 N {28 gf}	0.34 N {35 gf}	0.22 N {22 gf}	0.22 N {22 gf}	0.22 N {22 gf}	
OT min.	2.4 mm	2.4 mm	2.4 mm	2.4 mm	2.4 mm	4 mm	4 mm	4 mm	
MD max.	0.5 mm	0.45 mm	1.3 mm	0.5 mm	1 mm	1.02 mm	0.6 mm	2 mm	
FP max.	32.5 mm		35.1 mm	32.5 mm	34.8 mm	36.5 mm	37.4 mm		
OP	30.2±0.4 mm					30.2±0.8 mm		30.2±0.8 mm	

Short Hinge Cross Roller Lever

Z-15GW49-B
Z-15GW54-B (Lever Length: 48.7R)
(see note)

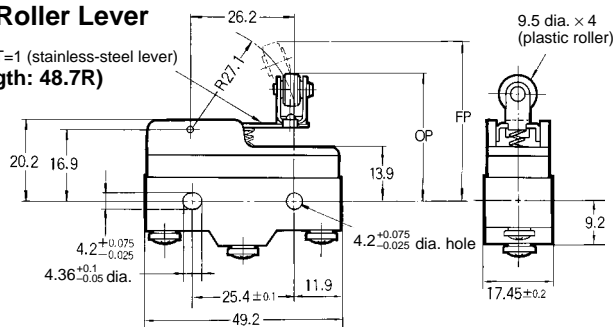
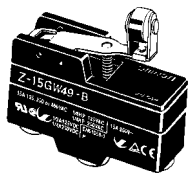

Model	Z-15GW49-B	Z-15GW54-B
OF max.	1.67 N {170 gf}	0.98 N {100 gf}
RF min.	0.41 N {42 gf}	0.22 N {22 gf}
OT min.	2.4 mm	4 mm
MD max.	0.51 mm	1 mm
FP max.	33.3 mm	37.3 mm
OP	31±0.4 mm	31±0.8 mm

Note: The external dimensions of the actuator vary.

Hinge Roller Lever

Z-15GW2-B, Z-10FW2Y-B
Z-15HW2-B

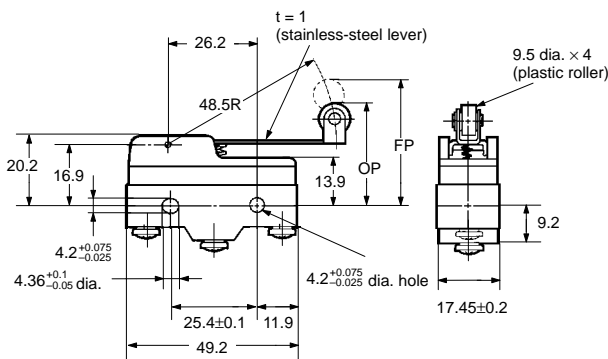
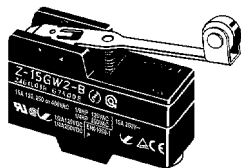

Model	Hinge roller lever		
	Z-15GW2-B	Z-15HW2-B	Z-10FW2Y-B
OF max.	0.98 N {100 gf}	0.84 N {86 gf}	1.27 N {130 gf}
RF min.	0.22 N {22 gf}	0.22 N {22 gf}	0.22 N {22 gf}
OT min.	4 mm	4 mm	4 mm
MD max.	1.02 mm	0.6 mm	2 mm
FP max.	36.5 mm		37.4 mm
OP	30.2±0.8 mm		

Z-15GW25-B

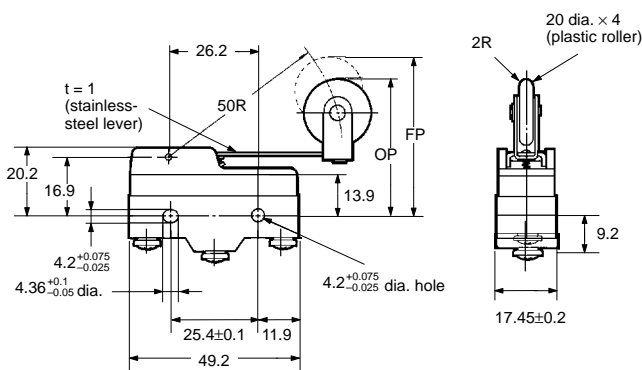
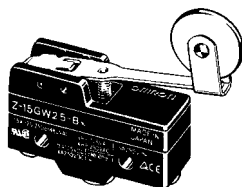

Model	Z-15GW25-B
OF max.	0.98 N {100 gf}
RF min.	0.21 N {21 gf}
OT min.	4 mm
MD max.	1.6 mm
FP max.	47.5 mm
OP	41.2±0.8 mm

Unidirectional Short Hinge Roller Lever

Z-15GW2277-B

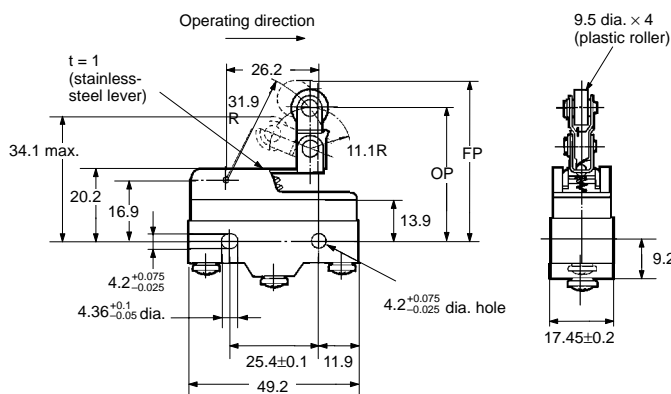
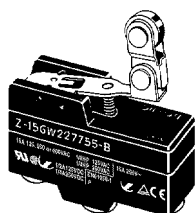

Model	Z-15GW2277-B
OF max.	1.67 N {170 gf}
RF min.	0.41 N {42 gf}
OT min.	2.4 mm
MD max.	0.51 mm
FP max.	43.6 mm
OP	41.3±0.8 mm

Reverse Hinge Lever

Note: The pin plungers of reverse-type models are continuously pressed by the actuator levers with compression coil springs and the pin plungers are freed by operating the levers. Reverse-type models are highly vibration- and shock-resistant because the pin plungers are normally pressed.

Z-15GM-B

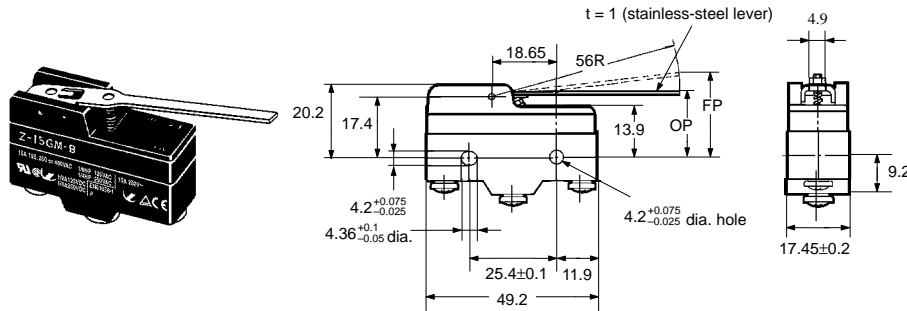

Model	Z-15GM-B
OF max.	1.67 N {170 gf}
RF min.	0.27 N {28 gf}
OT min.	5.6 mm
MD max.	0.89 mm
FP max.	23.8 mm
OP	19±0.8 mm

Reverse Short Hinge Roller Lever

Note: The pin plungers of reverse-type models are continuously pressed by the actuator levers with compression coil springs and the pin plungers are freed by operating the levers. Reverse-type models are highly vibration- and shock-resistant because the pin plungers are normally pressed.

**Z-15GM22-B,
Z-10FM22Y-B**

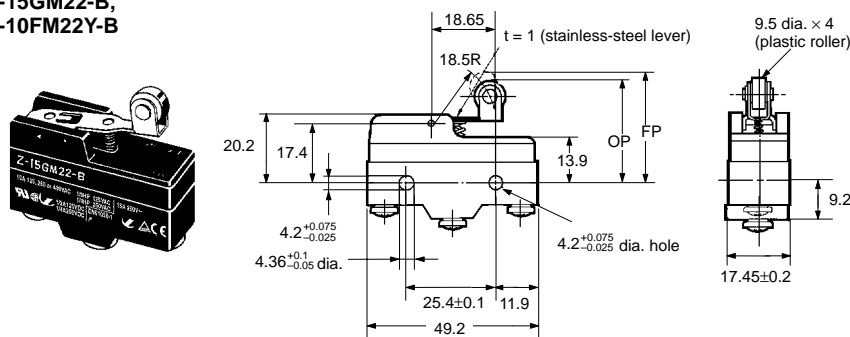

Model	Z-15GM22-B	Z-10FM22Y-B
OF max.	5.28 N {538 gf}	6.37 N {650 gf}
RF min.	1.67 N {170 gf}	
OT min.	2 mm	
MD max.	0.28 mm	0.56 mm
FP max.	31.8 mm	33 mm
OP	29.4±0.4 mm	

Reverse Hinge Roller Lever

Note: The pin plungers of reverse-type models are continuously pressed by the actuator levers with compression coil springs and the pin plungers are freed by operating the levers. Reverse-type models are highly vibration- and shock-resistant because the pin plungers are normally pressed.

Z-15GM2-B

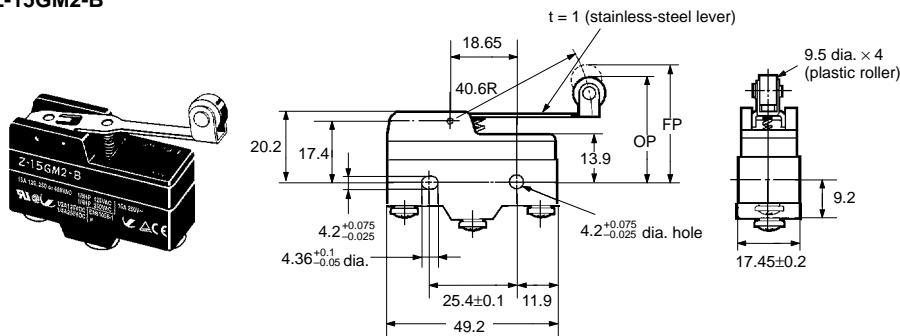

Model	Z-15GM2-B
OF max.	2.35 N {240 gf}
RF min.	0.55 N {56 gf}
OT min.	4 mm
MD max.	0.64 mm
FP max.	35 mm
OP	30.2±0.8 mm

Precautions

■ Caution

Mounting Dimensions

Use M4 screws with flat washers and spring washers to mount the Switch. Tighten each mounting screw securely to a torque of 1.18 to 1.47 N • m {12 to 15 kgf • cm}.

Mounting Holes

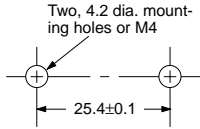

The Switch can be panel mounted, provided that the hexagonal nut of the actuator is tightened to a torque of 2.94 to 4.9 N • m {30 to 50 kgf • cm}.

Panel Mount Plunger

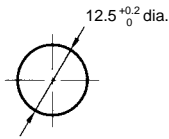

Panel Mount Roller Plunger

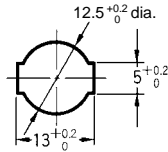

■ Correct Use

Panel Mount Switch (Z-15□Q□, Z-01□Q□)

When mounting the panel mount plunger model with screws on a side surface, be careful of the dog angle and operation speed. Excessive dog angle or operation speed may damage the Switch.

When using the panel mount plunger model mounted with screws on a side surface, be careful not to apply a large shock. Applying a shock exceeding 100G may damage the Switch.

When using the panel mount plunger model mounted with screws on a side surface, remove the hexagonal nuts from the actuator.

High-sensitivity Switch (Z-15H)

When using the Switch in a DC circuit, be sure to provide an arc suppressor as well because the small contact gap of the Switch may result in contact troubles.

In an application where a high repeat accuracy is required, limit the current that flows through the Switch to within 0.1 A. Also, use a relay to control a high-capacity load if the Switch is connected to such a load. (In this case, the exciting current of the relay coil is the load of the Switch.)

Do not apply a force of 19.6 N {2 kgf} or higher to the pin plunger.

Exercise care that the environment conditions such as temperature and humidity do not change abruptly.

Wiring

Models with Drip-proof Terminal Cover (Z-□-B5V)

To attach the Protective Cover to the case, hold the cover in almost parallel to the case and then push it to the case. If the cover is pushed diagonally, the rubber packing may slip off, degrading the sealability of the Switch.

Incorrect

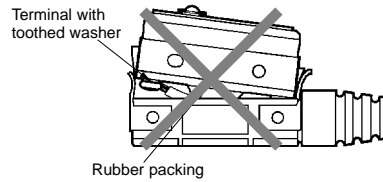

Correct

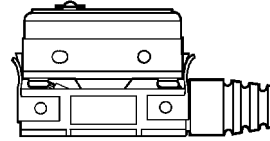

Use round solderless terminals having the following dimensions to connect leads to the terminals. Tighten the screws of terminals to a torque of 0.78 to 1.18 N • m {8 to 12 kgf • cm}.

Use the terminal shown below.

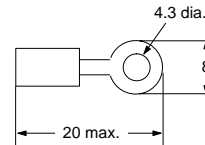

A cable 8.5 to 10.5 mm in diameter can be applicable to the sealing rubber of the lead outlet of the Switch. A two-core or three-core VCT cable having a cross-sectional area of 1.25 mm² is especially suitable for this.

Use M4 small screws with spring toothed washer are used as the terminal screws.

Drip-proof Switch (Z-□55)

The Switch is not perfectly oil-tight; so do not dip it in oil or water.

The rubber boots are made from weather-resistant chloroprene rubber.

Do not use Basic Switches in places with radical changes in temperature.

Split-contact Switch (Z-10F□Y)

The applicable current varies depending on how the contacts are used. If the Switch is connected in series, the Switch can endure a current 1.5 to 2 times higher than the current that can be applied in parallel connection.

Flexible Rod Switch (Z-15□NJ□55, Drip-proof)

When the rod is fully swung, the Switch may operate when the lever returns, causing chattering. Use a circuit that compensates for chattering wherever possible.

Do not switch the rod to the fullest extent when the Switch is to break a power circuit because such a practice may cause metal deposition to occur between the mating contacts of the Switch.

Others

Do not apply an excessive force to the mounting bracket with a screwdriver or a similar object when attaching or detaching the protective cover; otherwise, the cover will be deformed.

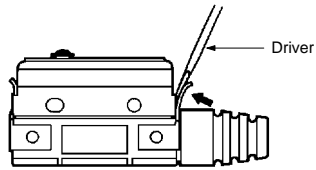

This terminal protective cover cannot be used with models whose model number does not have the prefix “-B5V.”

Terminal protective covers can be ordered separately for maintenance use.

ALL DIMENSIONS SHOWN ARE IN MILLIMETERS.

To convert millimeters into inches, multiply by 0.03937. To convert grams into ounces, multiply by 0.03527.