





Subminiature Basic Switch Conforming to EN61058-1 (IEC1058-1), UL1054, and CSA C22.2 No.54

- A wide operating temperature range of -25°C to 125°C is available for at high-temperature use.
- A wide variety of terminals: Solder, Tab (#110), and PCB Terminal Models.
- PCB Terminal Models are resistant to flux.

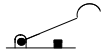

Ordering Information

Actuator	Rating	OF max.	Solder (see note)	Tab (#110)	PCB (see note)
Pin plunger 	0.1 A	1.50 N	SSG-01H	SSG-01T	SSG-01P
		0.50 N	SSG-01H-5	SSG-01T-5	SSG-01P-5
	5 A	1.50 N	SSG-5H	SSG-5T	SSG-5P
		0.50 N	SSG-5H-5	SSG-5T-5	SSG-5P-5
Hinge lever 	0.1 A	0.60 N	SSG-01L1H	SSG-01L1T	SSG-01L1P
		0.20 N	SSG-01L1H-5	SSG-01L1T-5	SSG-01L1P-5
	5 A	0.60 N	SSG-5L1H	SSG-5L1T	SSG-5L1P
		0.20 N	SSG-5L1H-5	SSG-5L1T-5	SSG-5L1P-5
Simulated hinge lever 	0.1 A	0.60 N	SSG-01L3H	SSG-01L3T	SSG-01L3P
		0.20 N	SSG-01L3H-5	SSG-01L3T-5	SSG-01L3P-5
	5 A	0.60 N	SSG-5L3H	SSG-5L3T	SSG-5L3P
		0.20 N	SSG-5L3H-5	SSG-5L3T-5	SSG-5L3P-5
Hinge roller lever 	0.1 A	0.60 N	SSG-01L2H	SSG-01L2T	SSG-01L2P
		0.20 N	SSG-01L2H-5	SSG-01L2T-5	SSG-01L2P-5
	5 A	0.60 N	SSG-5L2H	SSG-5L2T	SSG-5L2P
		0.20 N	SSG-5L2H-5	SSG-5L2T-5	SSG-5L2P-5

Note: EN61058-1 (IEC1058-1) approved by TÜV Rheinland.

Specifications

■ Ratings

1. General Ratings

Rated voltage	Non-inductive load				Inductive load			
	Resistive load		Lamp load		Inductive load		Motor load	
	NC	NO	NC	NO	NC	NO	NC	NO
125 VAC	5 (0.1) A (see note 1)		1.5 A	0.7 A	3 A		2.5 A	1.3 A
250 VAC	3 A		1 A	0.5 A	2 A		1.5 A	0.8 A
8 VDC	5 A		2 A		5 A		3 A	
14 VDC	5 A		2 A		4 A		3 A	
30 VDC	4 (0.1) A (see note 1)		2 A		3 A		3 A	
125 VDC	0.4 A		0.05 A		0.4 A		0.05 A	
250 VDC	0.2 A		0.03 A		0.2 A		0.05 A	

- Note:**
- The values in the parentheses are for the SSG-01.
 - The above current ratings are the values of the steady-state current.
 - Inductive load has a power factor of 0.7 min. (AC) and a time constant of 7 ms max. (DC).
 - Lamp load has an inrush current of 10 times the steady-state current.
 - Motor load has an inrush current of 6 times the steady-state current.
 - If the switch is used in a DC circuit and is subjected to a surge current, connect a surge suppressor across the switch.

2. TÜV Rheinland Approved Rating (EN61058-1/IEC1058-1)

SSG-5 series: 5 A at 250 VAC (T125, 50,000 operations)

SSG-01 series: 0.1 A at 30 VDC (T125, 50,000 operations)

3. UL, CSA Approved Rating

SSG-5 series: 5 A at 125 VAC, 3 A at 250 VAC (6,000 operations)

SSG-01 series: 0.1 A at 125 VAC, 0.1 A at 30 VDC (6,000 operations)

■ Characteristics

Operating speed	0.1 mm to 1 m/s (at pin plunger)
Operating frequency	Mechanical: 400 operations/min Electrical: 60 operations/min
Insulation resistance	100 MΩ min.
Contact resistance	OF 1.50 N: SSG-5 series: 30 mΩ max. SSG-01 series: 50 mΩ max. OF 0.50 N: SSG-5 series: 50 mΩ max. SSG-01 series: 100 mΩ max.
Dielectric strength	1,000 VAC, 50/60 Hz for 1 min between contacts of the same polarity (600 VAC for SSG-01H and SSG-01T series) 1,500 VAC, 50/60 Hz for 1 min between each terminal and ground 1,500 VAC, 50/60 Hz for 1 min between each terminal and non-current-carrying metal part
Inrush current	SSG-5: NO: 20 A max. NC: 10 A max. SSG-01: NO: 1 A max. NC: 1 A max.
Vibration resistance	Malfunction: 10 to 2,000 Hz, 196 m/s ² (20G) (Contact open: 10 μs max., lever position: at TTP)
Shock resistance	Malfunction: 490 m/s ² (approx. 50G) (Contact open: 10 μs max., lever position: at TTP)
Life expectancy	Mechanical: 10,000,000 operations min. (OT: rated value) Electrical: 200,000 operations min. (5 A at 125 VAC for SSG-5, 0.1 A at 125 VAC for SSG-01, resistive OT:full)
Degree of protection (IP code)	IP00 (IEC1058-1)
Degree of protection against electrical shock	Class I (IEC1058-1)
Proof tracking index	175 V (IEC1058-1)
Switch category (IEC335-1)	D (IEC1058-1)

■ Contact

Item	SSG-5	SSG-01
Specification	Rivet	Crossbar
Material	Silver	PGS alloy

■ Safety Standards

Certification body	Standard	File no.
TÜV Rheinland	EN61058-1 (IEC1058-1)	T9451449
UL	UL1054	E32667
CSA	C22.2 No.54	LR21642

■ Operating Characteristics

Solder/Tab Terminal

Type	Pin plunger		Hinge lever		Simulated hinge lever		Hinge roller lever	
	SSG-01□ SSG-5□	SSG-01□-5 SSG-5□-5	SSG-01L1□ SSG-5L1□	SSG-01L1□-5 SSG-5L1□-5	SSG-01L3□ SSG-5L3□	SSG-01L3□-5 SSG-5L3□-5	SSG-01L2□ SSG-5L2□	SSG-01L2□-5 SSG-5L2□-5
OF max.	1.50 N (153 gf)	0.50 N (51 gf)	0.60 N (61 gf)	0.20 N (20 gf)	0.60 N (61 gf)	0.20 N (20 gf)	0.60 N (61 gf)	0.20 N (20 gf)
RF min.	0.25 N (25 gf)	0.04 N (4 gf)	0.06 N (6 gf)	0.02 N (2 gf)	0.06 N (6 gf)	0.02 N (2 gf)	0.06 N (6 gf)	0.02 N (2 gf)
PT max.	0.6 mm		1.0 mm		1.0 mm		1.0 mm	
OT min.	0.4 mm		0.8 mm		0.8 mm		0.8 mm	
MD max.	0.1 mm		---		---		---	
FP max.	---		13.6 mm		15.5 mm		19.0 mm	
OP	8.4±0.3 mm		8.8 ^{+1.0} / _{-0.6} mm		10.7 ^{+1.0} / _{-0.6} mm		14.5 ^{+1.0} / _{-0.6} mm	

PCB Terminal

Type	Pin plunger		Hinge lever		Simulated hinge lever		Hinge roller lever	
	SSG-01P SSG-5P	SSG-01P-5 SSG-5P-5	SSG-01L1P SSG-5L1P	SSG-01L1P-5 SSG-5L1P-5	SSG-01L3P SSG-5L3P	SSG-01L3P-5 SSG-5L3P-5	SSG-01L2P SSG-5L2P	SSG-01L2P-5 SSG-5L2P-5
OF max.	1.50 N (153 gf)	0.50 N (51 gf)	0.60 N (61 gf)	0.20 N (20 gf)	0.60 N (61 gf)	0.20 N (20 gf)	0.60 N (61 gf)	0.20 N (20 gf)
RF min.	0.25 N (25 gf)	0.04 N (4 gf)	0.06 N (6 gf)	0.02 N (2 gf)	0.06 N (6 gf)	0.02 N (2 gf)	0.06 N (6 gf)	0.02 N (2 gf)
PT max.	0.6 mm		1.0 mm		1.0 mm		1.0 mm	
OT min.	0.4 mm		0.8 mm		0.8 mm		0.8 mm	
MD max.	0.1 mm		---		---		---	
FP max.	---		17.0 mm		18.9 mm		22.4 mm	
OP	11.8±0.4 mm		12.2 ^{+1.1} / _{-0.7} mm		14.4 ^{+1.1} / _{-0.7} mm		17.9 ^{+1.1} / _{-0.7} mm	

Dimensions

- Note:**
1. All units are in millimeters unless otherwise indicated.
 2. Every actual model number includes the code instead of □ for the kind of terminals incorporated by the model.
 3. Unless otherwise specified, a tolerance of ± 0.4 mm applies to all dimensions.

■ Terminal Model

Solder/Tab Terminal

Pin Plunger

SSG-01□
 SSG-5□
 SSG-01□-5
 SSG-5□-5

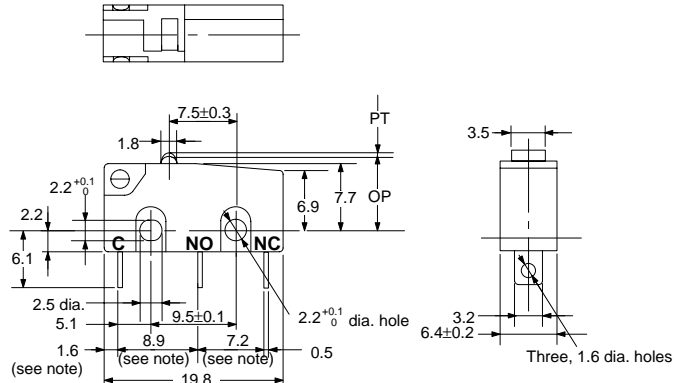
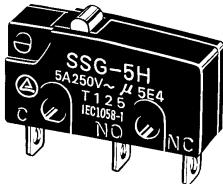

Note: At switch bottom

Hinge Lever

SSG-01L1□
 SSG-5L1□
 SSG-01L1□-5
 SSG-5L1□-5

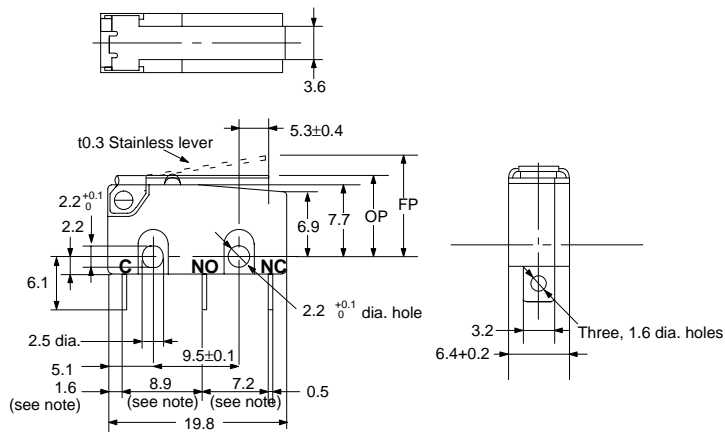
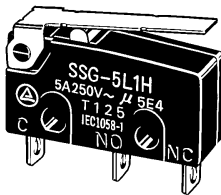

Note: At switch bottom

Simulated Hinge Lever

SSG-01L3□
 SSG-5L3□
 SSG-01L3□-5
 SSG-5L3□-5

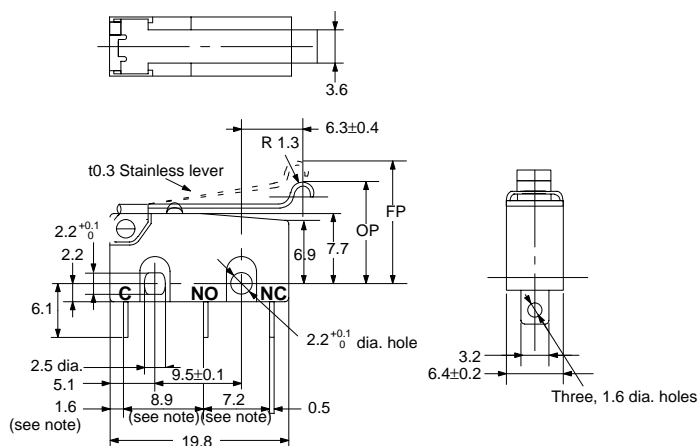
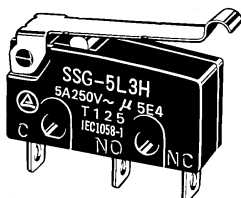

Note: At switch bottom

Hinge Roller Lever

- SSG-01L2□
- SSG-5L2□
- SSG-01L2□-5
- SSG-5L2□-5

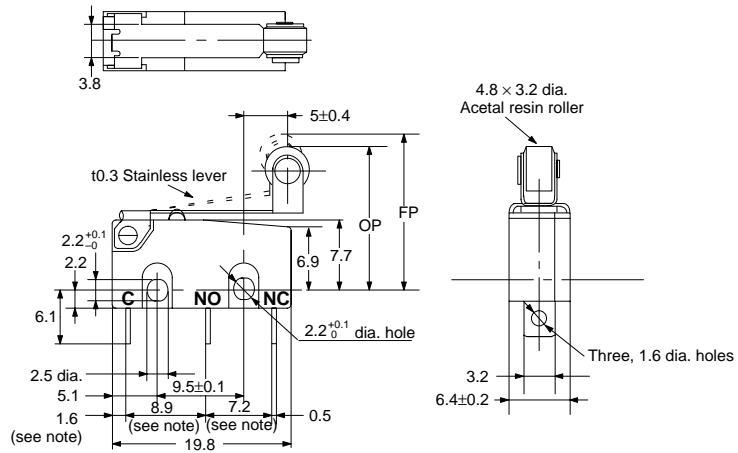
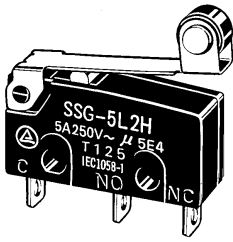

Note: At switch bottom

PCB Terminal

Pin Plunger

- SSG-01P
- SSG-5P
- SSG-01P-5
- SSG-5P-5

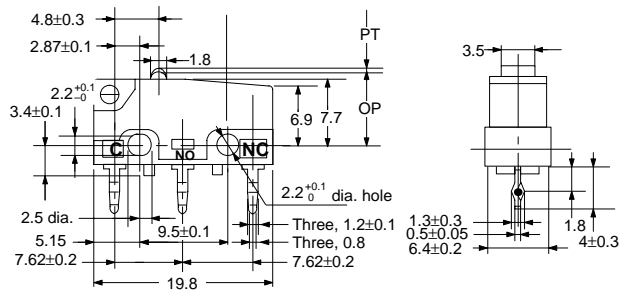

Note: At switch bottom

Hinge Lever

- SSG-01L1P
- SSG-5L1P
- SSG-01L1P-5
- SSG-5L1P-5

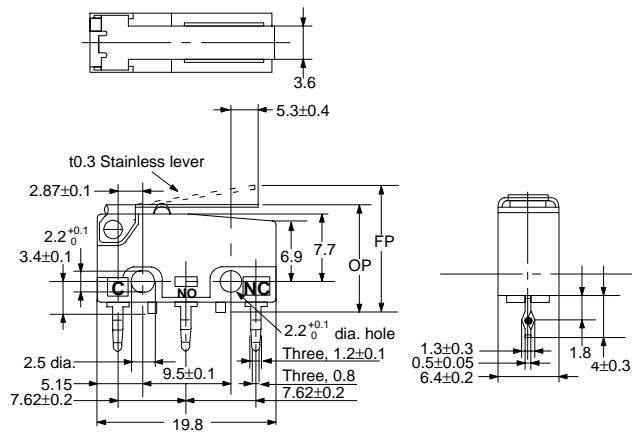
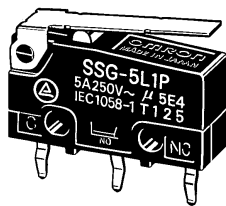

Note: At switch bottom

Simulated Hinge Lever

- SSG-01L3P
- SSG-5L3P
- SSG-01L3P-5
- SSG-5L3P-5

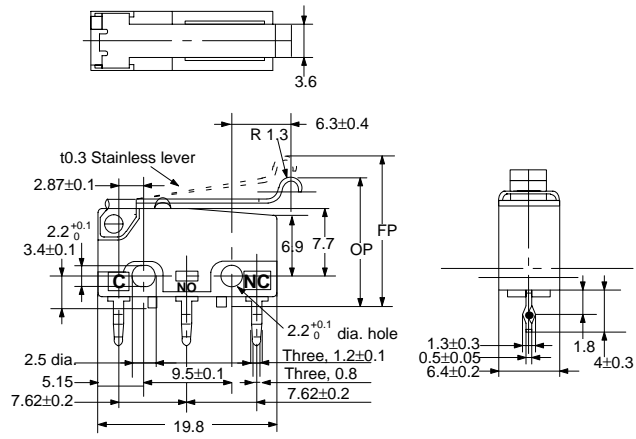
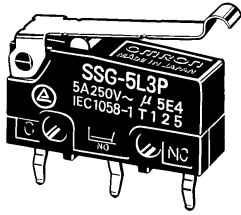

Hinge Roller Lever

- SSG-01L2P
- SSG-5L2P
- SSG-01L2P-5
- SSG-5L2P-5

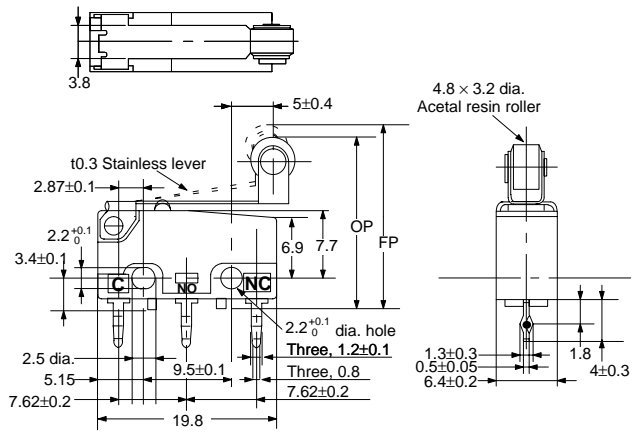
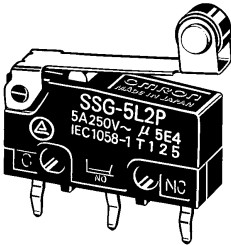

■ Kind of Terminals

Solder Terminals

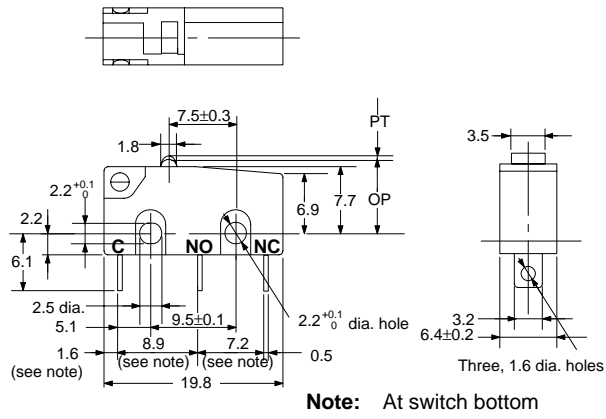

Tab Terminals (#110)

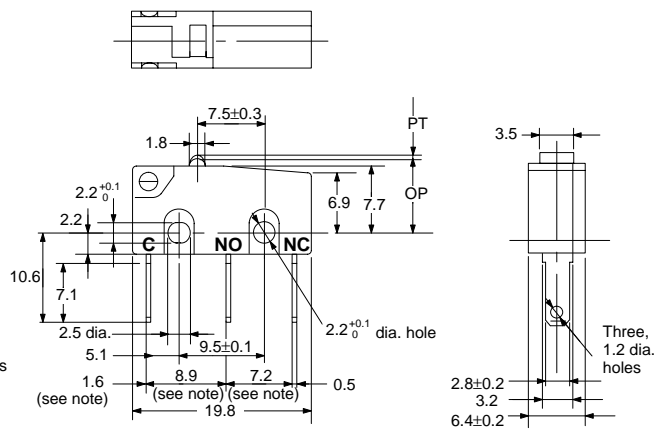

Note: At switch bottom

PCB Terminals

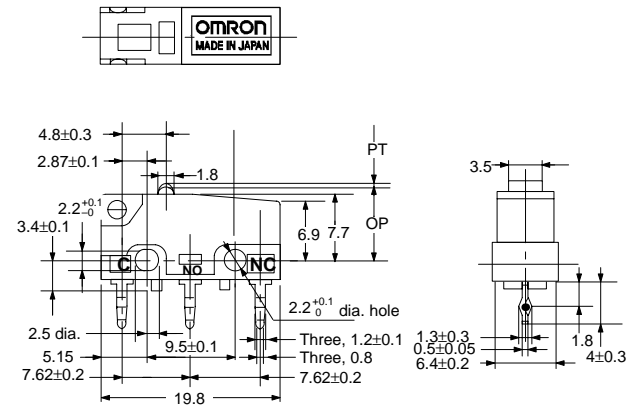

PCB Mounting

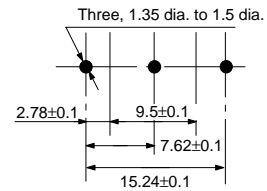

Precautions

Mounting

Use two 2.2 mounting screws with spring washers to mount the switch. Tighten the screws to a torque of 0.20 to 0.25 N • m (2 to 2.5 kgf • cm).

Mounting Holes

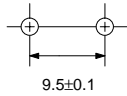

The switch does not have a ground terminal. The minimum distance through insulation (IEC1058-1) is 0.9 mm. If proper insulation for the end product cannot be secured, additional insulation such as a separator or insulation cover should be attached.

Soldering

When soldering switch terminals, apply a soldering iron rated at 60 W max. and finish soldering quickly within 3 seconds. During soldering and 1 minute after soldering, do not apply external force to the terminals.

Solder terminal is provided with a hole so that a conductor can be secured mechanically.

The conductors for a soldering terminal (H type) should be flexible and its cross section should be AWG18 to 20 for the SSG-5H Series and AWG20 to 22 for the SSG-01H Series.

To automatically solder the switch to a PCB in a soldering bath, complete soldering within 5 seconds at a flux temperature of 250°C and avoid the overflow of flux onto the surface of the PCB where the switch or other parts are mounted.

Actuating

Make sure that the operating speed and frequency are within the permissible range of the switch.

1. Do not use the switch in an application where the operating speed is extremely slow or the switching operation could become unstable or malfunctioning could result due to contact failure or contact welding.
2. Do not use the switch in an application where the operating speed is too fast, or the switch will be broken due to a shock or the movable contact will not keep up with the speed.

The reliability of a switch is maintained within the permissible operating speed and frequency of the switch. The life of a switch is determined at a specified operating speed, therefore, it varies with the actual operating speed and frequency.

The switch should be set so that its stroke will be in the range of 60% to 90% of the rated OT when the switch is operated. The stroke must not exceed the rated OT value.

Malfunctioning can result if the switch is set with its stroke exceeding the rated OT. Therefore the proper adjustment of the mounting position is essential when installing the switch.

Do not apply excessive force to the actuator. Be very careful not to apply force in the opposite and lateral directions relative to the operating direction.

ALL DIMENSIONS SHOWN ARE IN MILLIMETERS.

To convert millimeters into inches, multiply by 0.03937. To convert grams into ounces, multiply by 0.03527.