

Low-cost DIP Switch

- The sealed bottom prevents flux penetration.
- A variety of models including models with short or long levers are available.

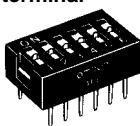
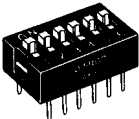
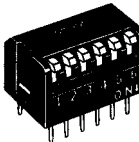
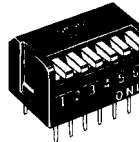

Ordering Information

No. of poles	Flat Actuated	Raised Actuator	Side Actuated (short-lever)	Side Actuated (long-lever)
	DIP terminal 	DIP terminal 	DIP terminal 	DIP terminal 
2	A6E-2101	A6E-2104	A6ER-2101	A6ER-2104
3	A6E-3101	A6E-3104	A6ER-3101	A6ER-3104
4	A6E-4101	A6E-4104	A6ER-4101	A6ER-4104
5	A6E-5101	A6E-5104	A6ER-5101	A6ER-5104
6	A6E-6101	A6E-6104	A6ER-6101	A6ER-6104
7	A6E-7101	A6E-7104	A6ER-7101	A6ER-7104
8	A6E-8101	A6E-8104	A6ER-8101	A6ER-8104
9	A6E-9101	A6E-9104	A6ER-9101	A6ER-9104
10	A6E-0101	A6E-0104	A6ER-0101	A6ER-0104

Specifications

■ Ratings/Characteristics

Switching capacity	25 mA at 24 VDC
Insulation resistance	100 MΩ min. (at 250 VDC)
Contact resistance	200 mΩ max. (initial value)
Dielectric strength	500 VAC for 1 min between terminals of same polarity, and between terminals of different polarity
Vibration resistance	Malfunction: 10 to 55 Hz, 1.5-mm double amplitude
Shock resistance	Malfunction: 300 m/s ² min. (approx. 30G min.)
Life expectancy	Mechanical: 1,000 operations min. Electrical: 1,000 operations min.
Ambient temperature	Operating: -20°C to 70°C (with no icing)
Ambient humidity	Operating: 35% to 90%
Operating force	0.29 N min. (30 gf)

Dimensions

- Note:** 1. All units are in millimeters unless otherwise indicated.
 2. Unless otherwise specified, a tolerance of ± 0.4 mm applies to all dimensions.

Flat Actuated with DIP Terminal

A6E-□101

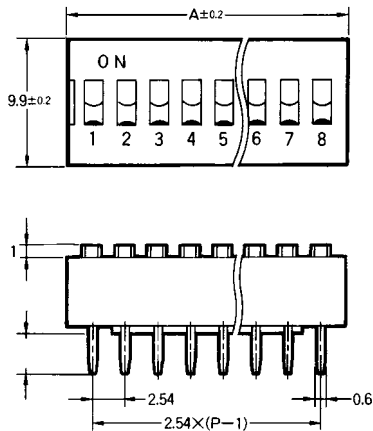
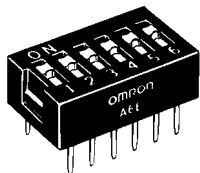

Flat Actuated

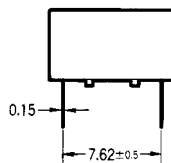

Raised Actuator

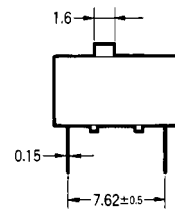

Raised Actuator with DIP Terminal

A6E-□104

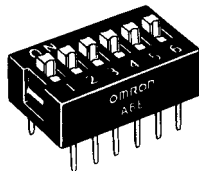

PCB Dimensions
(Top View)

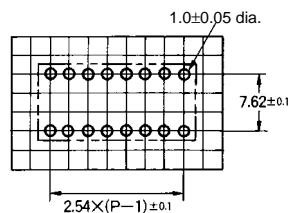

No. of poles	Model		A
2	A6E-2101	A6E-2104	6.64
3	A6E-3101	A6E-3104	9.18
4	A6E-4101	A6E-4104	11.72
5	A6E-5101	A6E-5104	14.26
6	A6E-6101	A6E-6104	16.80
7	A6E-7101	A6E-7104	19.34
8	A6E-8101	A6E-8104	21.88
9	A6E-9101	A6E-9104	24.42
10	A6E-0101	A6E-0104	26.96

**DIP Terminal
Side Actuated (short-lever)**

A6ER-□101

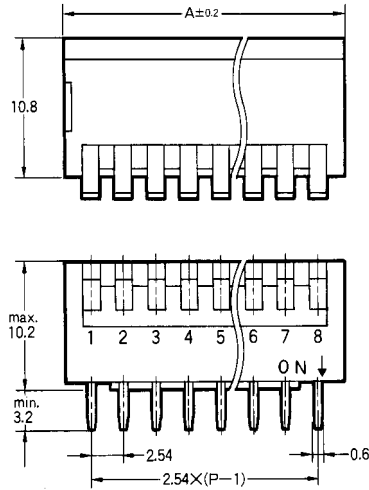
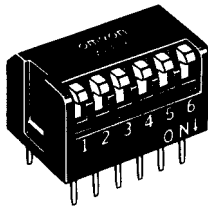

**Side Actuated
(short-lever)**

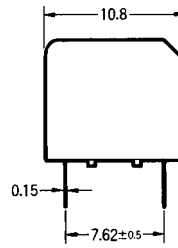

**Side Actuated
(long-lever)**

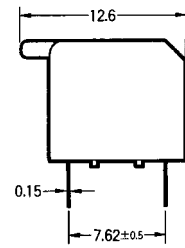

**PCB Dimensions
(Top View)**

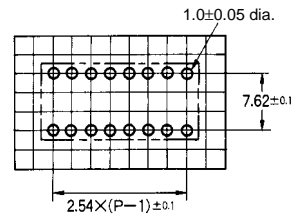

Side Actuated (long-lever)

A6ER-□104

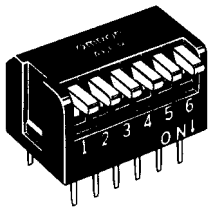

No. of poles	Model		A
2	A6ER-2101	A6ER-2104	6.64
3	A6ER-3101	A6ER-3104	9.18
4	A6ER-4101	A6ER-4104	11.72
5	A6ER-5101	A6ER-5104	14.26
6	A6ER-6101	A6ER-6104	16.80
7	A6ER-7101	A6ER-7104	19.34
8	A6ER-8101	A6ER-8104	21.88
9	A6ER-9101	A6ER-9104	24.42
10	A6ER-0101	A6ER-0104	26.96

Installation

■ Internal Connections (Top View)

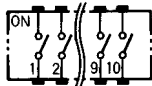

Precautions

Circuit Design

Use the DIP Switch within the rated voltage and current ranges, otherwise the DIP Switch may have a shortened life expectancy, radiate heat, or burn out.

Mounting

Do not operate the DIP Switch while mounting, soldering, or washing the DIP Switch, otherwise the DIP Switch may deform due to the heat of the solder, the DIP Switch may malfunction due to the penetration of the washing agent, or the machine incorporating the DIP Switch may operate or be set incorrectly.

An automatic insertion machine incorporating a body stopper is available for mounting the DIP Switch. When using an automatic insertion machine incorporating a half-lead stopper to mount the DIP Switch, make sure that the automatic insertion machine will not deform the terminals of the DIP Switch, otherwise the improper insertion of the DIP Switch may result.

Soldering

Observe the following conditions when soldering the DIP Switch.

Automatic Soldering Bath

Soldering temperature: 260°C max.
Soldering time: 5 s max. for a 1.6-mm thick, single-side PCB

Reflow Soldering

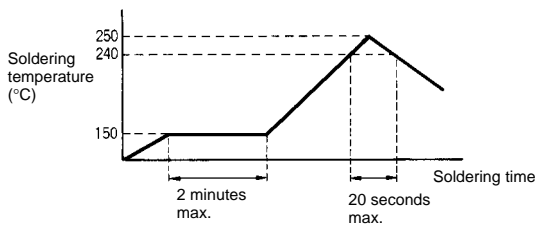

Manual Soldering

Soldering temperature: 350°C at the tip of the soldering iron.
Soldering time: 3 s max. for a 1.6-mm thick, single-side PCB

Set the pins of the DIP Switch to OFF before soldering the DIP Switch.

Before soldering the DIP Switch on a PCB, make sure that there is no unnecessary space between the DIP Switch and PCB.

Before soldering the DIP Switch on a multilayer PCB, make sure that the DIP Switch will not be deformed by the soldering heat on the pattern or land of the multilayer PCB.

Do not solder the DIP Switch more than twice including rectification soldering. An interval of five minutes is required between the first and second solderings.

Make sure that there is no flux rise on the surface of the PCB.

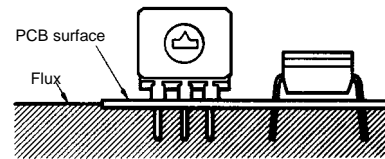

Washing

The A6E/A6ER DIP Switches are not washable.

Handling

Do not apply excessive operating force to the DIP Switch, otherwise the DIP Switch may be damaged or deformed, thus causing the switch mechanism to malfunction as a result. Apply an operating force not exceeding 200% of the maximum rated operating force to the DIP Switch.

Set the DIP Switch incorporating slide pins with a tiny, rounded object, such as the tip of a ball-point pen or small screwdriver. Do not set the DIP Switch using tweezers or any other sharp object, which may damage the DIP Switch. Do not set the DIP Switch using the point of a mechanical pencil, otherwise lead powder or fragments may fall into the DIP Switch and internal circuit board, causing the DIP Switch to malfunction and reducing the dielectric strength of the circuit board.