

PCB Relay

G5C(E)

Flat Relays that Switch 10-A/15-A Loads with New Quick-connect Terminals

- Ideal for switching power in household appliances or for outputs from industrial devices.
- Subminiature dimensions: 22 x 16 x 11 mm (L x W x H).
- High-sensitivity models available with low power consumption (150 mW).
- UL and CSA approved.
- Plastic-sealed models and quick-connect terminal models available (#187 load contact terminals).

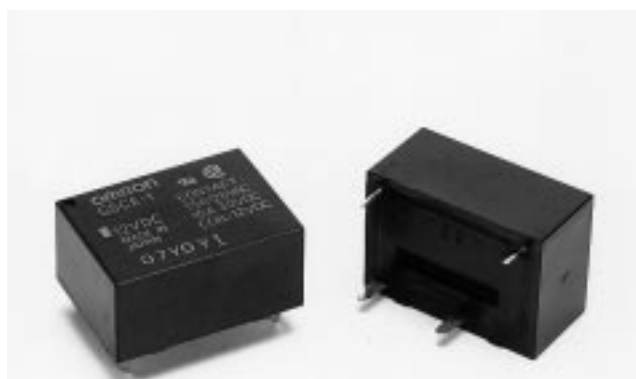

Ordering Information

Contact form	Enclosure rating	General purpose	High-sensitivity	High-capacity	Quick-connect terminals
SPST-NO	Flux protection	G5C-1	G5C-1-H	G5CE-1	G5CE-1-TP
	Plastic-sealed	G5C-14	G5C-14-H	---	---

- Note:**
1. When ordering, add the rated coil voltage to the model number.
Example: G5C-1 12 VDC
Rated coil voltage
 2. High-capacity models with a plastic-sealed structure are not available.
 3. Standard or high-sensitivity models with quick-connect terminals are not available.

Model Number Legend:

G5C - - VDC
1 2 3 4 5

- | | | |
|--|---|---|
| 1. Relay
None: General-purpose
E: High-capacity | 2. Number of Poles
1: 1 pole (SPST-NO) | 4. Series
H: High-sensitivity
TP: Quick-connect terminals (#187) |
| | 3. Enclosure Ratings
None: Flux protection
4: Plastic-sealed | 5. Rated Coil Voltage
3, 5, 6, 12, 24, 48 VDC |

Specifications

■ Coil Ratings

Item	Standard, high-capacity, or quick-connect terminals			High-sensitivity		
	5 VDC	12 VDC	24 VDC	5 VDC	12 VDC	24 VDC
Rated current	40 mA	16.7 mA	8.3 mA	30 mA	12.5 mA	6.25 mA
Coil resistance	125 Ω	720 Ω	2,880 Ω	167 Ω	960 Ω	3,840 Ω
Must operate voltage	75% max. of rated voltage			80% max. of rated voltage		
Must release voltage	10% min. of rated voltage					
Max. voltage	130% (standard)/110% (high-capacity, quick-connect terminals) of rated voltage			130%		
Power consumption	Approx. 200 mW			Approx. 150 mW		

■ Contact Ratings

Item	Standard		High-sensitivity		High-capacity, or quick-connect terminals	
	Resistive load (cosφ = 1)	Inductive load (cosφ = 0.4, L/R = 7 ms)	Resistive load (cosφ = 1)	Inductive load (cosφ = 0.4, L/R = 7 ms)	Resistive load (cosφ = 1)	Inductive load (cosφ = 0.4, L/R = 7 ms)
Rated load	10 A at 250 VAC; 10 A at 30 VDC	3 A at 250 VAC; 3 A at 30 VDC	10 A at 250 VAC; 10 A at 30 VDC	3 A at 250 VAC; 3 A at 30 VDC	15 A at 110 VAC; 10 A at 30 VDC	5 A at 110 VAC; 3 A at 30 VDC
Rated carry current	10 A		10 A		15 A	
Max. switching voltage	250 VAC		250 VAC		250 VAC	
Max. switching current	10 A		10 A		15 A	
Max. switching capacity	2,500 VA, 300 W	750 VA, 90 W	2,500 VA, 300 W	750 VA, 90 W	2,500 VA, 300 W	750 VA, 90 W

■ Characteristics

Contact resistance	30 mΩ max.
Operate time	10 ms max. (High-sensitivity type: 15 ms max.)
Release time	10 ms max.
Insulation resistance	1,000 MΩ min.
Dielectric strength	2,500 VAC, 50/60 Hz for 1 min between contacts of same polarity 1,000 VAC, 50/60 Hz for 1 min between contacts of same polarity
Impulse withstand voltage	4,500 V, 1.2 x 50 μ sec
Vibration resistance	Destruction: 10 to 55 Hz, 1.5-mm double amplitude Malfunction: 10 to 55 Hz, 1.5-mm double amplitude
Shock resistance	Destruction: 1,000 m/s ² (approx. 100G) Malfunction: 200 m/s ² (approx. 20G)
Life expectancy	Mechanical: 20,000,000 operations min. at 18,000 operations/hr Electrical: 300,000 operations min. (100,000 operations min. for Plastic-sealed Type) at 1,200 operations/hr under rated load of 10 A at 250 VAC; 100,000 operations min. under load of 15 A at 110 VAC for high-capacity models 100,000 operations min. at 1,200 operations/hr under rated load of 10 A at 30 VDC
Ambient temperature	Operating: -25°C to 70°C (with no icing) Storage: -25°C to 70°C
Ambient humidity	Operating: 35% to 85%
Weight	Approx. 8 g (for TP model: Approx. 9.6 g)

- Note:** 1. The rated current and coil resistance are measured at a coil temperature of 23°C with a tolerance of ±10%.
2. Operating characteristics are measured at a coil temperature of 23°C.

■ Approved Standards

UL508 (file No. E41515)/CSA C22.2 No.14 (file No. LR31928)

Coil rating	Contact rating
3 to 100 VDC	15 A, 125 VAC 10 A, 250 VAC 10 A, 30 VDC (resistive load only)

Engineering Data

Max. Switching Capacity

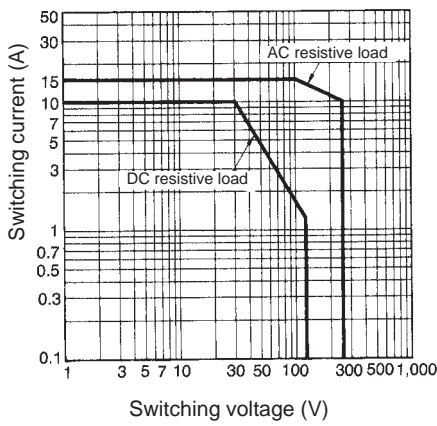

Electrical Life Expectancy

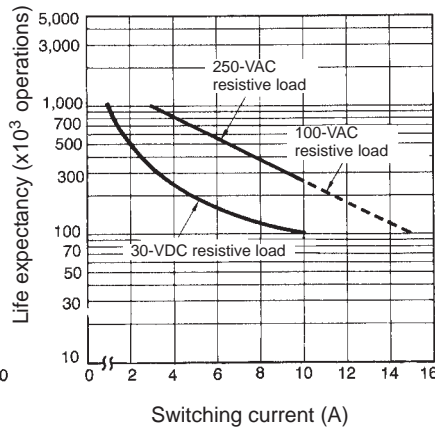

Ambient Temperature vs. Maximum Voltage

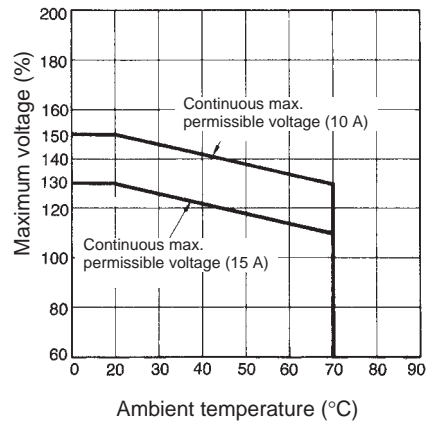

Dimensions

- Note: 1. All units are in millimeters unless otherwise indicated.
2. Orientation marks are indicated as follows:

G5C(E)-1

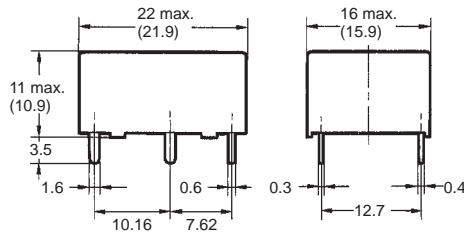
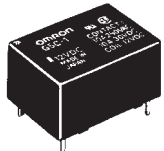

Terminal Arrangement/Internal Connections (Bottom View)

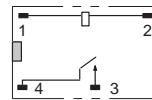

Mounting Holes (PCB)

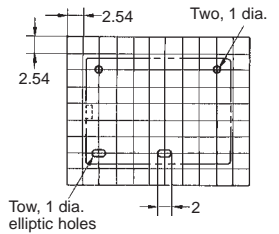

G5CE-1-TP

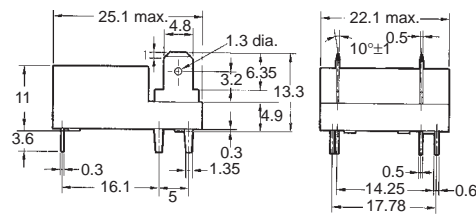
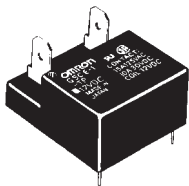

Terminal Arrangement/Internal Connections

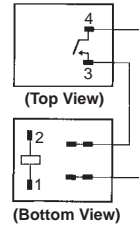

Mounting Holes (Bottom View)

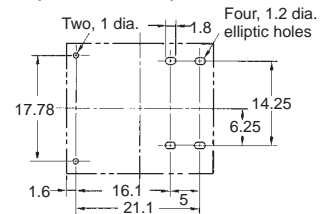

Precautions

Quick-connect Terminals

The quick-connect terminals can be connected to an appropriate load. Consult your OMRON representative, however, when you intend to impose voltage on the quick-connect terminals mounted on a PCB.

The terminals are compatible to the Fasten receptacle #187 positive block connector.

The portion marked with oblique lines includes the charged terminals of the power relay. When you mount the power relay on a PCB, make sure any unnecessary metal patterns on the PCB are kept away from this portion.

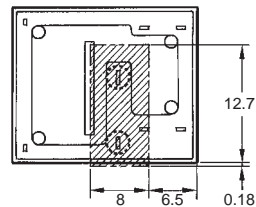

ALL DIMENSIONS SHOWN ARE IN MILLIMETERS.

To convert millimeters into inches, multiply by 0.03937. To convert grams into ounces, multiply by 0.03527.