

Mark Sensor

E3M-V

E3M-V

- Detects laminated or light-dispersing objects in stable operation without being influenced by mirror reflection.
- Double indication of the detection level and threshold level allows easy grasp of the operating status and easy adjustment.
- Automatically sets to the optimum threshold level while sensing objects are being conveyed and incorporates an auto-teaching function that discriminates between the mark and background and turns ON when the mark is detected.
- IP67 watertight construction with M12 rotary connector
- High response speed of 50 μ s and half the size of OMRON's conventional models.



Applications



Dependably Detects Marks on Laminated Sheets

The coaxial optical system ensures a long sensing distance and stable sensing characteristics over a wide angle range, even for objects that are distance-fluctuating or leaning at an angle, or for laminated objects with marks, which conventional models have difficulty in detecting

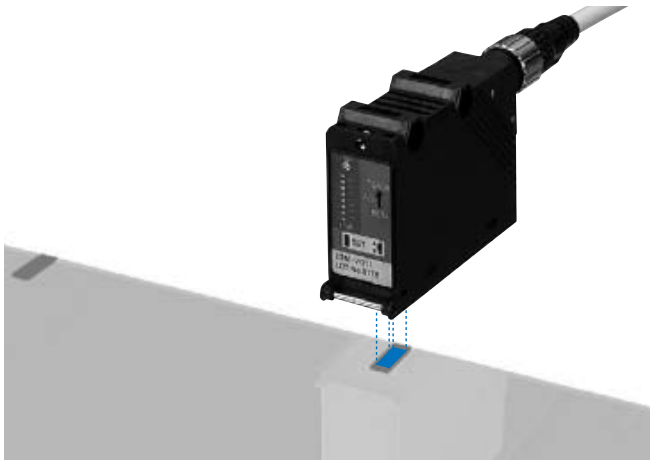



Auto-Teaching

An auto-teaching function automatically sets the threshold value upon a Remote Control input while the workpiece is moving. There is no need to position the mark at the optical spot.

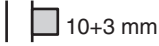

Ordering Information

Sensors



Shape	Connection method	Setting distance	Spot diameter	Model	
				NPN output	PNP output
	Connector type ¹	 10+3 mm	1 x 4 mm	E3M-VG11	E3M-VG16
			4 x 1 mm	E3M-VG21	E3M-VG26
	Pre-wired		1 x 4 mm	E3M-VG12	E3M-VG17
			4 x 1 mm	E3M-VG22	E3M-VG27

¹ Possible to switch between vertical or horizontal connection using the M12 rotary connector

Mounting Brackets

Shape	Model	Quantity	Remarks
	E39-L131	1	
	E39-L132	1	For rear mounting

Sensor I/O Connectors

Shape	Type	Cord type		Model
	Single-end connector (Straight)	2 m	4-wire cord	XS2F-D421-D80-A
		5 m		XS2F-D421-G80-A
	Single-end connector (L-shaped)	2 m		XS2F-D422-D80-A
		5 m		XS2F-D422-G80-A

Specifications

Ratings/Characteristics

Item	E3M-VG11	E3M-VG12	E3M-VG21	E3M-VG22	E3M-VG16	E3M-VG17	E3M-VG26	E3M-VG27
Sensing distance	10±3 mm							
Spot size (W x H)	1 x 4 mm		4 x 1 mm		1 x 4 mm		4 x 1 mm	
Light source (wave-length)	Green LED (525 nm)							
Power supply voltage	10 to 30 VDC, ripple (p-p) 10% max.							
Current consumption	100 mA max.							
Control output	Load power supply voltage: 30 VDC max. Load current: 100 mA max. (Residual voltage: 1.2 V max.) NPN open collector output type				Load power supply voltage: 30 VDC max. Load current: 100 ma max. (Residual voltage: 2 V max.) PNP open collector output type			
Remote control input ¹	ON: Short-circuited to 0 or 1.5 V max. (with a flow current of 1 mA max.) OFF: Open or V _{CC} - 1.5 V to V _{CC} (with a leakage current of 0.1 mA max.)				ON: V _{CC} - 1.5 V to V _{CC} (with an absorption current of 3 mA max.) OFF: Open or 1.5 V max. (with a leakage of 0.1 mA max.)			
Remote control output ¹	Load power supply voltage: 30 VDC max. Load current: 100 mA max. (Residual voltage: 1.2 V max.) NPN open collector output type				Load power supply voltage: 30 VDC max. Load current: 100 ma max. (Residual voltage: 2 V max.) PNP open collector output type			
Bank selection	Two banks selectable. Available for remote control only. (Refer to Remote Control Function.)							
Circuit protection	Protection from reversed power supply connection and load short-circuit							
Response time	ON: 50 μs max. OFF: 70 μs max.							
Ambient illumination (on receiver lens)	Incandescent lamp: 3,000 lx max. Sunlight: 10,000 lx max.							
Ambient temperature	Operating: -20°C to 55°C/Storage: -30°C to 70°C (with no icing)							
Ambient humidity	Operating: 35% to 85%/Storage: 35% to 95°C (with no condensation)							
Insulation resistance	20 M min. (at 500 VDC)							
Dielectric strength	1,000 VAC, 50/60Hz, 1 min.							
Vibration resistance ²	Destruction: 10 to 55 Hz, 1-mm double amplitude or 150 m/s ² for 2 hrs each in X, Y, and Z directions							
Shock resistance ³	Destruction: 500 m/s ² 3 times each in X, Y, and Z directions							
Degree of protection	IEC60529 IP67 (with protective cover)							
Connection method	Connector	Pre-wired	Connector	Pre-wired	Connector	Pre-wired	Connector	Pre-wired
Weight with package box	Approx. 100 g							
Material	Case: Polybutylene terephthalate Lens: Acrylic (PMMA)							
Others	Instruction manual							

¹. Remote control input and answer-back output share the same signal line.

². The Sensor withstands 0.75 mm double amplitude or 100 m/s² if the mounting bracket is attached to the sensor

³. The Sensor withstands 300 m/s² if the mounting bracket is attached to the sensor.

Engineering Data

Sensing Distance vs. Incident Characteristics (Typical)
E3M-VG1□

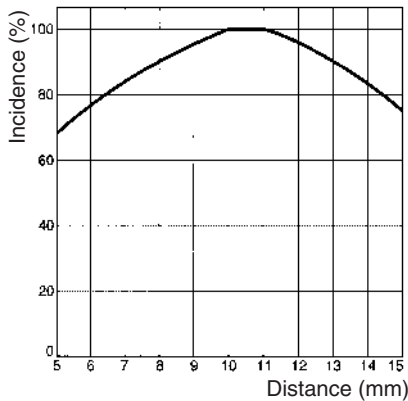

Angle vs. Incident Characteristics (X Direction)
E3M-VG1□/VG2□

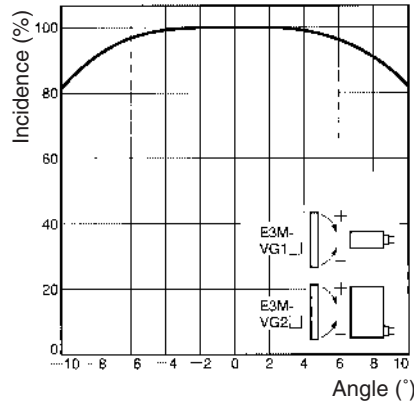

Angle vs. Incident Characteristics (Y Direction)
E3M-VG1□/VG2□

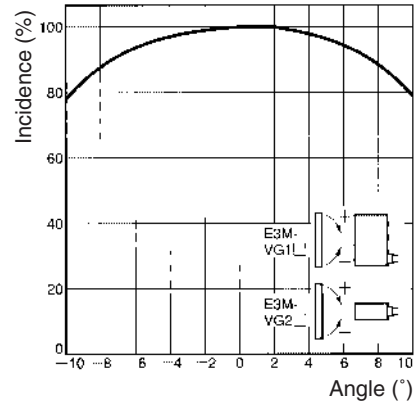

Color Sensing Capacity
E3M-VG□□

	White	Red	Yellow red	Yellow	Yellow green	Green	Blue green	Blue	Purple	Red purple	Black
White	○	○	○	○	○	○	○	○	○	○	○
Red	○	○	○	○	○	○	○	○	○	X	△
Yellow red	○	○	○	○	○	○	○	○	X	○	○
Yellow	○	○	○	○	○	○	○	○	○	○	○
Green yellow	○	○	○	○	○	○	○	○	○	○	○
Green	○	○	○	○	○	○	○	○	○	○	○
Blue green	○	○	○	○	○	○	○	△	○	○	○
Blue	○	○	○	○	○	○	△	△	○	○	○
Purple	○	○	X	○	○	○	○	△	△	○	○
Red purple	○	X	○	○	○	○	○	○	○	○	X
Black	○	△	○	○	○	○	○	○	○	X	○

○: Detectable △: Detectable but unstable X: Not detectable

Differences in Incident by Color

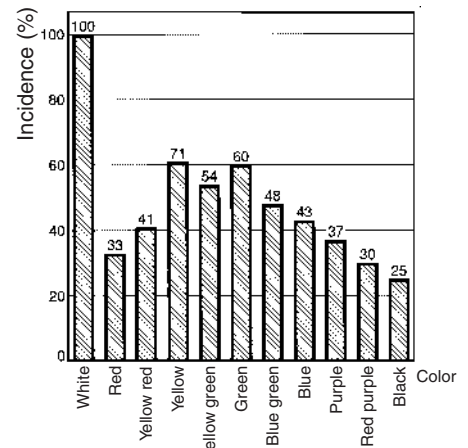

Technical Guide

Glossy Sensing Objects

Incline the Sensor to detect glossy objects so that the Sensor will not be influenced by the mirror reflection of light and to ensure the stable sensing operation of the E3M-V.

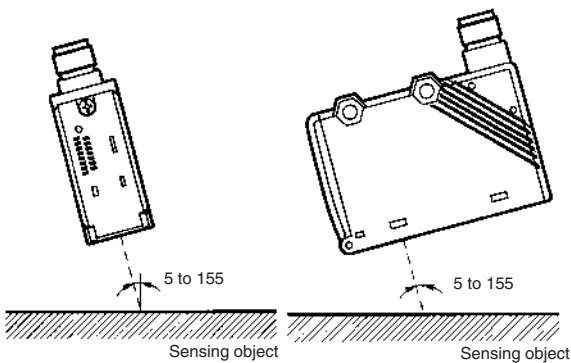

Standard Sensing Object (Color vs. Munsell)
Japan Color Enterprises Standard Color Card 230

11 standard colors	Munsell color notation
White	N9.5
Red	4R, 4.5/12.0
Yellow red	4YR, 6.0/11.5
Yellow	5Y, 8.5/11.0
Yellow green	3GY, 6.5/10.0
Green	3G, 6.5/9.0
Blue green	5BG, 4.5/10.0
Blue	3PB, 5.0/10.0
Purple	7P, 5.0/10.0
Red purple	6RP, 4.5/12.5
Black	N2.0

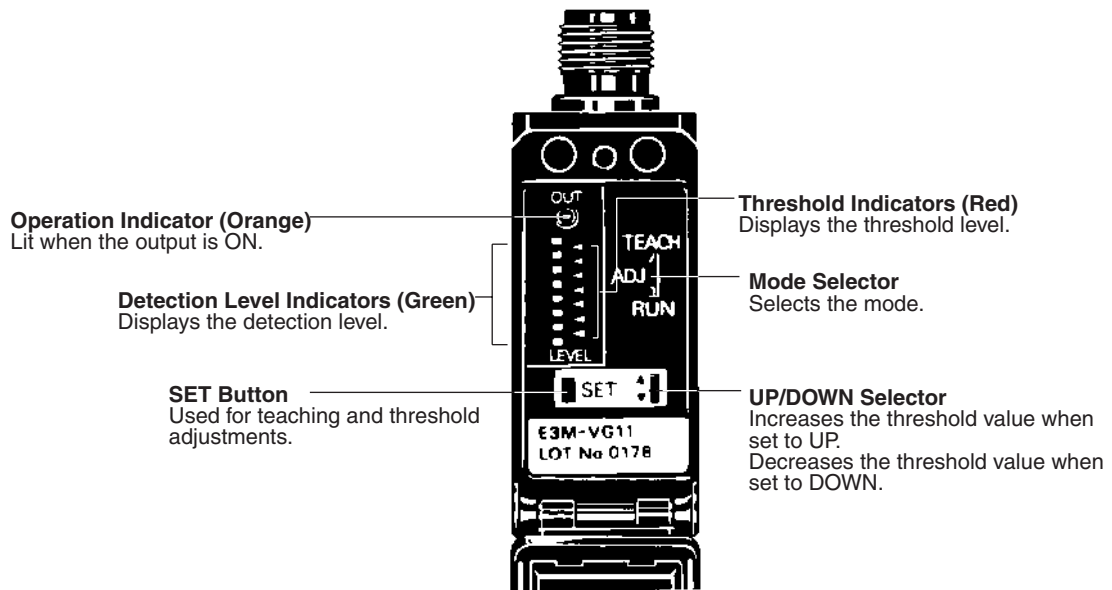

Operation

Output Circuits

NPN (E3M-VG11, E3M-VG12, E3M-VG21, E3M-VG22)

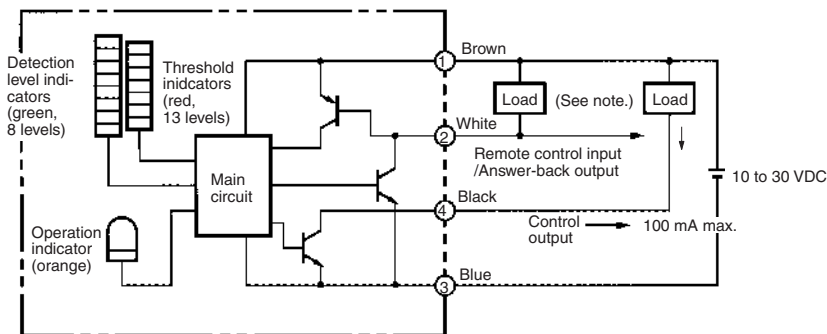

Connector Pin Arrangement

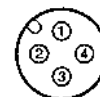

PNP (E3M-VG16, E3M-VG17, E3M-VG26, E3M-VG27)

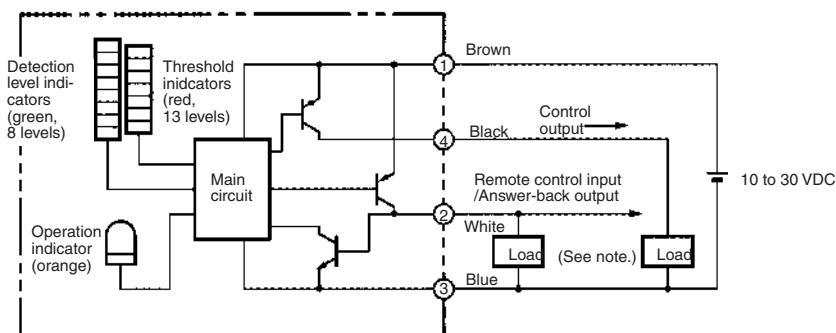

Adjustments

Adjustment Steps

1. Install, wire, and turn ON the Photomicrosensor.
2. Perform teaching (mark registration). Refer to *Mark Registration (Teaching)*.

Mark Registration (Teaching)

Refer to the following for ideal teaching.

Application		
The base has a color pattern. The mark and base are clearly different in color.	The base has no color pattern. The mark and base are slightly different in color.	The base has no color pattern. Remote teaching with no positioning is desired.

One-point teaching	Two-point teaching	Auto-teaching
The default level is set and the output is ON when the mark is detected.	The threshold level is set between the color of the mark and base. The output is ON when the mark is detected.	The threshold level is set between color of the mark and base. The output is ON when the mark (i.e., the color with shorter passing time) is detected.

Refer to the following for each teaching method. Remote one- or two-point teaching is possible. Refer to *Remote Control Function*.

One-point Teaching

1	Set the mode selector to TEACH.
2	Locate the mark to the sensing position and press the SET button. Then all the red threshold indicators are ON.

Red threshold indicators are ON.

3	Set the mode selector to RUN. The output will be ON whenever the set mark is detected.
---	----------------------------------------------------------------------------------------

Note: By teaching on the base, reversed output as shown above (base: ON, mark: OFF) can be obtained.

3. Make fine adjustments of the threshold level if necessary. Refer to *Threshold Level Adjustments* on page A-139 .
4. Check that the mode selector is set to RUN.

Two-point Teaching

1	Set the mode selector to TEACH.
2	Locate the mark to the sensing position and press the SET button. All the red threshold indicators will turn ON.

Red threshold indicators are ON.

3	<p>If teaching is successful, move the mark and press the SET button at the base.</p> <ul style="list-style-type: none"> • If teaching is successful, all the green detection level indicators are ON. • If teaching is unsuccessful, all the red threshold level indicators flash.
---	-------------------------------------------------------------------------------------------------------------------------------------------------------------------------------------------------------------------------------------------------------------------------------------------------------------

Green detection level indicators are ON.

Teaching is OK

Teaching is NG

All the red threshold level indicators will flash if there is no difference in incident.

4	If teaching is successful, set the mode selector to RUN to complete the teaching operation. If teaching is unsuccessful, restart from the above step 2.
---	---------------------------------------------------------------------------------------------------------------------------------------------------------

Note: Follow the above steps so that the output will be turned ON whenever the mark is detected. By taking the opposite steps, the output will be turned OFF whenever the mark is detected and turned ON whenever the base is detected.

Auto-teaching

1. Check that the mode selector is set to either RUN or ADJUST.
2. Input a 0.9-s pulse signal into the remote control I/O terminal.¹
3. Auto-teaching starts when the mark is moved. When the mark passes six times, auto-teaching completes.
 - If teaching is successful, answer-back output from the remote control I/O terminal will turn ON for 0.3 s.
 - If teaching is unsuccessful, no answer-back signal will be output. Readjust using two-point teaching. (Teaching will be unsuccessful if there is no difference in incident between the mark and base.)
4. If the answer-back signal is ON, the whole teaching operation will be completed. The output will be turned ON whenever the mark (i.e., the color with shorter passing time) is detected.

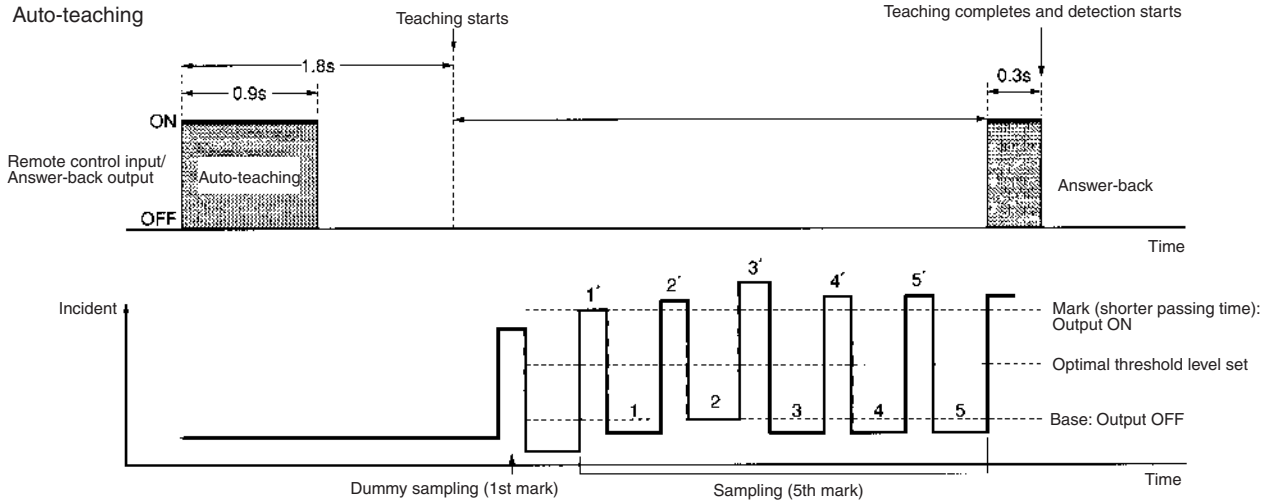

Example of Connection to Programmable Controller

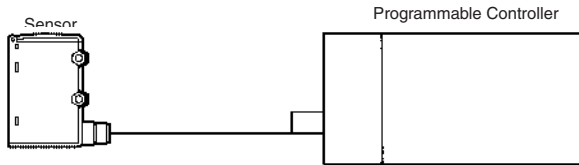

Note: Be sure to connect the E3M-V to the Programmable Controller as shown above.

Precautions when Using Automatic Teaching

Incorrect discrimination may be caused by automatic teaching in the following cases. Use one-point or two-point teaching in such cases.

- Color patterns exist in the base.
- Sensing objects change their positions.
- Sensing objects have protrusions or surface level differences.

Threshold Level Adjustments

It is possible to make fine adjustments of the threshold level after teaching. Such fine adjustments can be made remotely as well. Refer to *Remote control Function (Bank Selection, Mark Registration, and Threshold Adjustments)* on page A-140 .

1 Set the mode selector to ADJUST

Select the upper or lower threshold selector. Whenever the SET button is pressed, the threshold level will move. Two indicators will be lit together when the threshold level is an even level.

Threshold indicators	▲▲▲▲▲▲▲▲	▲▲▲▲▲▲▲▲	▲▲▲▲▲▲▲▲	▲▲▲▲▲▲▲▲	▲▲▲▲▲▲▲▲	▲▲▲▲▲▲▲▲	▲▲▲▲▲▲▲▲	▲▲▲▲▲▲▲▲	▲▲▲▲▲▲▲▲	▲▲▲▲▲▲▲▲	▲▲▲▲▲▲▲▲	▲▲▲▲▲▲▲▲	▲▲▲▲▲▲▲▲
Threshold level	1	2	3	4	5	6	7	8	9	10	11	12	13

2

3 After setting the level, set the mode selector to RUN.

¹ Make sure that the input tolerance of each pulse is within ± 0.1 s.

Detection Level Indicator

Detection Level Indicator

The control output of the E3M-V will be turned ON if the detection level exceeds the threshold level. The indication of the detection level varies with the teaching method.

One-point Teaching

The upper and lower threshold values are set on the basis of the mark (registered first) and the base (registered next). The detection level indicators indicate the degree of color conformity to the mark's color.

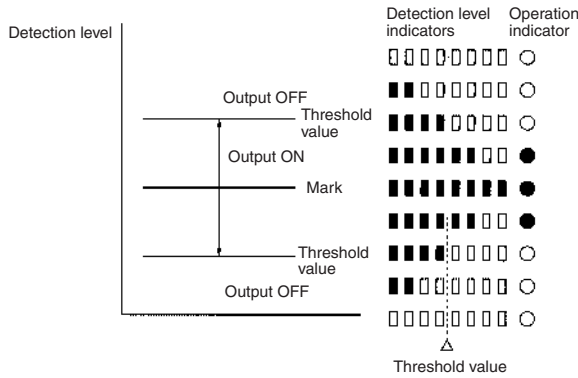

Two-point or Auto-teaching

A single threshold value is set between the mark (registered first) and the base (registered next). The detection level indicators indicate the tolerance between the mark and base.

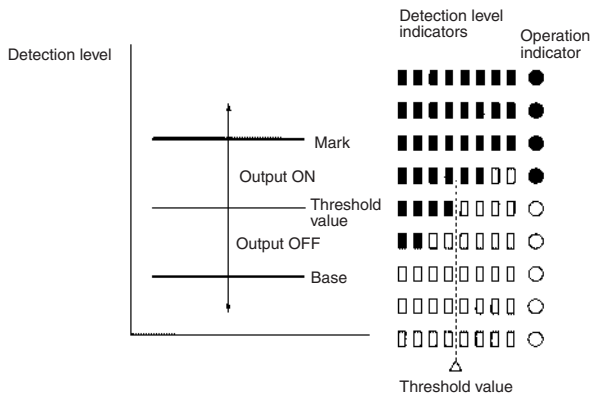

Remote control Function (Bank Selection, Mark Registration, and Threshold Adjustments)

Under Run Mode or Adjust Mode

The input of any of the signals listed in the following table into the remote control I/O terminal allows remote control of the E3M-V. When the signal is accepted, answer-back output will be turned ON for 0.3 s. Only in the case of one-point teaching, however, can the signal be manually input, provided that the input is ON for 1.5 s or more.

Timing Chart

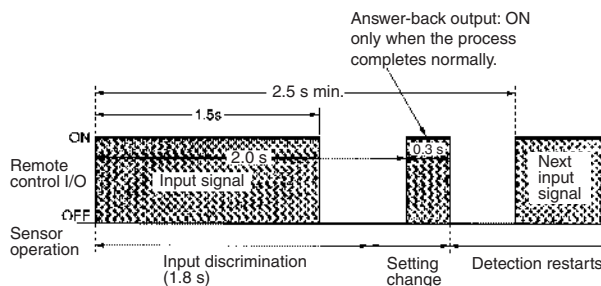

Note: If Signals are sent continuously, make sure that there is an interval of 2.5 s between signal inputs as shown above.

Control Signals

No.	Control signal	Function
1		Bank 1 is selected (operation indicator OFF in TEACH mode)
2		Bank 2 is selected (operation indicator ON in TEACH mode)
3		Auto-teaching
4		Two-point teaching (1st and 2nd)
5		One-point teaching (or input for 1.5 s min.)
6		Threshold level 1 is selected.
7		Threshold level 3 is selected.
8		Threshold level 5 is selected.
9		Threshold level 7 is selected.
10		Threshold level 9 is selected.
11		Threshold level 11 is selected.
12		Threshold level 13 is selected.

Note: The input error of each signal pulse must be within ± 0.1 s

Ladder Program Example

Control signals are input by a ladder program as shown below.

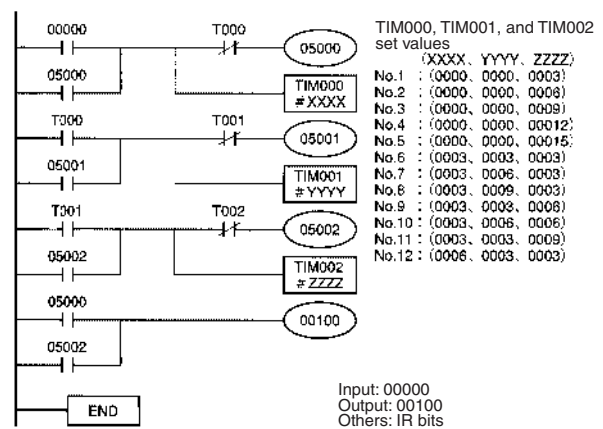

Dimensions

Note: All units are in millimeters unless otherwise indicated.

Mark Sensors

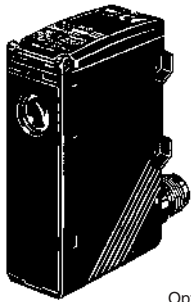

Connector Models

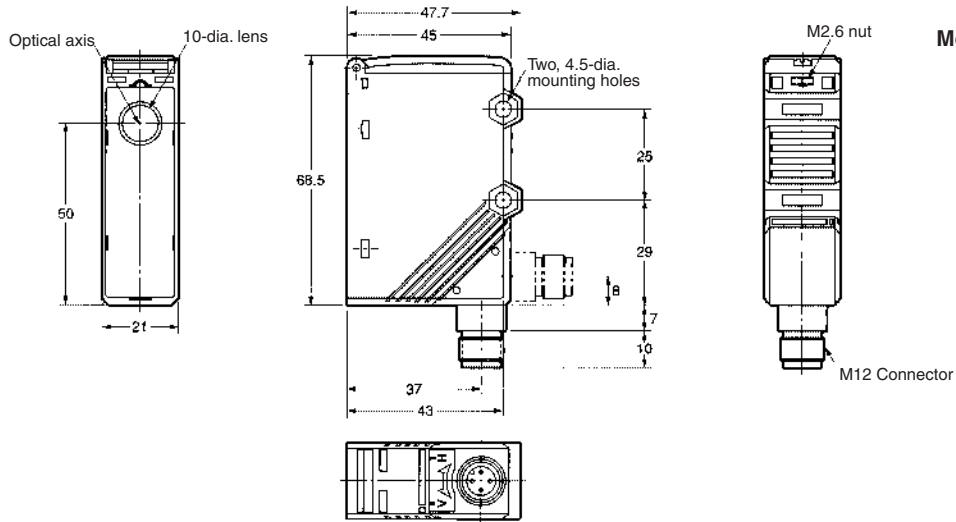
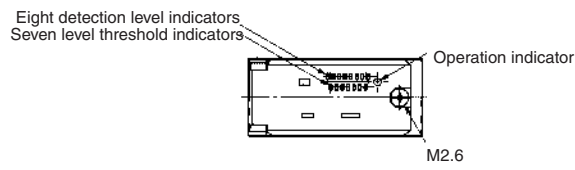

Pre-Wired Models

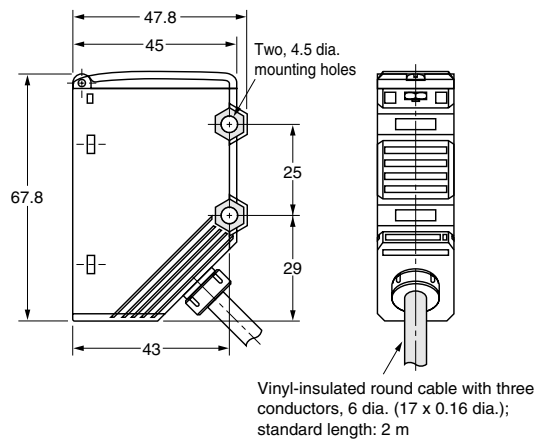

Accessories (Order Separately)

Mounting Brackets

E39-L131

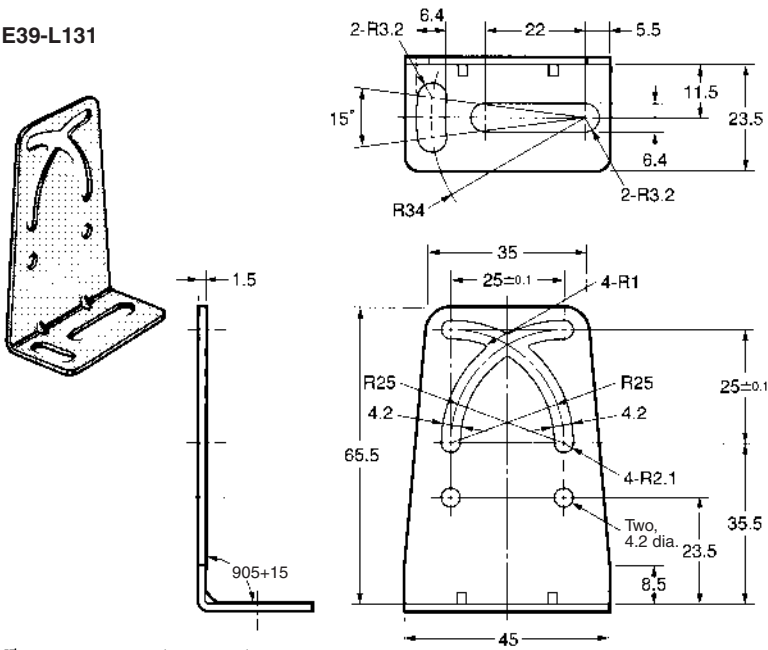

Material: Stainless steel (SUS304)

E39-L132

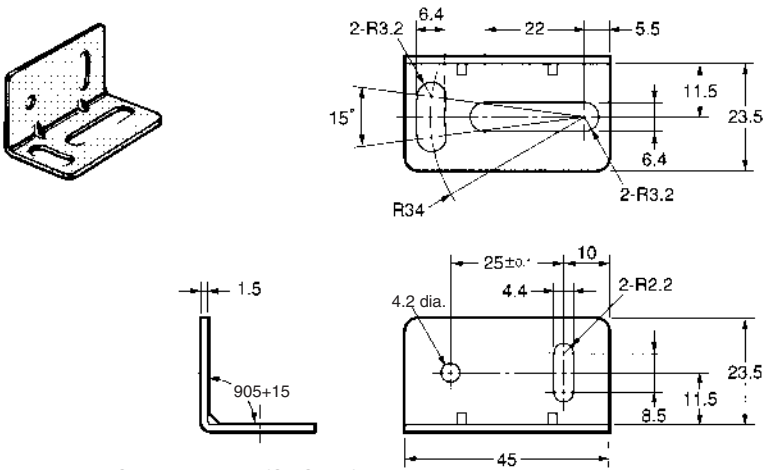

Material: Stainless steel (SUS304)

Sensor I/O Connectors

Single-end Connector (Straight Model)

XS2F-D421-D80-A (L=2 m)
XS2F-D421-G80-A (L=5 m)

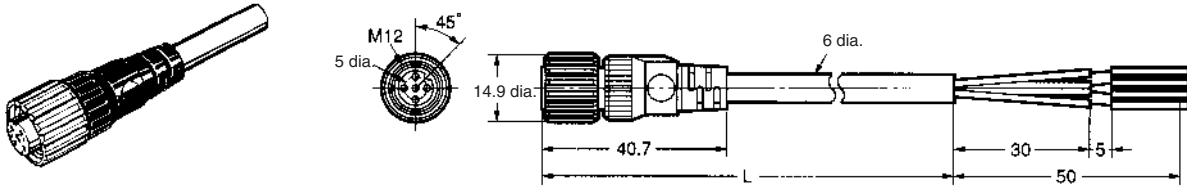

Single-end Connector (L-shaped Model)

XS2F-D422-D80-A (L=2 m)
XS2F-D422-G80-A (L=5 m)

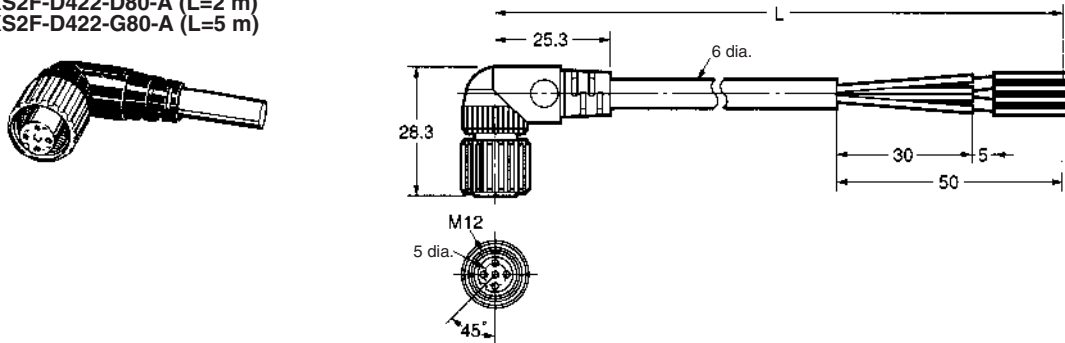

Installation

Sensor I/O Connector

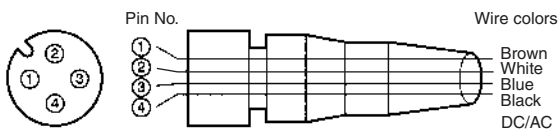

Note: 1. pin No. 2 is not used.
2. For details, refer to the *Sensor I/O Connectors Catalog (X065)*

Classification	Wire color	Connector pin No.	Use
DC	Brown	1	Power supply (+V)
	---	2	---
	Blue	3	Power supply (0V)
	Black	4	Output

Precautions

Observe the following precautions to ensure safety.

- Do not use the Sensor in locations subject to flammable or explosive gases.
- Do not use the Sensor in water or conductive solution.
- Do not disassemble, repair, or modify the Sensor.
- Use the Sensor under proper power supply specifications such as the use of AC or DC power supply.
- Do not apply any voltage or current exceeding the rated level.
- Be careful with the power supply polarities and wire correctly.
- Connect the loads correctly.
- Do not short-circuit both ends of loads.

Correct Use

Installation

Power Reset Time

Since the E3M-V is ready to detect objects from 100 ms max. after the E3M-V is turned ON, operate the remaining devices 100 ms after the Sensor is turned ON. If power is supplied to the E3M-V and the load independently, be sure to turn on the E3M-V first.

Power OFF

The E3M-V may output a single pulse when the control power supply is turned OFF. If the E3M-V is connected to a timer or counter to which power is supplied from an independent power supply, the E3M-V will be more likely to output a single pulse when the control power supply is turned OFF. Therefore, supply power to the timer or counter from the same power supply for the E3M-V.

Power Supply Type

No full-wave or half-wave rectified power supplies can be connected to the E3M-V.

Power Supply Connection

Be sure to ground the FG (frame ground) and G (ground) terminals if a switching regulator is connected to the E3M-V, otherwise the E3M-V may malfunction due to the switching noise of the switching regulator.

Wiring

Cable

The cable can be extended up to 100 m provided that the thickness of the cable is 0.3 mm² minimum.

Repeated Cable Bending

The cable must not be bent repeatedly.

High-tension Lines

The power supply lines of the Sensor must not be wired alongside power lines or high-tension lines in the same conduit, otherwise the Sensor may become damaged or malfunction due to induction noise that may be generated from the power lines or high-tension lines.

Route the lines separately or in a single conduit.

Cable Pulling Force

Do not pull cables with pulling forces exceeding 50N.

Mounting

Screw Tightening

Make sure that the casing is tightened to a maximum torque of 1.2 N o m.

Mounting Direction

When Sensors are mounted to face each other, make sure to adjust the optical axes so that the Sensors will not be mutually interfered.

Others

EEPROM Write Error

An EEPROM error may result if power supply to the Sensor fails or the Sensor is influenced by static noise, in which case the threshold level indicators will flash. Perform the teaching and threshold level setting of the E3M-V again.

M12 Metal Connector

Make sure to connect or disconnect the metal connector after turning off the E3M-V.

Make sure to hold the connector cover when connecting or disconnecting the metal connector.

Tighten the metal connector securely by hand. Do not use any tool, such as pliers, otherwise the metal connector may be damaged.

If the metal connector is not tightened securely, the metal connector may be disconnected by vibration and the proper degree of protection of the E3M-V may not be maintained.

ALL DIMENSIONS SHOWN ARE IN MILLIMETERS.

To convert millimeters into inches, multiply by 0.03937. To convert grams into ounces, multiply by 0.03527.