

### Photoelectric Sensor with Built-in Power Supply and Wiring Terminal Block for Easy Maintenance and Reliable Operation

- Available for both AC and DC, with self-contained timer function
- Easy-to-wire with stepped terminal block system
- Provides polarized beam for reliable detection of shiny object (retroreflective models)
- Relay output and transistor output models (contact output: SPDT)



## Ordering Information

When placing your order, specify the conduit type by adding one of the following suffix codes to the model number as shown below.

-G: PG13.5 (European type)

-US: 1/2-14NPT

Sensing method		Through-beam	Retroreflective	Diffuse reflective	
<b>Sensing distance</b>		10 m	4 m	70 cm	
<b>With timer</b>	<b>Relay output</b>	E3JM-10M4T	E3JM-R4M4T	E3JM-DS70M4T	
	<b>Transistor output</b>	<b>NPN</b>	E3JM-10S4T	E3JM-R4S4T	E3JM-DS70S4T
		<b>PNP</b>	E3JM-10R4T	E3JM-R4R4T	E3JM-DS70R4T
<b>Without timer</b>	<b>Relay output</b>	E3JM-10M4	E3JM-R4M4	E3JM-DS70M4	
	<b>Transistor output</b>	<b>NPN</b>	E3JM-10S4	E3JM-R4S4	E3JM-DS70S4
		<b>PNP</b>	E3JM-10R4	E3JM-R4R4	E3JM-DS70R4

## Specifications

Item	E3JM-10j 4	E3JM-10j 4T	E3JM-R4j 4	E3JM-R4j 4T	E3JM-DS70j 4	E3JM-DS70j 4T
<b>Sensing method</b>	Through-beam		Retroreflective		Diffuse reflective	
<b>Supply voltage</b>	12 to 240 VDC $\pm$ 10%, ripple (p-p): 10% max. 24 to 240 VAC $\pm$ 10%, 50/60 Hz					
<b>Power consumption</b>	3 W max.		2 W max.			
<b>Sensing distance</b>	10 m		4 m (with E39-R1 reflector)		70 cm (20 × 20 white mat paper)	
<b>Sensing object</b>	Opaque 16 mm min.		Opaque 56 mm min.		Opaque and translucent	
<b>Directional angle</b>	3° to 20°		Sensor: 1° to 5° Reflector: 40° min.		---	
<b>Differential travel</b>	---		---		20% max.	
<b>Control output</b>	Relay output: SPDT 250 VAC, 3 A max. ( $\cos\phi = 1$ ) 5 VDC, 10 mA min. Transistor output: 48 VDC, 100 mA max. (residual voltage: 2 V max.)					
<b>Response time</b>	Relay output: 30 ms max. Transistor output: 5 ms max.					
<b>Sensitivity adjustment</b>	Fixed				Adjustable	
<b>Operating mode</b>	Light ON and Dark ON switch selectable					
<b>Indicator</b>	Light indicator (red)	Operation indicator (red)	Light indicator (red)	Operation indicator (red)	Light indicator (red)	Operation indicator (red)
<b>Timer function</b>	ON-delay/OFF-delay/One-shot delay switch selectable Delay time: 0.1 to 5 s (adjustable), only for E3JM-j j j 4T					
<b>Connecting method</b>	Terminal block system					
<b>Enclosure rating</b>	IEC: IP66					
<b>Outer diameter of applicable cable</b>	6 to 8 dia.					
<b>Light source</b>	Infrared LED (950 nm)		Red LED (polarized) (660 nm)		Infrared LED (950 nm)	
<b>Life expectancy</b>	Mechanical: 50,000,000 times min. (switching frequency: 18,000 times/h) Electrical: 100,000 times min. (switching frequency: 1,800 times/h)					
<b>Ambient illumination</b>	Operating: 3,000 lx max. on optical spot (incandescent lamp)					
<b>Ambient temperature</b>	Operating: -25°C to 55°C (with no icing) Storage: -30°C to 70°C					
<b>Ambient humidity</b>	Operating: 45% to 85% Storage: 35% to 95%					
<b>Insulation resistance</b>	20 M $\Omega$ min. (500 VDC)					
<b>Dielectric strength</b>	2,000 VAC, 50/60 Hz for 1 min					
<b>Vibration resistance</b>	Destruction: 10 to 55 Hz, 1.5-mm double amplitude, 2 hrs each in X, Y, and Z directions Malfunction: 10 to 55 Hz, 1.5-mm double amplitude, 2 hrs each in X, Y, and Z directions					
<b>Shock resistance</b>	Destruction: 500 m/s <sup>2</sup> (approx. 50G), 3 times each in X, Y, and Z directions Malfunction: 100 m/s <sup>2</sup> (approx. 10G), 3 times each in X, Y, and Z directions					
<b>Material</b>	Case: ABS Lens: PMMA (Acrylate) Cover: PC (Polycarbonate) Mounting bracket: Steel					
<b>Weight</b>	Approx. 240 g		Approx. 130 g		Approx. 130 g	

# Engineering Data

**Parallel Operating Range (Typical)**  
E3JM-10j 4(T)

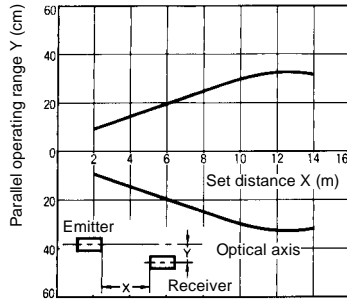

**Parallel Operating Range (Typical)**  
E3JM-10j 4(T) with E39-S39 (Slit)

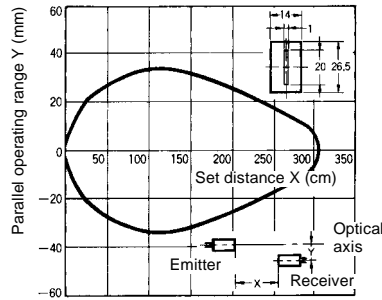

**Retroreflective Parallel Operating Range (Typical)**  
E3JM-R4j 4(T)

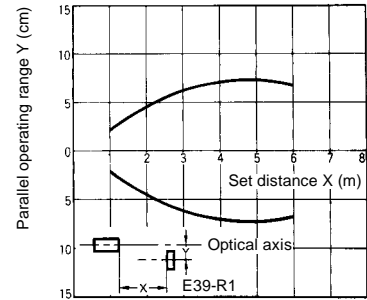

**Surface Color of Sensing Object vs. Operating Range (Typical)**  
E3JM-DS70j 4(T)

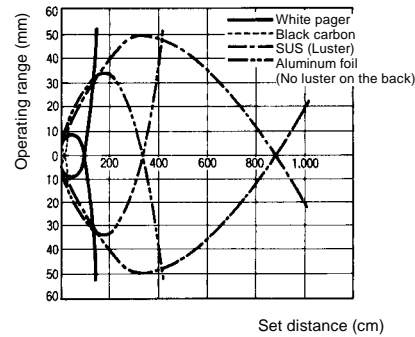

**Size of Sensing Object vs. Sensing Distance (Typical)**  
E3JM-DS70j 4(T)

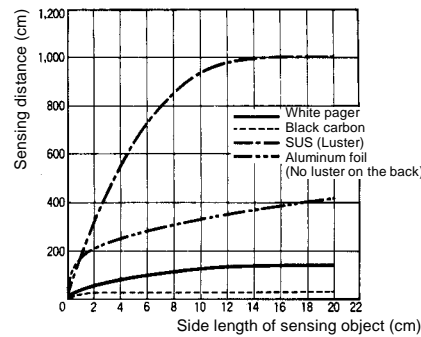

**Excess Gain Ratio vs. Setting Distance (Typical)**  
E3JM-10j 4(T)

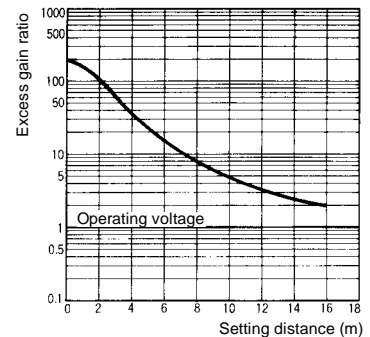

**Excess Gain Ratio vs. Setting Distance (Typical)**  
E3JM-R4j 4(T)  
(When Using E39-R1)

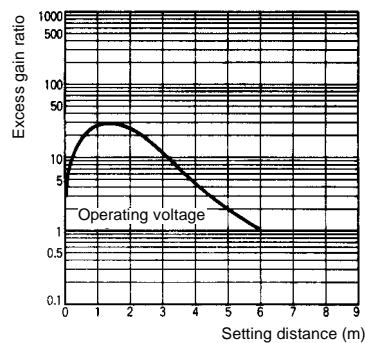

**Excess Gain Ratio vs. Setting Distance (Typical)**  
E3JM-R4j 4(T)  
(When Using E39-R3 or E39-RSB)

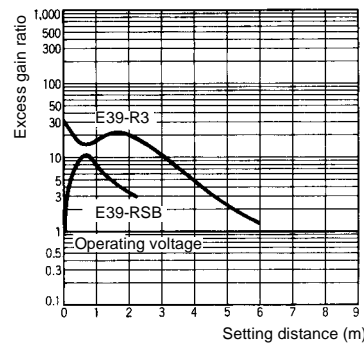

**Excess Gain Ratio vs. Setting Distance (Typical)**  
E3JM-DS70j 4(T)

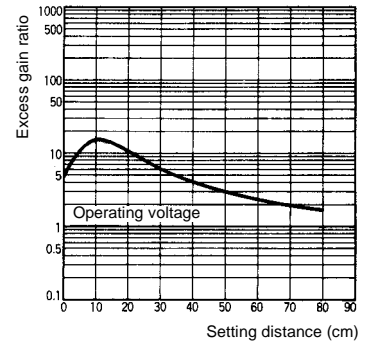

# Operation

## Switch Configuration

### Models Without Timer

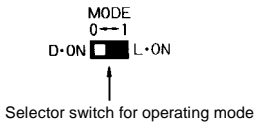

### Models With Timer

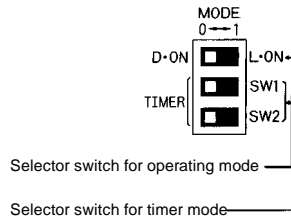

## Switch Selection

### Models Without Timer

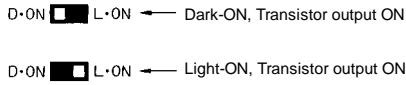

### Models With Timer

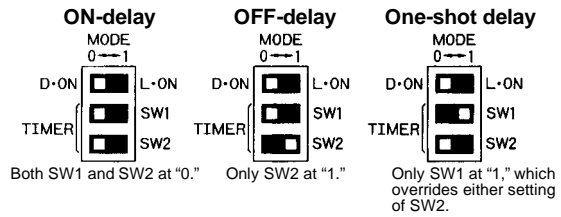

**Note:** Selector switch for operating mode is same as that for models without timer.

## Output Circuit

### Relay Output Models E3JM-j M4(T)

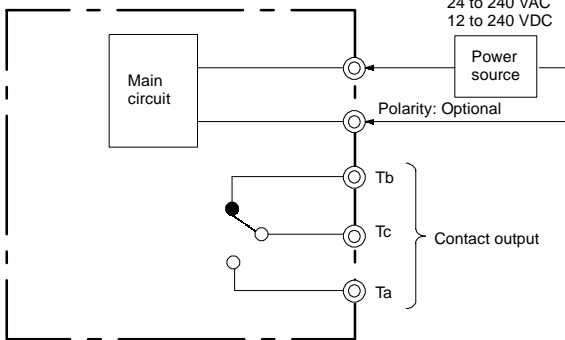

### DC Transistor Output Models E3JM-j S4(T)

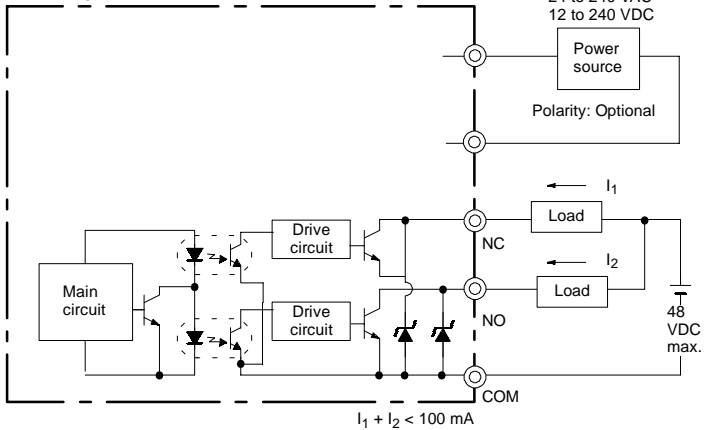

### E3JM-j R4(T)

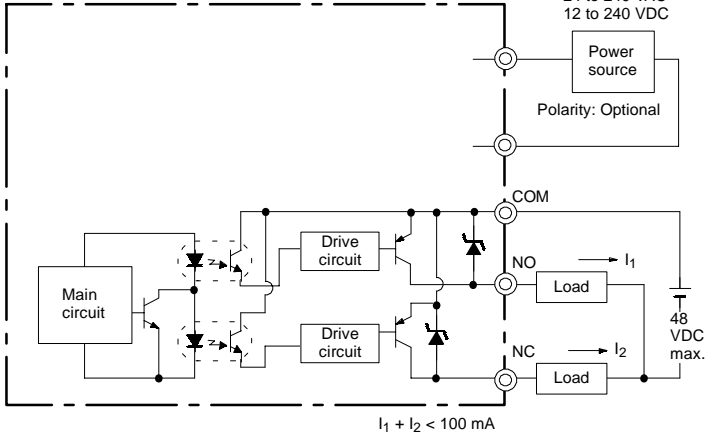

■ Timing Charts

Models Without Timer

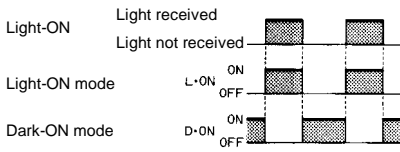

Models With Timer

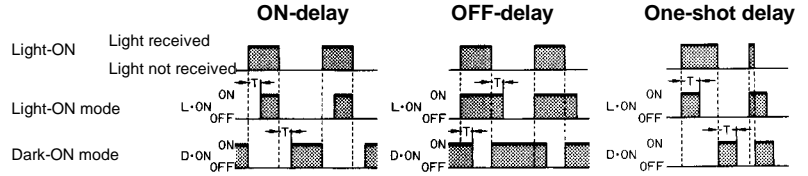

Dimensions

Note: All units are in millimeters unless otherwise indicated.

E3JM-10j 4(T)

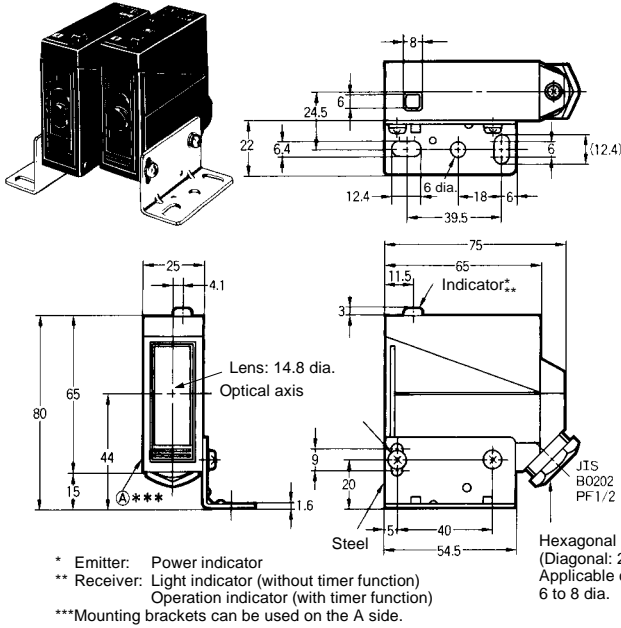

E3JM-DS70j 4(T)  
E3JM-R4j 4(T)

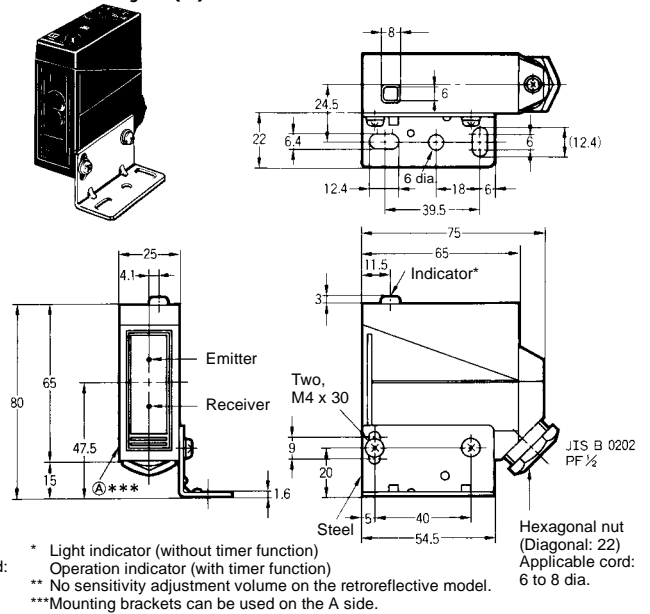

Mounting Holes

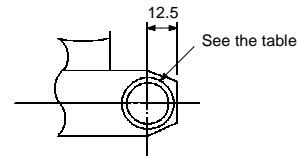
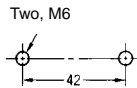

Conduit types	Suffix code
1/2-14NPT	-US
PG 13.5	-G (CENELEC conformed type)

■ Mounting Bracket (Order Separately)

When changing from a conventional model to an E3JM, use the E39-L51 mounting bracket if any optical axis deviation problems occur.

E39-L51

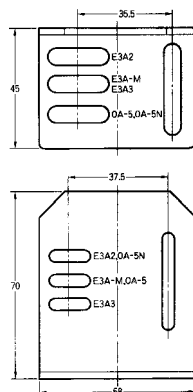
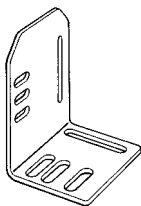

Mounting Example

Shown below is a mounting example for changing from an E3A3 to an E3JM.

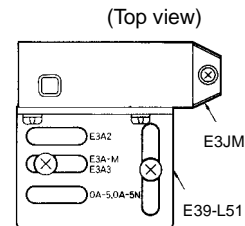

■ Reflectors

**E39-R1 (Included with Retroreflective Models)**

Materials: Reflective side: PMMA (Acrylic resin)  
Back side: ABS resin

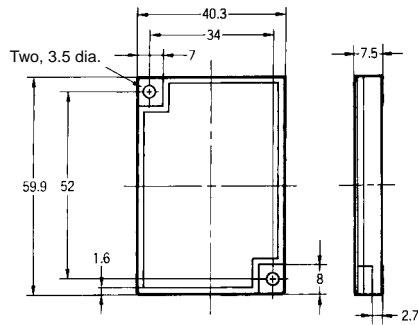
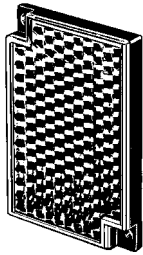

**Compact Type (Order Separately)**

**E39-R3**

Materials: Reflective side: PMMA (Acrylic resin)  
Back side: ABS resin

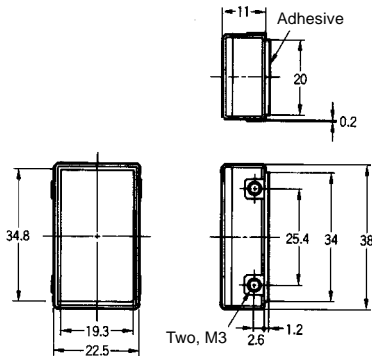
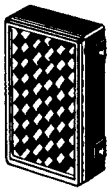

Dimensions with Mounting Bracket

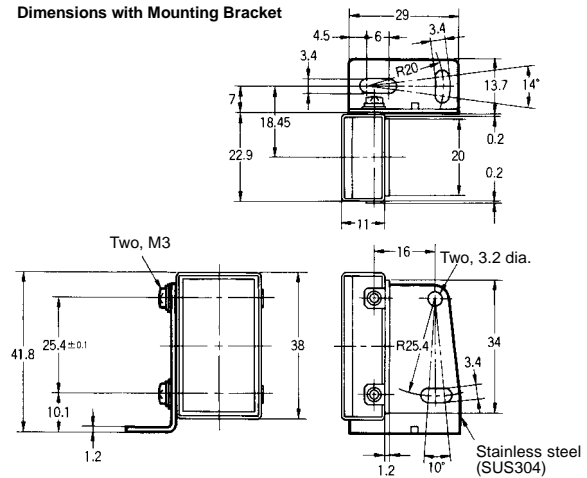

**Tape Type (Order Separately)**

**E39-RSB**

Materials: Vinyl chloride

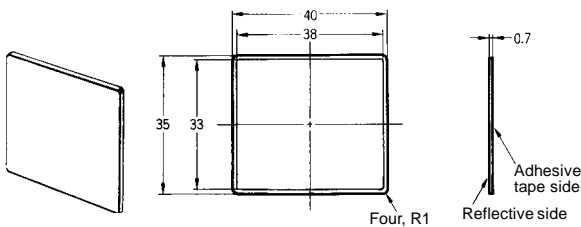

Item	E39-R3	E39-RSB (see note 2)
Sensing distance (with E3JM-R4)	3.5 m	0.25 to 1 m
Directional angle	30° min.	
Ambient temperature	Operating: -25°C to 55°C Storage: -40°C to 70°C	
Ambient humidity	Operating: 35% to 85% Storage: 35% to 95%	
Enclosure rating	IP67	

**Note:** 1. Both models provide the M.S.R. function.  
2. Waterproofing property will be lost if it is cut.

# Installation

## ■ Connections

### Through-beam Models

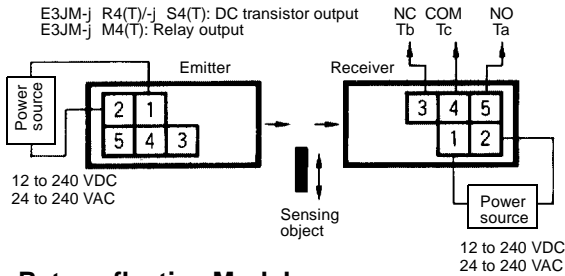

### Retroreflective Models

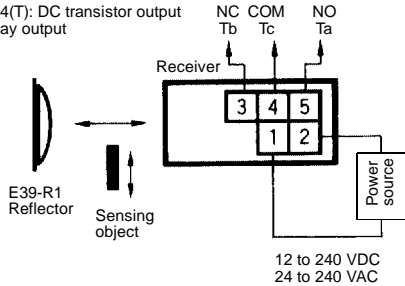

### Diffuse Reflective Models

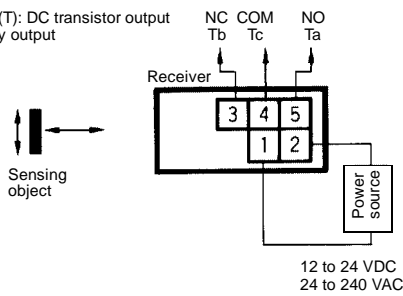

## ■ Adjustment

### Through-beam Models

For a E3JM with the timer function, the indicator will be lit when incident light is received while the mode is switched to L-ON, and the indicator will be lit when light is interrupted while the mode is switched to D-ON.

Move the emitter and receiver horizontally and vertically, and locate them to the center of the range in which the receiver indicator is lit.

### Retroreflective Models

The indicator of the retroreflective model with the timer function is lit in the same way as for the through-beam model.

As with the through-beam model, adjust the reflector and Sensor. Since the directional angle of the E3JM retroreflective model is 1 to 5 degrees, pay careful attention when adjusting the Sensor.

### Diffuse Reflective Models

The indicator of the diffuse reflective model with the timer function is lit in the same way as for the through-beam model.

Sensing object is present.

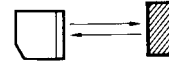

Sensing object is not present.

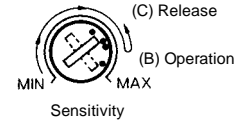
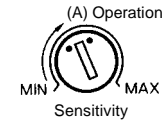
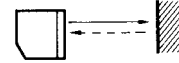

1. If a sensing object is present as shown above, turn the sensitivity adjuster clockwise to increase the sensitivity. Point (A) is where the indicator is lit.
2. Remove the sensing object and turn the adjuster clockwise. Point (B) is where the indicator is lit by background objects.
3. Turn the adjuster counterclockwise to decrease the sensitivity, starting from the point (B). Point (C) is where the indicator is lit.
4. The center point between the point (A) and point (C) is the optimum position. If the indicator is not lit by the background object at the maximum sensitivity, set to the center point between the point (A) and the maximum sensitivity.

**Note:** The sensitivity adjuster may be damaged if an excessive force is applied.

# Precautions

## Connecting and Wiring

Recommended outer diameter of cables is from 6 to 8 dia.

Be sure to firmly tighten the cover in order to maintain waterproof and dustproof properties. The screw size of the conduit socket is as shown in the following table.

Model	Conduit socket thread size
E3JM-j	PF <sup>1</sup> / <sub>2</sub>

## Cord Terminal Treatment

Adjust the four wires to the same length when the Ta output is to be used only. If both the Ta and Tb outputs are to be used, treat them as shown in the following diagram.

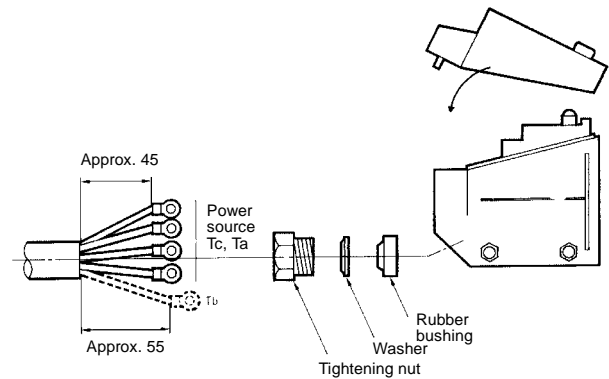

## Recommended Crimp Terminal Dimensions

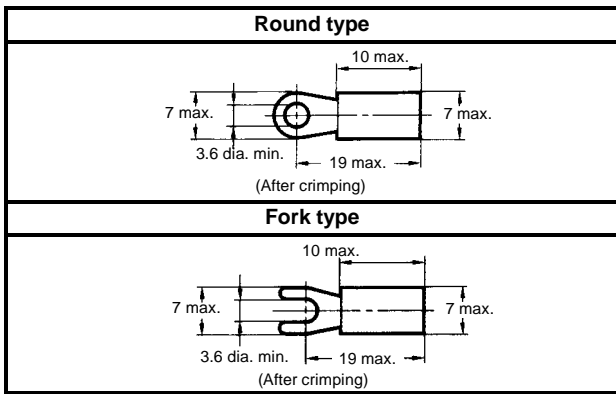

**Note:** Use terminals with insulation tube (recommended crimp terminal: 1.25 to 3.5).

### Terminal Protection Cover (Accessory)

The terminal protection cover is designed to improve safety by maintaining the sensitivity properties of the product and by preventing any contact with charged sections while it is being operated with the mode set to the timer mode. Mount the product as shown in the following diagram (mount the through-beam model on the receiver side).

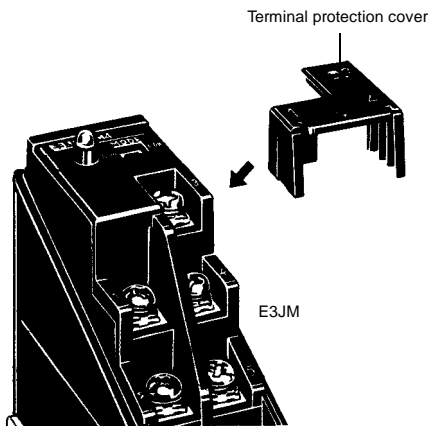

### Output Relay Contact

If a load such as contactor or valve is used that may produce arc when it is turned off, the NC (or NO) side may turn on before the NO (or NC) side is turned off. When using both the NC and NO outputs, use an arc killer.

### Connecting and Wiring DC Transistor Output Models

When using the DC transistor output model, the total of the load current for the L-ON output (NO) and that for the D-ON (NC) should be 100 mA max. If the total exceeds 100 mA, the load short-circuit protection function will be activated (this function will be reset when the power of the photoelectric sensor is turned off).

### Ambient Conditions (Installation Area)

The E3JM will malfunction if installed in the following places.

- Places where the E3JM is exposed to a dusty environment.
- Places where corrosive gases are produced.

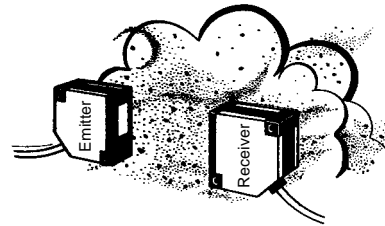

- Places where the E3JM is directly exposed to water, oil, or chemicals.

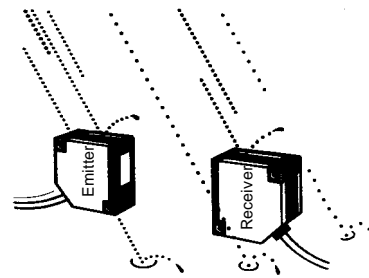

**ALL DIMENSIONS SHOWN ARE IN MILLIMETERS.**

To convert millimeters into inches, multiply by 0.03937. To convert grams into ounces, multiply by 0.03527.

Cat. No. E203-E1-3 In the interest of product improvement, specifications are subject to change without notice.

## OMRON Corporation

Systems Components Division  
28th Fl., Crystal Tower Bldg.  
1-2-27, Shiromi, Chuo-ku,  
Osaka 540 Japan  
Phone: 06-949-6012 Fax: 06-949-6021

Printed in Japan  
0397-1M a