

Safety Relay Unit G9SB

Ultra Slim Safety Relay Unit

- Models of width 17.5 mm available with 2 or 3 safety contacts. Models of width 22.5 mm with 3 safety contacts and auxiliary contact are also available.
- Conforms to EN standards. (TÜV approval)
- DIN track mounting possible.
- Slim size controller dedicated for safety sensors F3SN, F3SH, F3S-B, F3S-TGR, F3SL, F3S-J



Ordering Information

Main contacts	Auxiliary contact	Number of input channels	Reset mode	Input type	Rated voltage	Model	Category (EN954-1)	Size
DPST-NO 2 safety contacts	None	2 channels	Auto-reset	Inverse	24 VAC/VDC	G9SB-2002-A	4	17.5 mm
		1 channel or 2 channels		+ common		G9SB-200-B		
		2 channels	Manual-reset	Inverse		G9SB-2002-C		
		1 channel or 2 channels		+ common		G9SB-200-D		
3PST-NO 3 safety contacts	SPST-NC	None (direct breaking)	Auto-reset	---	24 VDC	G9SB-3010	3	17.5 mm
		2 channels		Inverse	24 VAC/VDC	G9SB-3012-A	4	22.5 mm
		1 channel or 2 channels		+ common		G9SB-301-B		
		2 channels	Manual-reset	Inverse	G9SB-3012-C			
		1 channel or 2 channels		+ common	G9SB-301-D			

Model Number Legend

G9SB-□□□□□□ □
1 2 3 4 5 6

1. Function

None: Emergency stop

2. Contact Configuration (Safety Output)

- 2: DPST-NO
- 3: 3PST-NO

3. Contact Configuration (OFF-delay Output)

0: None

4. Contact Configuration (Auxiliary Output)

- 0: None
- 1: SPST-NC

5. Input Configuration

- None: 1-channel or 2-channel input possible
- 0: None (direct breaking)
- 2: 2-channel input

6. Miscellaneous

- A: Auto-reset, inverse input
- B: Auto-reset, + common input
- C: Manual-reset, inverse input
- D: Manual-reset, + common input

Specifications

Ratings

Power Input

Item	G9SB-200□-□	G9SB-3010	G9SB-301□-□
Power supply voltage	24 VAC/VDC: 24 VAC, 50/60 Hz, or 24VDC 24 VDC: 24 VDC		
Operating voltage range	85% to 110% of rated power supply voltage		
Power consumption	1.4 VA/1.4 W max.	1.7 W max.	1.7 VA/1.7 W max.

Inputs

Item	G9SB-200□-□	G9SB-3010	G9SB-301□-□
Input current	25 mA max.	60 mA max. (See note.)	30 mA max.

Note: Indicates the current between terminals A1 and A2.

Contacts

Item	G9SB-200□-□	G9SB-3010	G9SB-301□-□
	Resistive load (cos ϕ =1)		
Rated load	250 VAC, 5 A		
Rated carry current	5 A		

Characteristics

Item	G9SB-200□-□	G9SB-3010	G9SB-301□-□
Contact resistance (See note 1.)	100 m Ω		
Operating time (See note 2.)	30 ms max.		
Response time (See notes 2 and 3.)	10 ms max.		
Insulation resistance (See note 4.)	100 M Ω min. (at 500 VDC)		
Dielectric strength	Between different outputs	2,500 VAC, 50/60 Hz for 1 min	
	Between inputs and outputs		
	Between power inputs and outputs		
Vibration resistance	10 to 55 to 10 Hz, 0.375-mm single amplitude (0.75-mm double amplitude)		
Shock resistance	Destruction	300 m/s ²	
	Malfunction	100 m/s ²	
Durability	Mechanical	5,000,000 operations min. (at approx. 7,200 operations/hr)	
	Electrical	100,000 operations min. (at approx. 1,800 operations/hr)	
Minimum permissible load (reference value)	5 VDC, 1 mA		
Ambient operating temperature	-25 to 55°C (with no icing or condensation)		
Ambient operating humidity	35% to 85%		
Terminal tightening torque	0.5 N·m		
Weight	Approx. 115 g	Approx. 135 g	Approx. 120 g
Approved standards	EN954-1, EN60204-1, UL508, CSA C22.2 No. 14		
EMC	EMI: EN55011 group 1 class A EMS: EN50082-2		

Note: 1. The contact resistance was measured with 1 A at 5 VDC using the voltage-drop method.

2. The bounce time is not included in the figure for operating time.

3. The response time is the time it takes for the main contact to open after the input is turned OFF.

4. The insulation resistance was measured with 500 VDC at the same places that the dielectric strength was checked.

Application Examples

G9SB-2002-A (24 VAC/VDC) or G9SB-3012-A (24 VAC/VDC) with 2-channel Limit Switch Input/Auto-reset

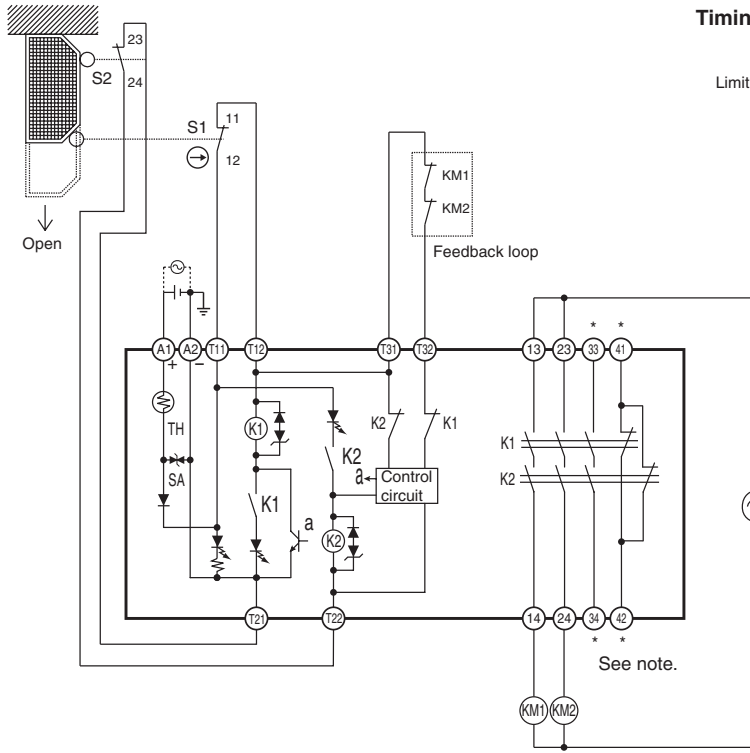

Timing Chart

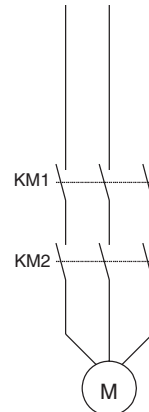
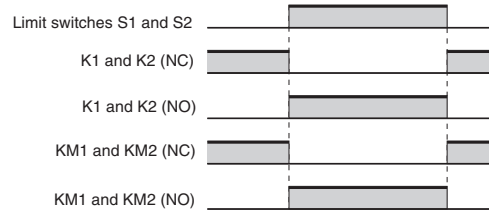

S1: Safety limit switch with direct opening mechanism (D4N or D4B)

S2: Limit switch

KM1 and KM2: Magnetic Contactor

M: 3-phase motor

Note: Only the G9SB-3012-A model has terminals 33-34 and 41-42.

Note: 1. External connections and timing charts for G9SB-200-B/301-B models are the same as those for G9SB-2002-A/3012-A models.
2. This circuit conforms to EN954-1 Safety Category 4.

G9SB-2002-C (24 VAC/VDC) or G9SB-3012-C (24 VAC/VDC) with 2-channel Emergency Stop Switch Input/Manual-reset

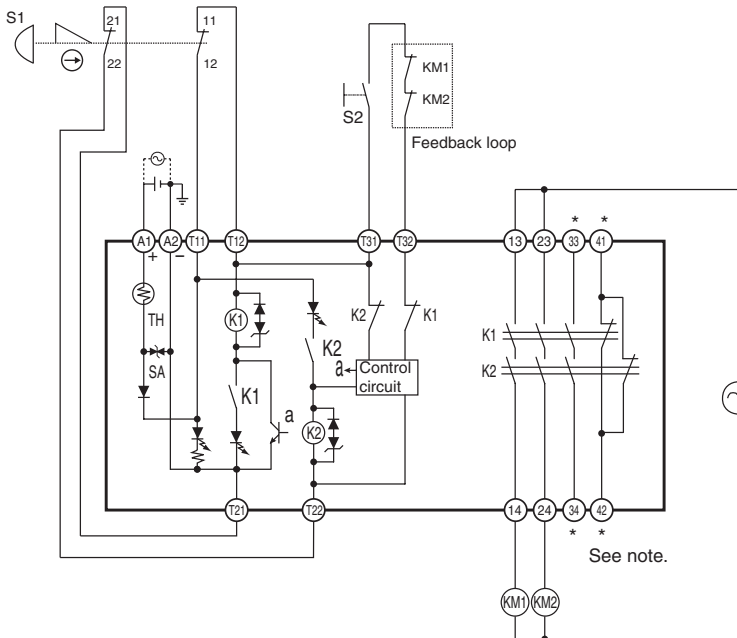

Timing Chart

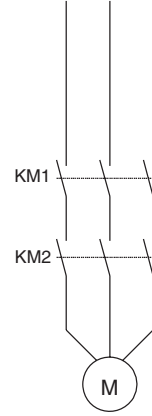
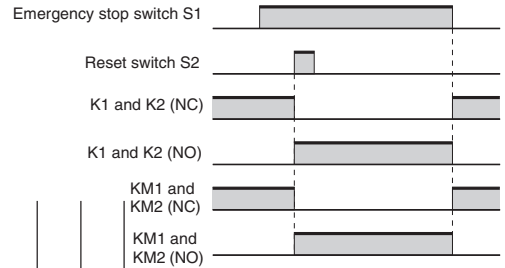

Note: Output turns ON with the rising edge of reset switch S2, but will not operate if there is a short breakdown in S2.

S1: Emergency stop switch with direct opening mechanism (A165E, A22E)

S2: Reset switch

KM1 and KM2: Magnetic Contactor

M: 3-phase motor

Note: Only the G9SB-3012-C model has terminals 33-34 and 41-42.

Note: 1. External connections and timing charts for G9SB-200-D/301-D models are the same as those for G9SB-2002-C/3012-D models.
2. This circuit conforms to EN954-1 Safety Category 4.

G9SB-200-D (24 VAC/VDC) or G9SB-301-D (24 VAC/VDC) with 2-channel Safety Area Sensor/Manual-reset

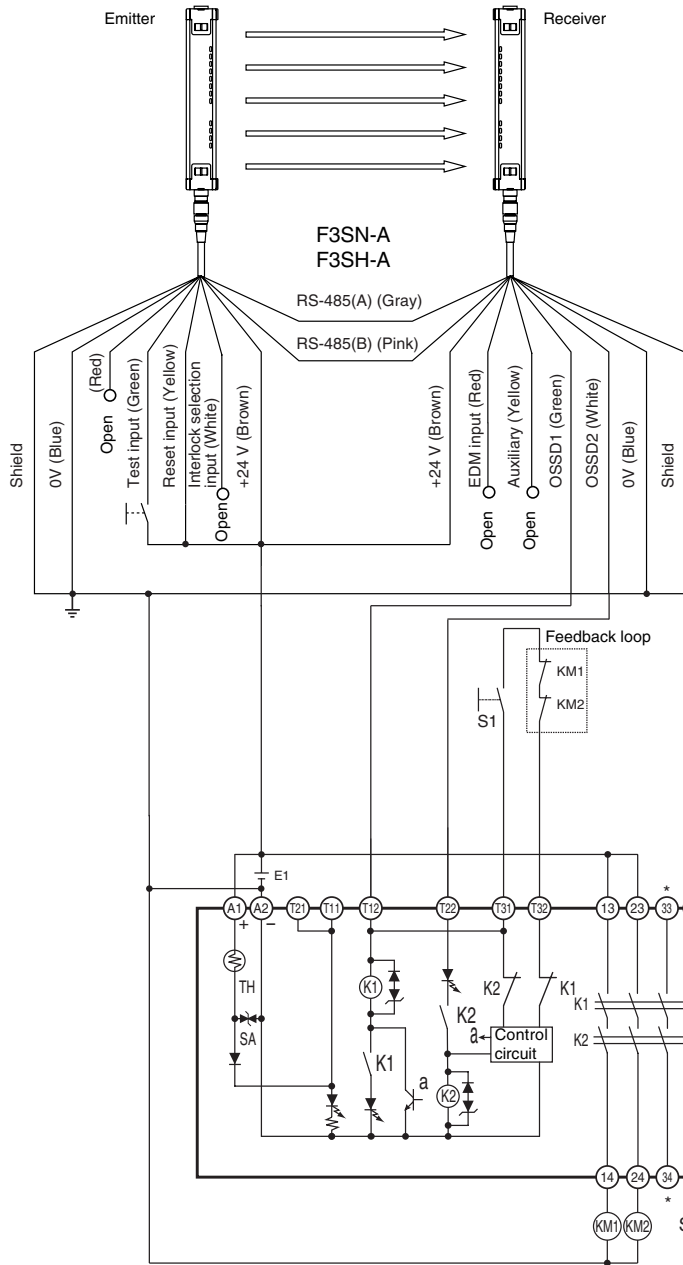

Timing Chart

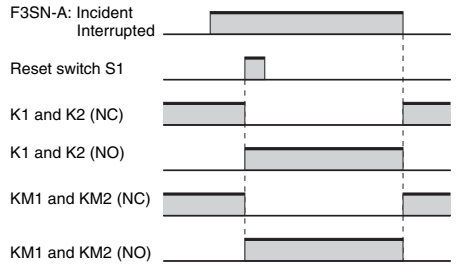

Note: Output turns ON with the rising edge of reset switch S1, but will not operate if there is a short breakdown in S1.

- F3SN-A: Safety Area Sensor
- S1: Reset switch
- KM1 and KM2: Magnetic Contactor
- M: 3-phase motor
- E1: 24-VDC power supply

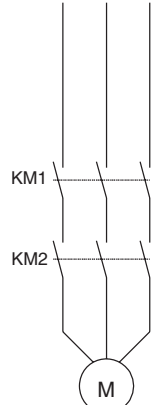

Note: This circuit conforms to EN954-1 Safety Category 4.

G9SB-3010 (24 VDC) with 2-channel Limit Switch Input/Auto-reset

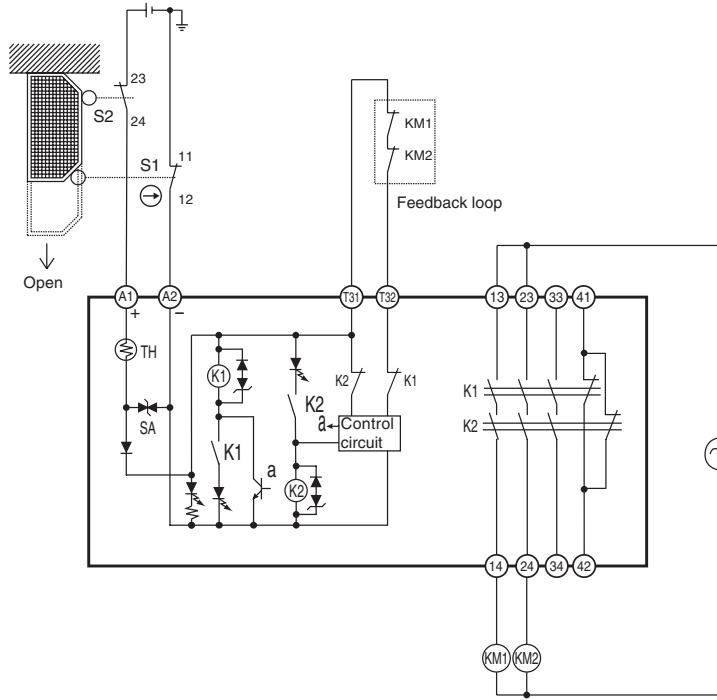

Timing Chart

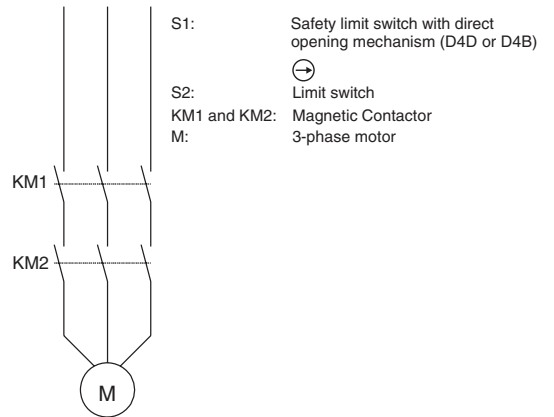
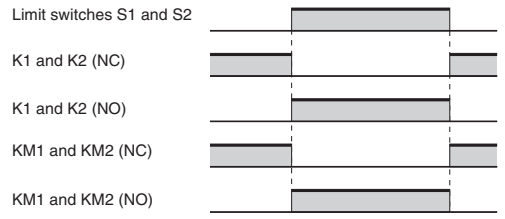

Note: This circuit conforms to EN954-1 Safety Category 3.

Dimensions

G9SB-200□-□
G9SB-3010

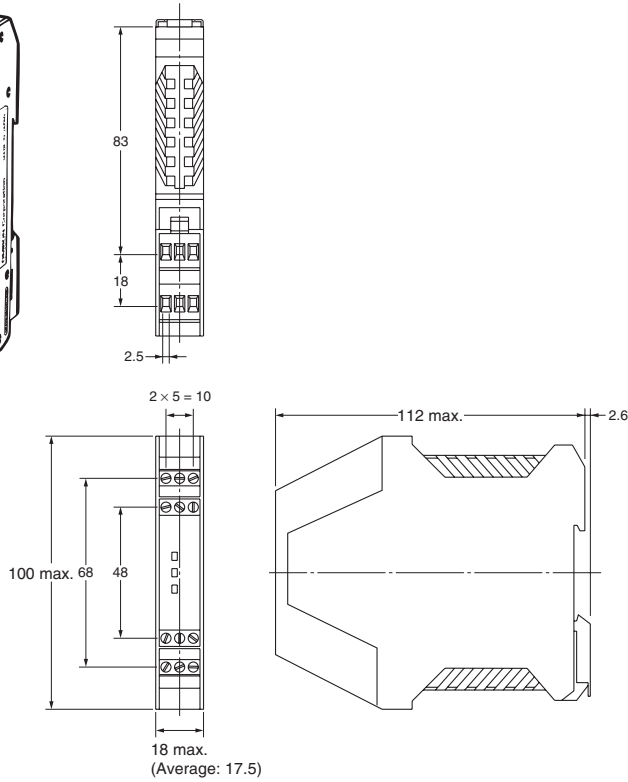
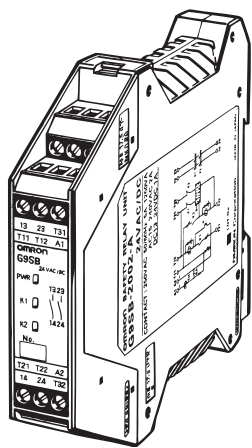

Terminal Arrangement

G9SB-200□-□ G9SB-3010

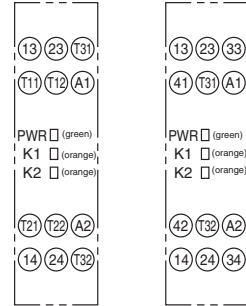

G9SB-301□-□

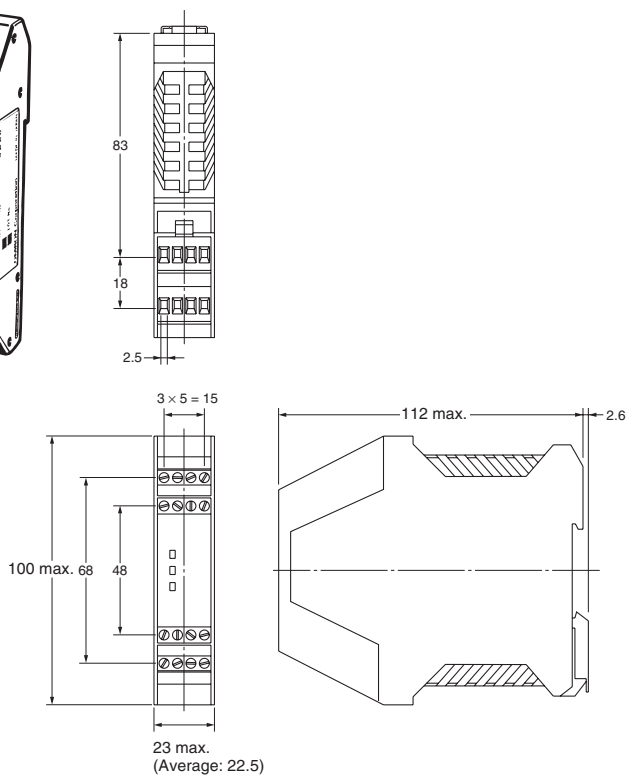
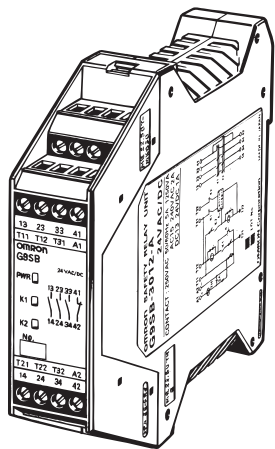

Terminal Arrangement

G9SB-200□-□

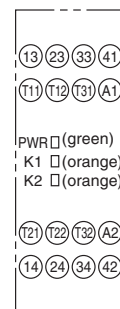

Installation

Internal connections

G9SB-2002-A/C (24 VAC/VDC)

G9SB-3012-A/C (24 VAC/VDC)

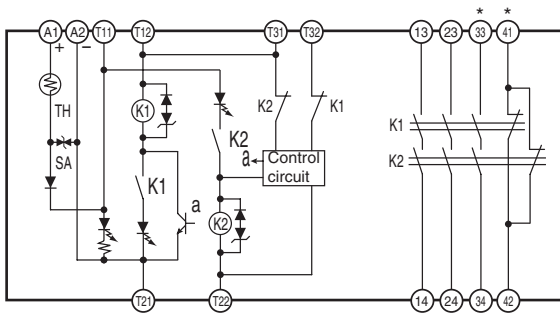

See note 2.

G9SB-200-B/D (24 VAC/VDC)

G9SB-301-B/D (24 VAC/VDC)

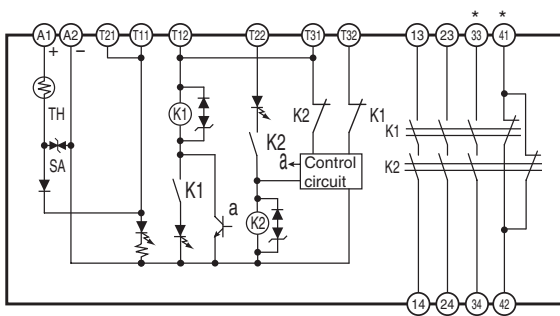

See note 2.

G9SB-3010 (24 VDC)

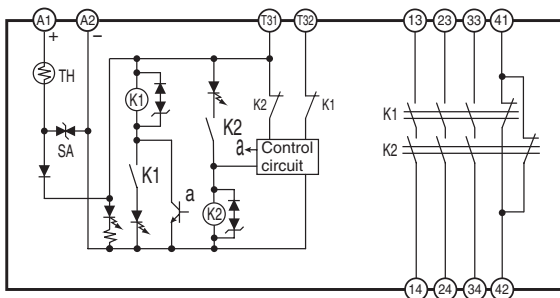

Note: 1. For 1-channel input with G9SB-□□□-B/D models, short terminals T12 and T22.
It is not possible to wire G9SB-□□□2-A/C models for 1-channel input.

2. Only G9SB-301□-□ models have terminals 33-34 and 41-42.

Precautions

Wiring

Turn OFF the G9SB before wiring. Do not touch the terminals of the G9SB while the power is turned ON, because the terminals are charged and may cause an electric shock.

Use the following to wire the G9SB.

Stranded wire: 0.2 to 2.5 mm²

Solid wire: 0.2 to 2.5 mm²

Tighten each screw to a torque of 0.5 to 0.6 N·m, or the G9SB may malfunction or generate heat.

External inputs connected to T11 and T12 or T21 and T22 of the G9SB must be no-voltage contact inputs.

Applicable Safety Category

G9SB-200□-□/301□-□ meet the requirements of Safety Category 4 of the EN954-1 standards when they are used as shown in the examples provided by OMRON. Relays may not meet the standards in some operating conditions. The G9SB-3010 can be applied to Safety Category 3 of the EN954-1 using double breaking. The applicable safety category is determined from the whole safety control system. Make sure that the whole safety control system meets EN954-1 requirements.

Mounting Multiple Units

When mounting multiple Units close to each other, the rated current will be 3 A. Do not apply a current higher than 3 A.

Connecting Inputs

If using multiple G9SB models, inputs cannot be made using the same switch. This is also true for other input terminals.

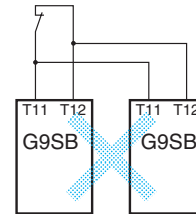

Earth Short

A positive thermistor is built into the G9SB circuits, so you can detect earth short breakdowns and breakdown shorts between channel 1 and channel 2. (Detection of breakdown shorts between channel 1 and channel 2 is supported for G9SB-2002-□/3012-□ models only.)

Note: In order to detect earth short breakdowns, connect the minus side of the power supply to ground.

ALL DIMENSIONS SHOWN ARE IN MILLIMETERS.

To convert millimeters into inches, multiply by 0.03937. To convert grams into ounces, multiply by 0.03527.