

Compact Non-contact Door Switch

D40B

Detects the open/closed state of doors without making contact and has high resistance to the environment.

- Detects the open/closed state of doors without making contact by combining a special magnetic actuator and switch. The switching mechanism is not easily disabled.
- The non-contact operation prevents the creation of particles due to abrasion.
- The actuator and switch can be washed in water. There are no key-holes where dirt can accumulate, making it easy to keep machinery clean.
- Small distortions in the door and mechanical discrepancies can be absorbed in the allowable operating range of the magnetic actuator and switch.
- Conforms to Category 3.



Model Number Structure

Model Number Legend

Sensor

D40B-□□□□
1 2 3 4

1. Type

- 1: Standard Sensor
- 2: Elongated Sensor
- 3: High-temperature Type Sensor

2. Auxiliary Output

- B: None
- D: 1 NC
- E: 1 NO

3. Cable Length

- 3: 3 m
- 5: 5 m
- 10: 10 m

4. Wiring Method

- None: Pre-wired
- C: Connector (switch side only)

Controller

D40B-J□
1

1. Type

- 1: One main contact + one auxiliary contact (See note.)
- 2: Two main contacts + one auxiliary contact (See note.)

Note: The auxiliary contacts use non-safety output.

Ordering Information

List of Models

Sensors (Switches/Actuators)

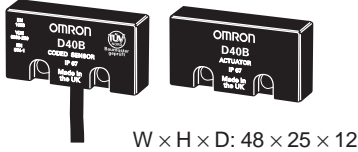
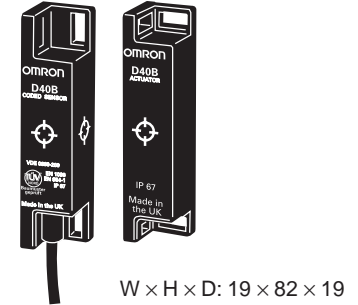
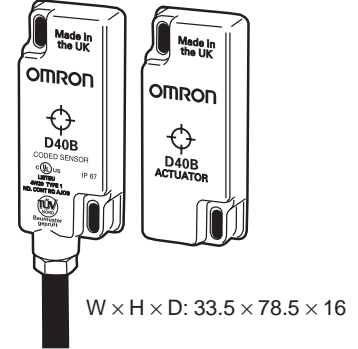
Classification	Shape	Auxiliary output	Cable length	Model
Standard Sensor	 <p>W x H x D: 48 x 25 x 12</p>	None	3 m	D40B-1B3
			10 m	D40B-1B10
		1 NC	3 m	D40B-1D3
			10 m	D40B-1D10
Elongated Sensor	 <p>W x H x D: 19 x 82 x 19</p>	None	3 m	D40B-2B3
			10 m	D40B-2B10
		1 NC	3 m	D40B-2D3
			10 m	D40B-2D10
High-temperature Type Sensor	 <p>W x H x D: 33.5 x 78.5 x 16</p>	1 NC	5 m	D40B-3D5C
		1 NO		D40B-3E5C

Note: A Sensor used in combination with a Controller is classified Category 3.

Controllers

Safety contacts	Auxiliary contacts/output (See note 2.)	Rated voltage	Model
1 NO	1 NC (See note 1.)	24 VAC/VDC	D40B-J1
2 NO	1 NC	24 VAC/VDC 110/230 VAC	D40B-J2

Note: 1. MOS output.
2. Non-safety output.

Accessories

Classification	Model
Fuse	D9M-P1

Specifications

Sensor (Switch/Actuator)

Item	Type	Standard Sensor	Elongated Sensor	High-temperature Type Sensor
Switching distance (See note 1.) (nominal value)		OFF→ON: 5 mm ON→OFF: 15 mm		OFF→ON: 9 mm ON→OFF: 17 mm
Actuator approach speed (See note 2.)		17 mm/s min.		
Operating temperature		-10 to +55°C		-25 to +125°C
Operating humidity		90% at +50°C		
Degree of protection		IP67		
Material		ABS		Stainless steel
Mounting method		M4 screws		
Mounting screw tightening torque		1 N·m		

Note: 1. These values represent the distances at which OFF changes to ON (approaching) or ON changes to OFF (separating) when the switch and actuator's target marks are aligned and the sensing surfaces have the same orientation.

2. If the approach speed is less than the specified value, the Controller's safety contact output may not turn ON, even if the distance is less than the switching distance.

Controller

Ratings

Power Supply

Item	Type	D40B-J1	D40B-J2
Power supply voltage		24 VAC/DC	24 VAC/DC or 110/230 VAC (selectable)
Allowable voltage range		Power supply voltage $\pm 15\%$	
Power consumption		2.0 VA max.	4.0 VA max.

Switch

Item	Type	D40B-J1	D40B-J2
Rated load	Safety contacts	250 VAC, 4 A, $\cos\phi = 1$ 30 VDC, 2 A, $\cos\phi = 1$	
	Auxiliary contacts/output (See note.)	230 VAC, 100 mA, $\cos\phi = 1$ 24 VDC, 100 mA, $\cos\phi = 1$	250 VAC, 4 A, $\cos\phi = 1$ 30 VDC, 2 A, $\cos\phi = 1$

Note: D40B-J1: MOS output; D40B-J2: Contact output.

Characteristics

Item	Type	D40B-J1	D40B-J2
Contact resistance		100 m Ω (not including auxiliary output)	100 m Ω
Auxiliary output ON resistance		36 Ω (nominal value)	---
Response time		25 ms max.	
Insulation resistance		100 M Ω (at 500 VDC)	
Dielectric strength	Between output poles	1,500 VAC 1 min.	
	Between inputs and outputs		
	Between power supply and outputs		
Vibration resistance		10 to 55 Hz, 1-mm single amplitude, IEC68-2-6	
Shock resistance		30G, 11 ms, IEC68-2-27	
Durability	Mechanical	1,000,000 operations min.	
	Electrical	100,000 operation min. (at the rated load)	
Minimum rated current for safety contacts		10 VAC/VDC, 10 mA (reference values)	
Operating temperature		-10 to +55 °C	
Operating humidity		90% at +50 °C.	
Mounting method		35 mm DIN Track (Screw mounting is not possible.)	
Terminal screw tightening torque		1 N·m	
Weight		147 g	590 g

Approved Standards

- EN standards certified by TÜV Nord
EN954-1
EN/IEC60204-1
EN/IEC60947-5-3
- UL508, CSA C22.2 No. 14
- EN1088 conformance

Internal Connection Diagram

D40B-J1

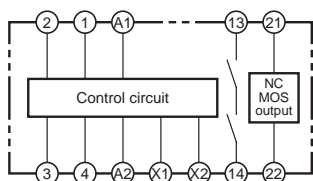

D40B-J2

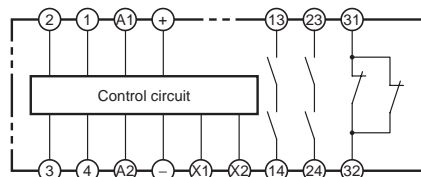

- Note:**
1. If a 100/230 VAC power supply is used, connect it to the A1 and A2 terminals. Do not connect the power supply to the + and – terminals.
 2. If a 24 VDC power supply is used, connect it to the + and – terminals. Do not connect the power supply to the A1 and A2 terminals.

WARNING

Do not connect a 100/230 VAC power supply to the + and – terminals. Doing so may result in electric shock.



Engineering Data

Detection Ranges

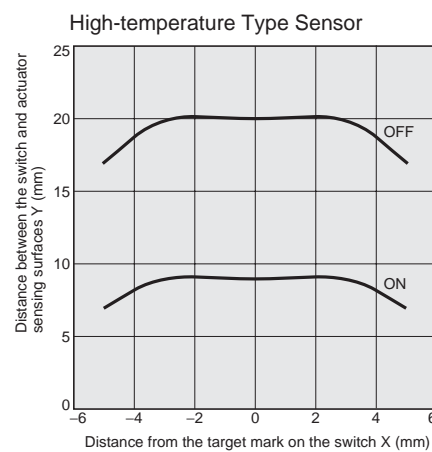
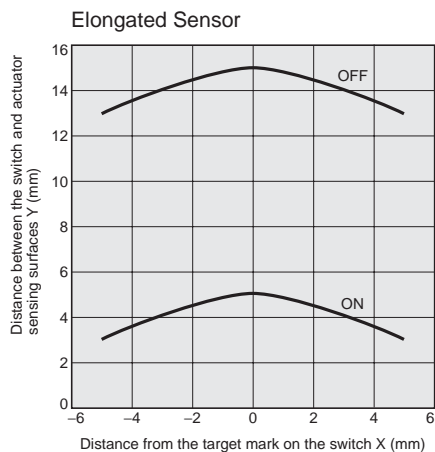
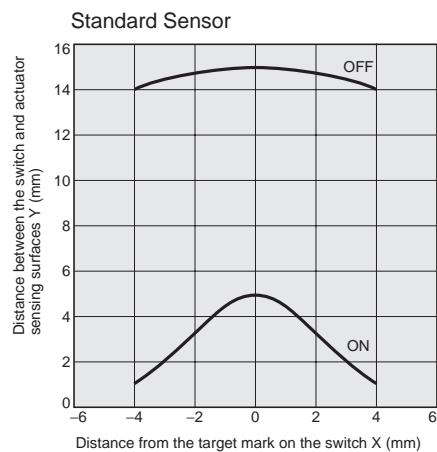

D40B

Dimensions

Note: All units are in millimeters unless otherwise indicated.

Sensor (Switch/Actuator)

Standard Sensor

D40B-1B3
D40B-1B10
D40B-1D3
D40B-1D10

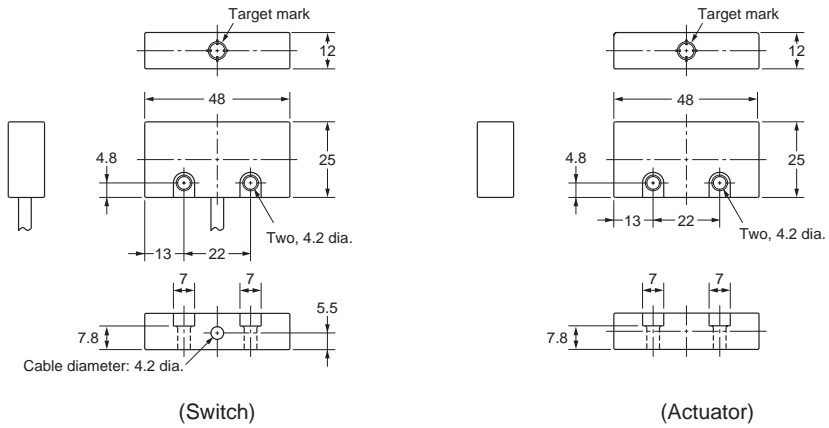
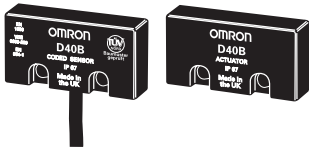

Elongated Sensor

D40B-2B3
D40B-2B10
D40B-2D3
D40B-2D10

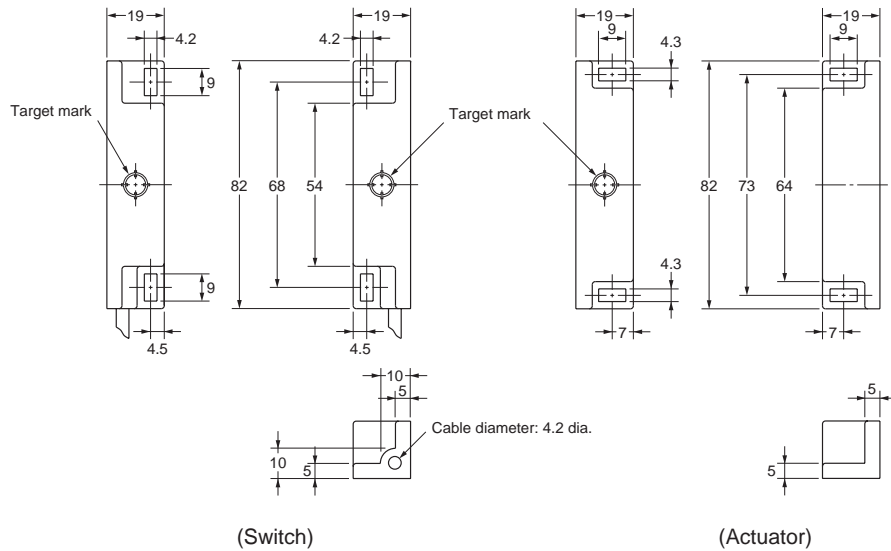

High-temperature Type Sensor

D40B-3D5C
D40B-3E5C

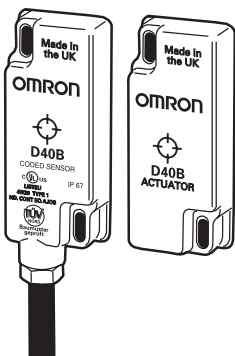

Note: A cable with connectors is included.

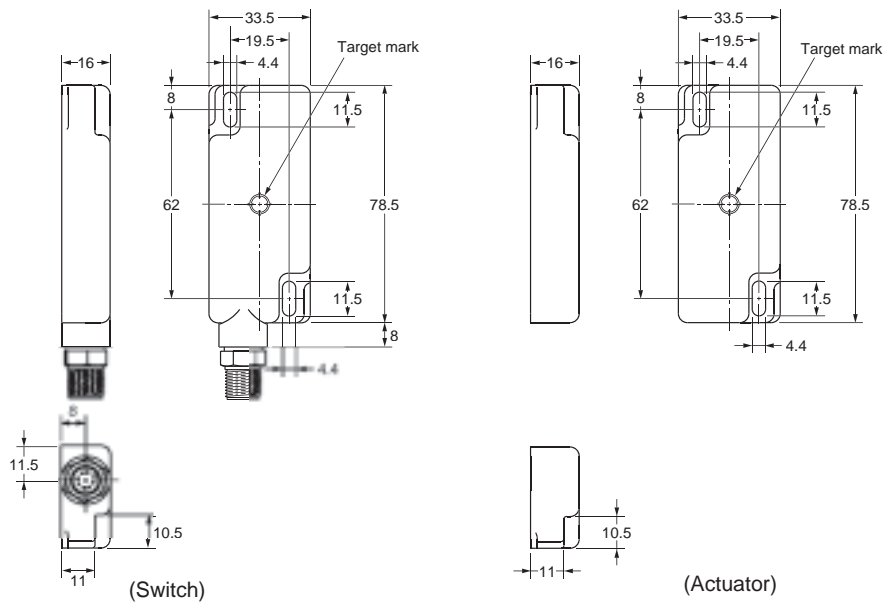

Controller

1-pole Controller

D40B-J1

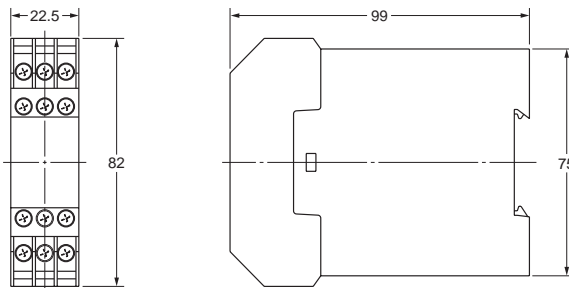
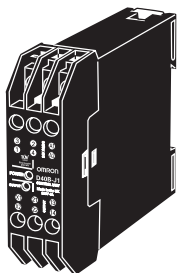

Terminal Arrangement

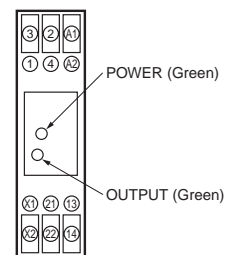

2-pole Controller

D40B-J2

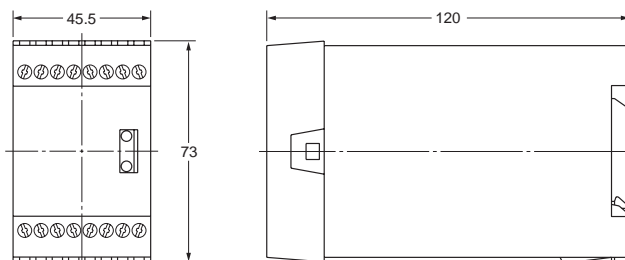
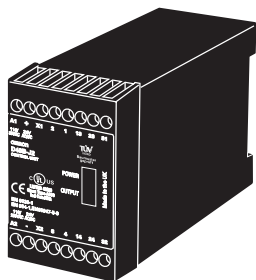

Terminal Arrangement

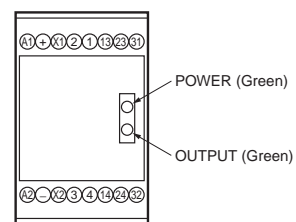

Application Examples

Wiring Example for 1 Sensor and 2 Contactors (with D40B-J1):
Auto-reset

The configuration in this example is for auto-reset and contactor monitoring.

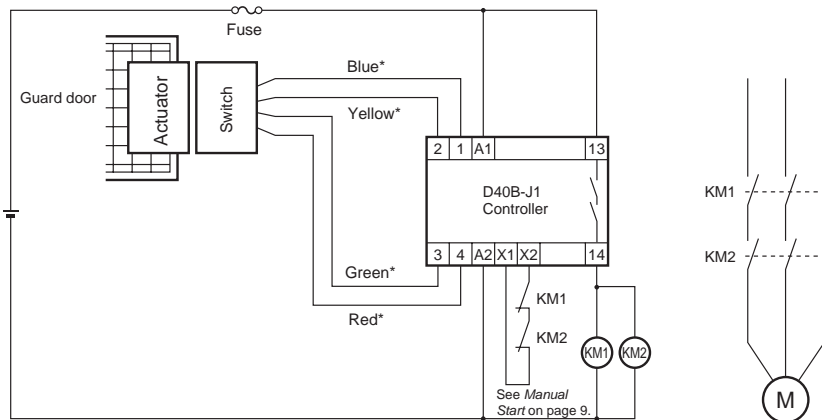

Operation Flowchart



Note: The circuit in this example is equivalent to a Category 3 circuit.

*This example applies to Standard or Elongated Sensors. The wire colors for the High-temperature Type Sensors are different. Refer to *Sensor and Controller Connection Examples* on page 10.

Wiring Example for 1 Sensor and 2 Contactors (with D40B-J2): Auto-reset

The configuration in this example is for auto-reset and contactor monitoring.

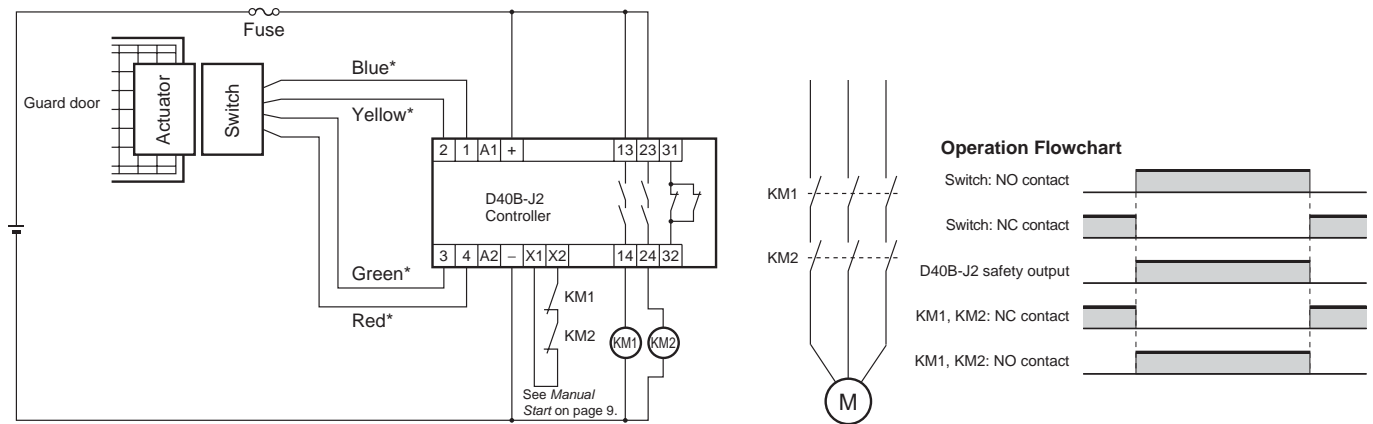

Note: The circuit in this example is equivalent to a Category 3 circuit.

*This example applies to Standard or Elongated Sensors. The wire colors for the High-temperature Type Sensors are different. Refer to *Sensor and Controller Connection Examples* on page 10.

Wiring Example for 3 Sensors and 2 Contactors (with D40B-J2): Auto-reset

The configuration in this example is for auto-reset and contactor monitoring.

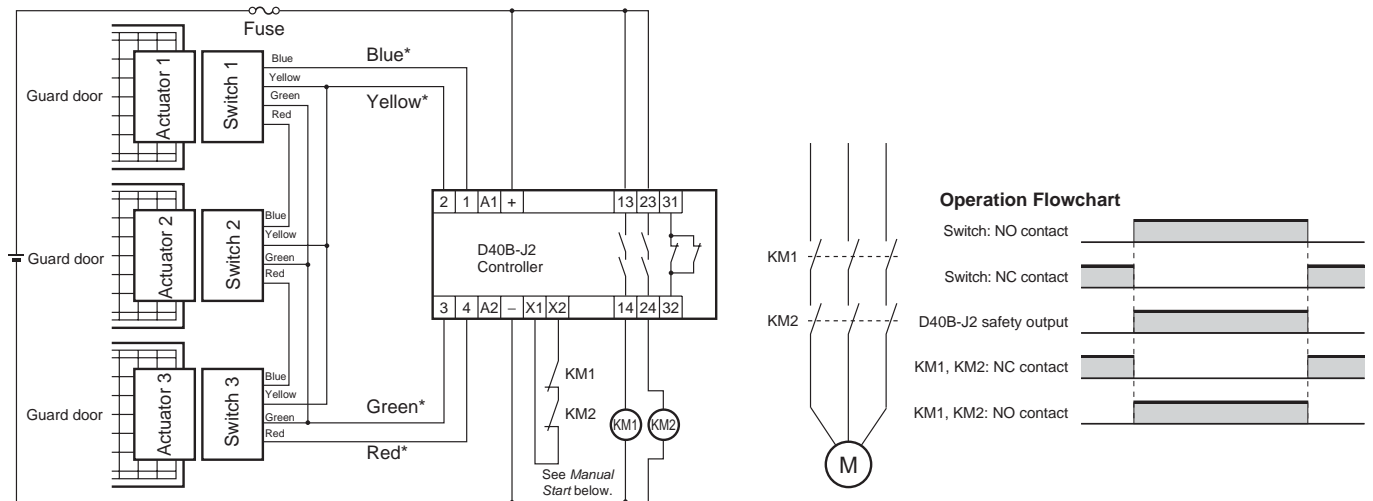

Note 1: The circuit in this example is equivalent to a Category 3 circuit.

Note 2: If two or more Sensors are connected to one Controller, all of the guard doors must open and close independently. If two or more doors open and close at the same time, it is possible that a fault may not be detected.

Note 3: Up to six Sensors can be connected to a single Controller.

*This example applies to Standard or Elongated Sensors. The wire colors for the High-temperature Type Sensors are different. Refer to *Sensor and Controller Connection Examples* on page 10.

Manual Start

If manual start is required, insert start switch S1 between X1 and X2 as shown below. Monitored start is not possible.

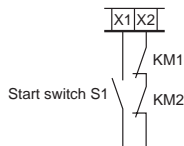

Operation Flowchart

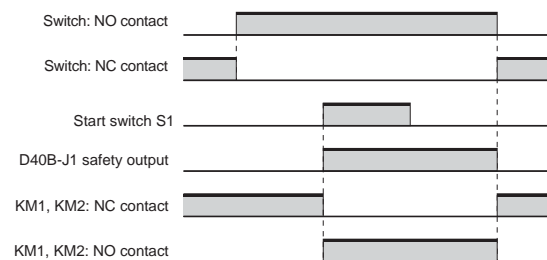

Sensor and Controller Connection Examples

Connection between Standard or Elongated Sensor and 1-pole Controller

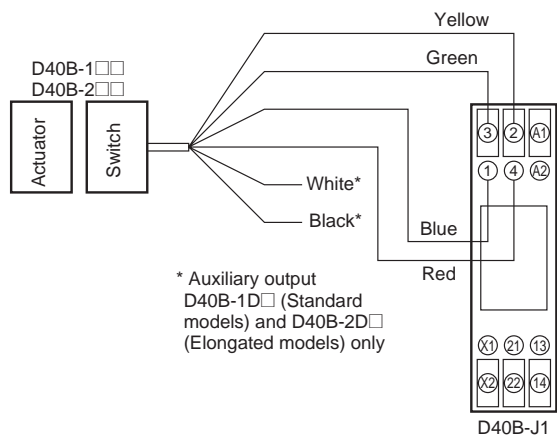

Connection between Standard or Elongated Sensor and 2-pole Controller

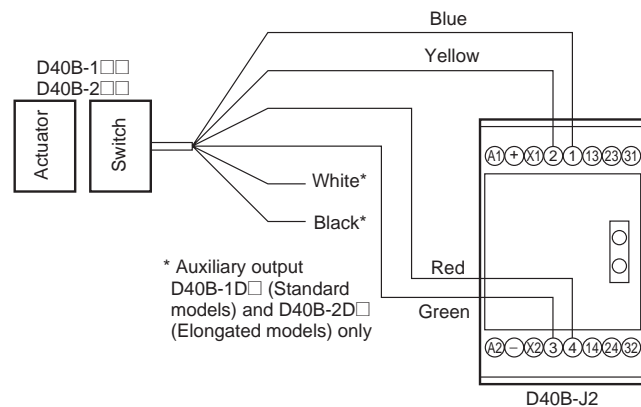

Connection between High-temperature Type Sensor and 1-pole Controller

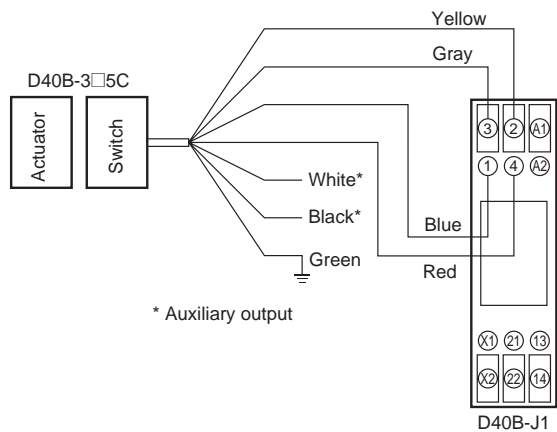

Connection between High-temperature Type Sensor and 2-pole Controller

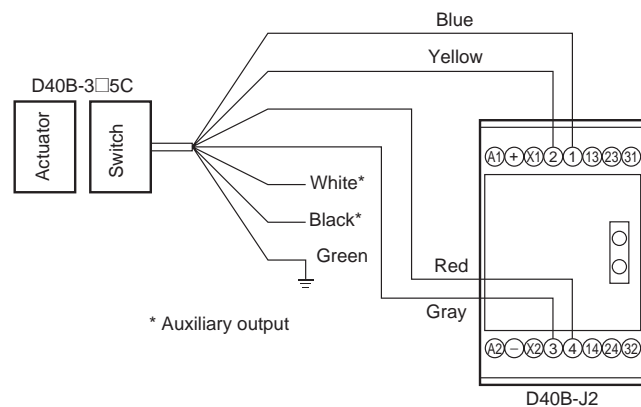

D40B

Safety Precautions

WARNING

Be sure to turn OFF the power before performing wiring. Do not touch charge parts (e.g., terminals) while power is ON. Doing so may result in electric shock.



Do not allow the actuator to come close to the switch with the door open. Doing so may cause machinery to start operating and may result in injury.



CAUTION

Use guard stops in the way shown below to ensure that the switch and actuator do not make contact when the guard door is closed.

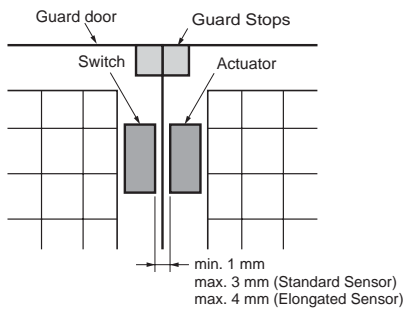

Application Precautions

- Do not use the product in locations subject to explosive or flammable gases.
- Do not use load currents exceeding the rated value.
- Be sure to wire each conductor correctly.
- Be sure to confirm correct operation after completing mounting and adjustment.
- Do not drop or attempt to disassemble the product.
- Be sure to use the correct combination of switch and actuator.
- Use a power supply of the specified voltage. Do not use power supplies with large ripples or power supplies that intermittently generate incorrect voltages.
- Capacitors are consumable and require regular maintenance and inspection.

Precautions for Safe Use

Mounting Direction of Switch and Actuator

The Sensor will not operate properly if the switch and actuator come towards each other diagonally. The Sensor will, however, operate properly if the switch and actuator come towards each other head-on, horizontally or vertically (as long as the faces have the same orientation).

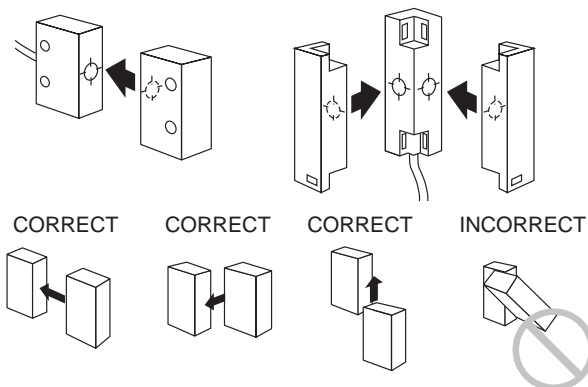

Mutual Interference

If the switch and actuator are mounted in parallel, be sure to separate them by at least 25 mm, as shown below.

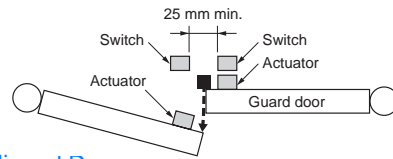

Using for Hinged Doors

On hinged doors, install the Sensor at an opening edge as shown below.

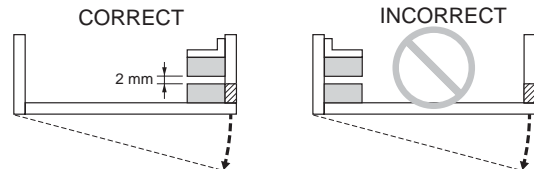

Switching Power Supply Voltage (D40B-J2 Only)

- Turn OFF the power to the Controller.
- Open the Controller's front cover with a flat-bladed screwdriver.
- Change the power supply voltage as required with the internal power supply selection switch. The switch is factory-set to 230 VAC.

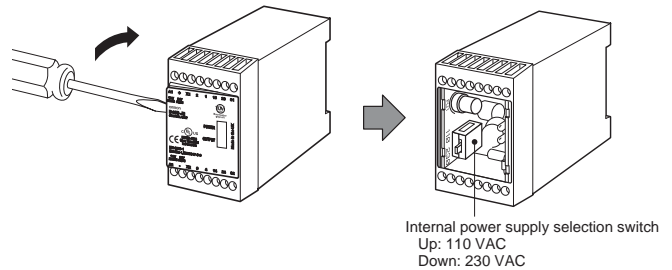

Fuse Replacement Method (D40B-J2 Only)

Note: The D40B-J1 has an automatic recovery mechanism and so fuse replacement is not necessary.

- Turn OFF the power to the Controller.
- Open the Controller's front cover with a flat-bladed screwdriver.
- Replace the fuse (D9M-P1). (See page 213.)

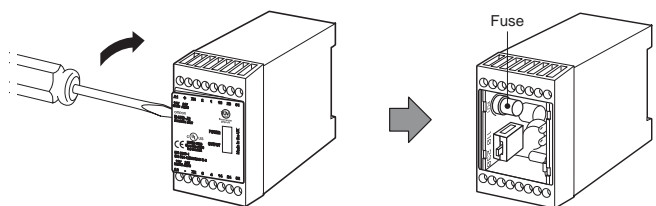

Applicable Safety Category (EN954-1)

This product can be used in environments classified as Safety Category 3 according to the requirements of European standard EN954-1. This evaluation, however, is based on circuit configuration examples proposed by OMRON. The standard may not apply in some operating conditions.

The applicable safety category is determined from the whole safety control system. Make sure that the whole safety control system meets EN954-1 requirements.

Handling

Do not drop the product or subject it to excessive shocks or vibration. Doing so may result in faults or malfunctions.

Solvents

Ensure that solvents, such as alcohol, thinner, trichloroethane, or gasoline do not adhere to the product. Solvents may cause markings to fade and components to deteriorate.

Installation Location

Do not install the product in the following locations. Doing so may result in product failure or malfunction.

- Locations subject to direct sunlight.
- Locations subject to temperatures outside the range 25 to 55 °C.
- Locations subject to humidity levels outside the range 35% to 85% or subject to condensation due to extreme temperature changes.
- Locations subject to corrosive or flammable gases.
- Locations subject to shocks or vibration in excess of the product ratings.
- Locations subject to exposure to water, oil, or chemicals.
- Locations subject to dust (including iron dust) or salts.

Take appropriate and sufficient countermeasures when using the product in the following locations.

- Locations subject to static electricity or other forms of noise.
- Locations subject to possible exposure to radioactivity.
- Locations close to power supply lines.

Wiring

Perform wiring using wire with the following dimensions.

Stranded wire: 2.5 mm²

Solid wire: 4.0 mm²

Tighten the terminal screws with the specified torque. Not doing so may result in malfunction or abnormal heat generation.

Terminal screw tightening torque: 1 N·m