

Multi-channel Power Controller G3ZA

Optimum Cycle Control for High-precision Control with Low Noise

- Smaller than a Normal Power Controller.
- Enables low-noise power control in combination with zero-cross SSRs.
- One Controller can control up to 8 SSRs.
- RS-485 communications to set manipulated variables and heater burnout detection.
- CE Marking

Note: Refer to *Precautions* on page 7 for safety information.



NEW

Features

Comparison between the G3ZA and Normal Power Controllers

Item	Normal Power Controllers	G3ZA
Connections	<p>8-channel Analog Output Unit Programmable Controller 4 to 20 mA commands Power controller Power controller Power controller Power controller 8 total</p>	<p>Serial Communications Unit (RS-485) Programmable Controller RS-485 commands G3ZA-8 Multi-channel Power Controller SSR SSR SSR SSR 8 total</p>
Control method	<p>Phase Control</p> <ul style="list-style-type: none"> • Response is fast and high-precision temperature control is possible. • Harmonics and noise are problems. 	<p>Optimum Cycle Control (High-precision Zero Cross Control)</p> <ul style="list-style-type: none"> • Outputs are turned ON and OFF each half cycle. • Zero-cross control is performed. • Noise is suppressed while achieving high-speed response with high-precision temperature control.

Model Number Structure

Model Number Legend

G3ZA- □ □ □ □ □ - □ - □
 1 2 3 4 5 6 7

No.	Meaning	Code	Specifications
1	No. of control points	4	4 channels
		8	8 channels
2	Control method	None	Optimum cycle control
3	Current transformer input	H	Yes
		A	None

No.	Meaning	Code	Specifications
4	Load power supply voltage	2	100 to 240 VAC
		4	400 to 480 VAC
5	Communications specifications	03	RS-485
6	Communications protocol	FLK	CompoWay/F
7	International standards	UTU	Approved by TÜV/UL/CSA.

Ordering Information

List of Models

Name	Number of control channels	Heater burnout detection	Load power supply voltage	Model
Multi-channel Power Controller	4	Supported	100 to 240 VAC	G3ZA-4H203-FLK-UTU
			400 to 480 VAC	G3ZA-4H403-FLK-UTU
	8	Not supported	100 to 240 VAC	G3ZA-8A203-FLK-UTU
			400 to 480 VAC	G3ZA-8A403-FLK-UTU

Note: When using the heater burnout detection function, CTs must be ordered separately.

Accessories (Order Separately)

Name	Hole diameter	Model
Current Transformer (CT)	5.8 dia.	E54-CT1
	12.0 dia.	E54-CT3

Name	Model
DIN Track	PFP-100N
	PFP-50N
End Plates (stoppers)	PFP-M

Specifications

Ratings

Item	Load power supply voltage range	100 to 240 VAC	400 to 480 VAC
Power supply voltage		100 to 240 VAC (50/60 Hz)	
Operating voltage range		85 to 264 VAC	
Power consumption		16 VA max.	
Load power supply voltage		100 to 240 VAC	400 to 480 VAC
Load power supply voltage range		75 to 264 VAC	340 to 528 VAC
Manipulated variable input		0.0% to 100.0% (via RS-485 communications)	
Current transformer input (See note.)		Single-phase AC, 0 to 50 A (primary current of CT)	
Trigger output		One voltage output for each channel, 12 VDC ±15%, Max. load current: 21 mA (with built-in short-circuit protection circuit)	
Alarm output		NPN open collector, one output Max. applicable voltage: 30 VDC, Max. load current: 50 mA Residual voltage: 1.5 V max., Leakage current: 0.4 mA max.	
Indications		LED indicators	
Ambient operating temperature		-10 to 55°C (with no icing or condensation)	
Ambient operating humidity		25% to 85%	
Storage temperature		-25 to 65°C (with no icing or condensation)	
Elevation		2,000 m max.	
Accessories		Instruction Sheet	

Note: CT inputs are provided only on Models with heater burnout detection.

■ Performance

Current indication accuracy	±3 A (for Models with heater burnout detection)
Insulation resistance	100 MΩ min. (at 500 VDC) between primary and secondary
Dielectric strength	2,000 VAC, 50/60 Hz for 1 min between primary and secondary
Vibration resistance	Vibration frequency: 10 to 55 Hz, acceleration: 50 m/s ² in X, Y, and Z directions
Shock resistance	300 m/s ² three times each in six directions along three axes
Weight	Approx. 200 g (including terminal cover)
Degree of protection	IP20
Memory protection	EEPROM (non-volatile memory) (number of writes: 100,000)
Installation environment	Overvoltage category III, pollution degree 2 (according to IEC 60664-1)
Approved standards	UL508 (Listing), CSA22.2 No. 14 EN50178 EN61000-6-4 (EN55011: 1998, A1: 1999 Class A, Group 1) EN61000-6-2: 2001

■ Communications Specifications

Transmission line connections	Multipoint
Communications method	RS-485
Max. transmission distance	500 m
No. of nodes	31 (via multidrop connections)
Synchronization method	Stop-start synchronization
Communications baud rate	9.6, 19.2, 38.4 or 57.6 kbps, Default: 9.6 kbps
Transmission code	ASCII
Communications data length	7 or 8 bits, Default: 7
Communications stop bits	1 or 2 bits, Default: 2
Communications parity	Vertical parity: None, even, or odd, Default: Even
Flow control	None

■ Current Transformer Specifications (Order Separately)

Item	Specification	
Model number	E54-CT1	E54-CT3
Max. continuous heater current	50 A	120 A (See note.)
Dielectric strength	1,000 VAC for 1 min	
Vibration resistance	98 m/s ² , 50 Hz	
Weight	Approx. 11.5 g	Approx. 50 g
Accessories	None	Connection terminals (2) Plugs (2)

Note: The maximum continuous current of the G3ZA is 50 A.

Optimum Cycle Control

- Optimum cycle control is performed by driving SSRs according to load power detection and trigger signals. (Zero-cross SSRs are used.)
- Noise is suppressed while ensure high-speed response by turning outputs ON and OFF each half cycle to achieve high-precision temperature control.

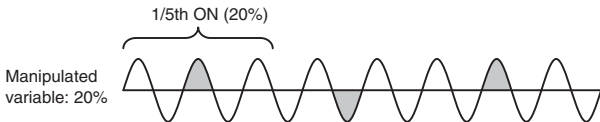

Connections

Terminal Arrangement

**Models with 8 Channels (Control Points),
No CT Inputs, and No Heater Burnout Detection**

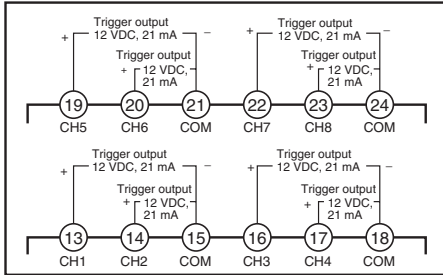

**Models with 4 Channels (Control Points),
CT Inputs, and Heater Burnout Detection**

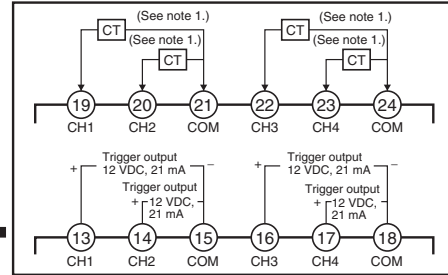

**Models with Load Power Supply Voltage
of 100 to 240 V**

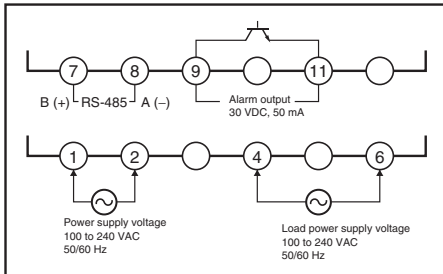

Note: Connect the power supply (100 to 240 VAC) for the G3ZA across terminals 1 and 2 and the load power supply for the SSR loads across terminals 4 and 6.

**Models with Load Power
Supply Voltage of 400 to 480 V**

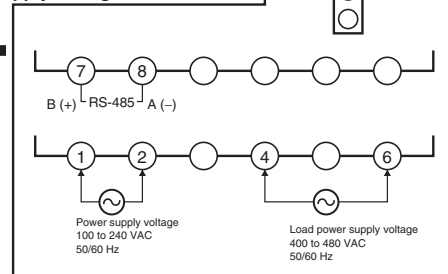

Note: Connect the power supply (100 to 240 VAC) for the G3ZA across terminals 1 and 2 and the load power supply for the SSR loads across terminals 4 and 6.

READY
SD/RD
OCC

ERROR

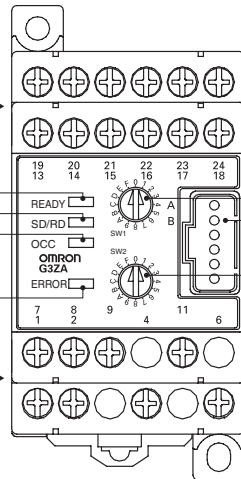

SW1
Alarm output connector (See note 2.)
(only models with load power supply
voltage of 400 to 480 V)

SW2
Alarm output connector (See note 2.)
(only models with load power supply
voltage of 400 to 480 V)

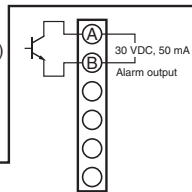

- Note:** 1. Applicable CTs: E54-CT1 and E54-CT3
2. Use C-Grid SL connectors from Molex Inc.

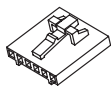

C-Grid SL Housing
Model: 51030-6303

C-Grid SL Housing (press-fit)
Model: 52109-0660

Operation Indicators

Operation indicator	Meaning
READY (Green)	Lit while power is being supplied.
SD/RD (Orange)	Lit while communicating with the host.
OCC (Orange)	Lit while a control output is ON.
ERROR (Red)	Lights or flashes when an error is detected.

Setting Switches

- Always turn OFF the power supply before setting the switches. The switch settings are read only when the power supply is turned ON.
- Use a flat-blade screwdriver to set the switches and be sure not to leave a switch set between two settings.



Communications Unit Number

Set a communications unit number on SW1 so that the host system can identify the Controller.

SW1	0	1	2	3	4	5	6	7	8	9	A	B	C	D	E	F
Unit No.	00	01	02	03	04	05	06	07	08	09	10	11	12	13	14	15

▲
Default

Note: A unique unit number must be set for each node (Controller) on the same communications line. Do not set the same unit number for more than one node.

Communications Baud Rate

Set the baud rate for communicating with the host system on SW2.

SW2	0	1	2	3	4 to F
Baud rate	9.6	19.2	38.4	57.6	Do not set.

▲
Default

■ Connection Configuration

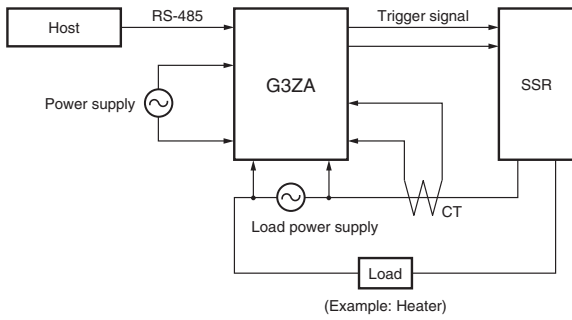

Note: Connect a power supply with the same phase as the SSRs to the load power supply terminals on the G3ZA.

Dimensions

Note: All units are in millimeters unless otherwise indicated.

■ Multi-channel Power Controllers

G3ZA-4H203-FLK-UTU
 G3ZA-4H403-FLK-UTU
 G3ZA-8A203-FLK-UTU
 G3ZA-8A403-FLK-UTU

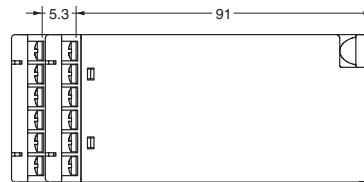
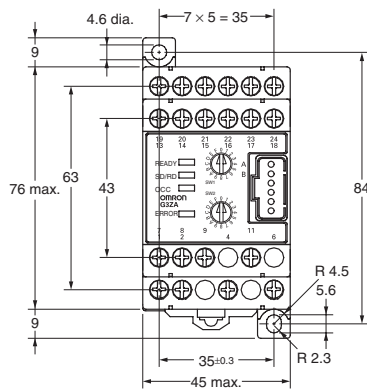
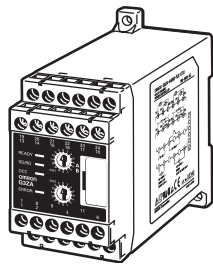

**Mounting Hole Dimensions
 (For Direct Mounting)**

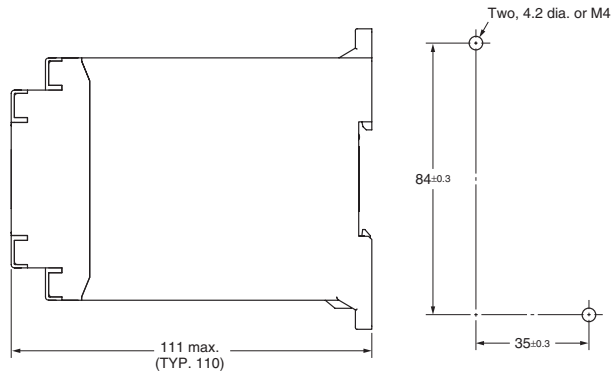

■ Accessories (Order Separately)

Current Transformer (CT)

E54-CT1

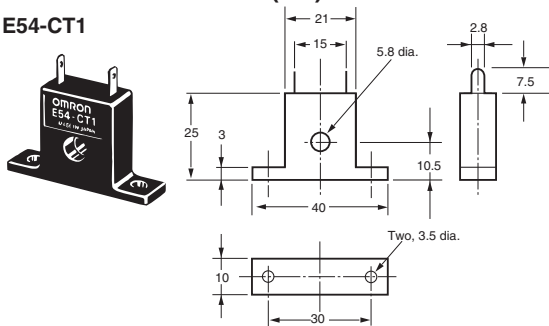

Current Transformer (CT)

E54-CT3

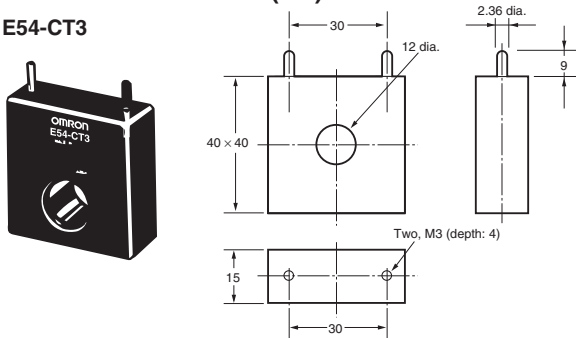

E54-CT3 Accessories

• Contactors

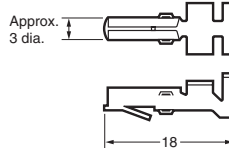

• Plugs

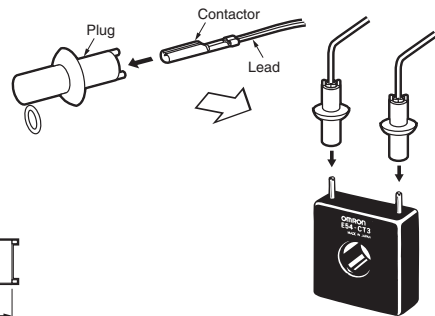
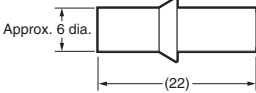

DIN Track

PPF-100N
PPF-50N

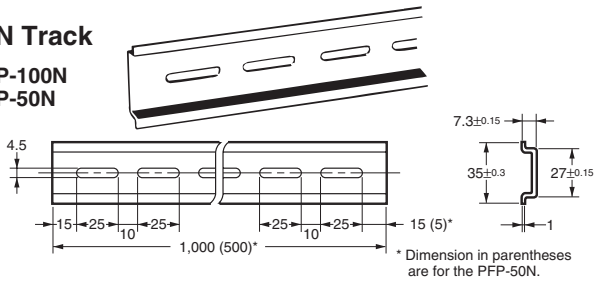

* Dimension in parentheses are for the PPF-50N.

End Plate (Stopper)

PPF-M

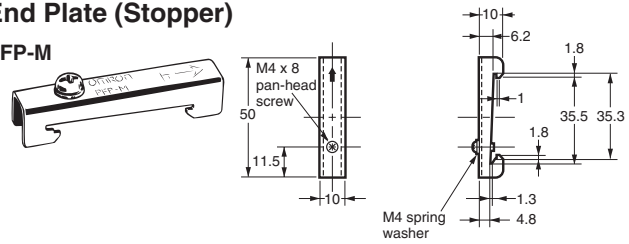

Precautions

⚠ WARNING

Do not touch the terminals and the wires while power is being supplied. Doing so may possibly result in electric shock. Make sure that the terminal cover is installed before using the product.



⚠ CAUTION

Do not allow pieces of metal, wire clippings, or fine metallic chips or filings from installation to enter the product. Doing so may occasionally result in electric shock, fire, or malfunction.



Do not use the product in locations of flammable or explosive gases. Doing so may occasionally result in minor or moderate explosion, causing minor or moderate injury, or property damage.



Do not attempt to disassemble, repair, or modify the product. Doing so may occasionally result in minor or moderate injury due to electric shock.



Perform correct setting of the product according to the application. Failure to do so may occasionally cause unexpected operation, resulting in minor or moderate injury, or damage to the equipment.



Ensure safety in the event of product failure by taking safety measures, such as installing a separate monitoring system to provide alarms for preventing excessive temperature rise. Product failure may occasionally prevent control operation, resulting in damage to the connected facilities and equipment.



Tighten the terminal screws securely using a tightening torque within the following ranges. Loose screws may occasionally cause fire, resulting in minor or moderate injury, or damage to the equipment.
Terminal screws: 0.40 to 0.56 N.m



■ Precautions for Safe Use

1. Do not use the product in the following locations.
 - Locations subject to direct radiant heat from heating equipment
 - Locations where the product may come into contact with water or oil
 - Locations subject to direct sunlight
 - Locations where dust or corrosive gases (in particular, sulfuric or ammonia gas) are present
 - Locations subject to extreme temperature changes
 - Locations where icing or condensation may occur
 - Locations subject to excessive shocks or vibration
2. Use this product within the rated load and power supply.
3. Ensure that the rated voltage is achieved no longer than 2 s after turning the power ON.
4. Use/store within the rated temperature and humidity ranges.
5. Minimum mounting distance of G3ZA is 10 mm. When mounting the G3ZA near the SSRs, mount the G3ZA so as to not interfere with the heat dissipation of the SSR.
6. Use the specified size of insulated-type crimp terminals (M3, width: 5.8 mm max.) for wiring and attach insulative sleeves. To connect bare wires, use AWG22 (cross section: 0.326 mm²) to AWG14 (cross section: 2.081 mm²) to wire the power supply terminals and AWG22 (cross section: 0.326 mm²) to AWG16 (cross section: 1.039 mm²) for other terminals.
7. Be sure to confirm the correct terminal and polarity when wiring the terminal block and connectors.
8. Do not connect any conductors to unused terminals.
9. In order to prevent inductive noise, wire the lines connected to the product separately from power lines carrying high voltages or currents. Do not wire in parallel with or in the same cable as power lines. Other measures for reducing noise include running lines along separate ducts and using shield lines.
10. Attach a surge suppressor or noise filter to peripheral devices that generate noise (in particular, motors, transformers, solenoids, magnetic coils, or other devices that have an inductance component). Do not install the product near devices generating strong high-frequency fields or surges. When using a noise filter, check the voltage and current and install it as close to the product as possible.
11. For a safety disconnection of the power-line in the application, the equipment must be provided with disconnecting devices suitable for isolation. (e.g., circuit breakers defined in IEC60947-2, power switches defined in IEC60947-3, power plugs, etc.)
12. The G3ZA is for **single-phase loads only**. Connect only single-phase zero-cross SSRs. Do not connect three-phase SSRs, magnetic relays, or SSRs that do not have a zero-cross function.

■ Precautions for Correct Use

Wiring

Use M3 crimp terminals.

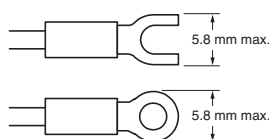

Use wires that withstand a minimum of 70 °C.

DIN Track

Secure the DIN Track with screws in at least three locations.

DIN Track: PFP-50N (50 cm)/PFP-100N (100 cm)

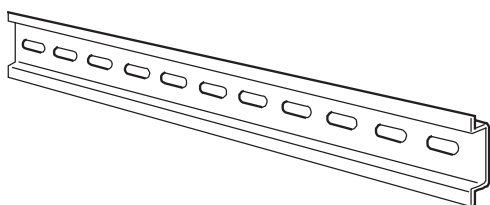

Mounting the G3ZA

Mount the G3ZA as shown in the diagram. First, pull down the DIN Track mounting hook (1) and hook the top of the G3ZA on the DIN Track (2). Then press the G3ZA onto the DIN Track far enough so that it can be locked in place (3) and push the DIN Track mounting hook up to lock the G3ZA in place (4).

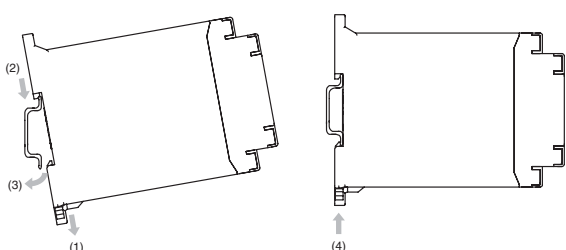

Removing the G3ZA

Use a flat-blade screwdriver to pull down the DIN Track mounting hook (1) and then pull out on the bottom of the G3ZA (2).

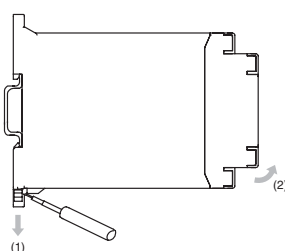

Mounting End Plates

Be sure to mount an End Plate on each side of the G3ZA so that it does not slide on the DIN Track.

To mount an End Plate, hook the bottom of the End Plate on the bottom of the DIN Track (1), place the top of the End Plate on the DIN Track (2), and then pull down on the End Plate. Tighten the screw on the End Plate to secure it.

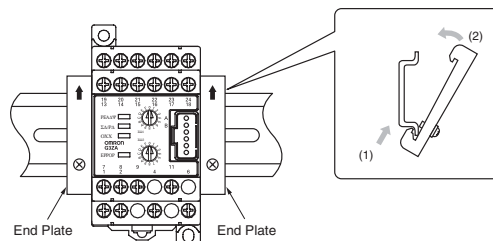

Note: Always mount one End Plate on each side of the G3ZA.

Installation Example

When installing the SSRs next to the G3ZA, provide sufficient space between the G3ZA and SSRs, as shown in the following diagram.

Reference example:

When applying 10 A to the G3PA-210B-VD (a manipulated variable of 100%), **separate the SSRs from the G3ZA by at least 20 mm.**

Do not touch the G3ZA while power is being supplied.

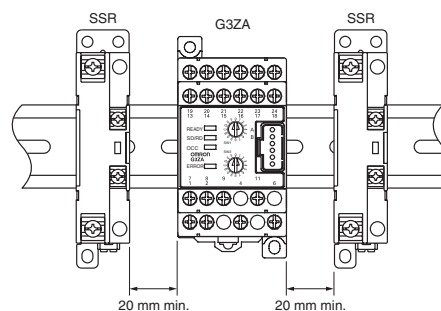

Mounting with Screws

Mounting Dimensions (Unit: mm)

