

Solid State Relays with Failure Detection Function G3PC

Detects failures in SSR used for heater temperature control and simultaneously outputs alarm signal. This SSR supports the safe design of heater control systems, and contributes to maintenance improvements by the user.



- Main detection items:
SSR short-circuits and SSR open-circuits
- Alarm output possible to NPN/PNP-input devices.
- The failure-detection function is built-in and power is supplied from the main circuit power supply making wiring simple.
- Slim design (width: 22.5 mm) incorporating a heat sink.
- In addition to screw mounting, DIN track mounting is also possible.
- Certified by EC, UL, and CSA.

Model Number Structure

Model Number Legend

G3PC-□□□-□
1 2 3 4 5

- 1. Basic Model Name**
G3PC: SSR with Failure Detection Function
- 2. Rated Load Power Supply Voltage**
2: 100 to 240 VAC
- 3. Rated Load Current**
20: 20 A (carry current)
- 4. Terminal Type**
B: Screw terminals
- 5. Certification**
VD: Certified by UL, CSA, and VDE

Ordering Information

List of Models

Insulation method	Zero cross function	Indicators	Rated output load	Model number
Phototriac coupler	Yes	Yes (See page 64)	20 A, 100 to 240 VAC (resistive load: AC, Class1)	G3PC-220B-VD

Note: When ordering, specify the rated input voltage.

Accessories (Order Separately)

Name	Dimensions	Model number
Mounting Track	50 cm (l) × 7.3 mm (t)	PFP-50N
	1 m (l) × 7.3 mm (t)	PFP-100N
	1 m (l) × 16 mm (t)	PFP-100N2

Specifications

■ Ratings (at an Ambient Temperature of 25°C)

Detection Power Supply

Rated power supply voltage	100 to 240 VAC (50/60 Hz)
Operating voltage range	75 to 264 VAC (50/60 Hz)
Current consumption	15 mA AC max. (at 200 VAC)

Operating Circuit

Input method	Voltage input
Rated input voltage	12 to 24 VDC
Operating input voltage range	9.6 to 30 VDC
Must operate voltage	9.6 VDC max.
Must release voltage	1 VDC min.
Input current	7 mA DC max. (at rated input voltage)

Main Circuit

Rated load voltage	100 to 240 VAC (50/60 Hz)
Operating voltage range	75 to 264 VDC (50/60 Hz)
Rated carry current	20 A (Ta = 40)
Minimum load current	0.1 A
Inrush current resistance (peak value)	220 A (60 Hz, 1 cycle)
Permissible (I ² t)	260 A ² s
Applicable load (with Class-1 AC resistive load)	4 kW (at 200 VAC)

Alarm Output

Output OFF collector voltage	30 VDC max.
Maximum carry current	0.1 A
Output form	Independent NPN open collector

■ Characteristics

Operate time	1/2 of load power source cycle + 1 ms max.	
Release time	1/2 of load power source cycle + 1 ms max.	
Main circuit	Output ON voltage drop	1.6 V rms max.
	OFF leakage current	10 mA max. (at 200 VAC)
Alarm output	Output ON voltage drop	1.5 V max.
	OFF leakage current	0.1 mA max.
Insulation resistance	100 MΩ min. (at 500 VDC)	
Dielectric strength	2,500 VAC, 50/60 Hz for 1 min	
Vibration resistance	Destruction: 10 to 55 to 10 Hz, 0.35-mm single amplitude	
Shock resistance	Destruction: 294 m/s ²	
Ambient temperature	Operating: -20 to 60°C (with no icing or condensation) Storage: -30 to 70°C (with no icing or condensation)	
Ambient humidity	45% to 85%	
Weight	Approx. 300 g	
Certified standards	UL508, CSA22.2 No. 14, EN60947-4-3 (IEC947-4-3); Certified by VDE	
EMC	Emission	EN55011 Group 1 Class B
	Immunity ESD	IEC947-4-3, EN61000-4-2
		4 kV contact discharge 8 kV air discharge
	Immunity Electromagnetic	IEC947-4-3, EN61000-4-3
		10 V/m (80 MHz to 1 GHz)
	Immunity EFT	IEC947-4-3, EN61000-4-4
		2 kV AC power-signal line
Immunity Surge transient	IEC947-4-3, EN61000-4-5	
	2 kV	
Immunity RF disturbance	IEC947-4-3, EN61000-4-6	
	10 V (0.15 to 80 MHz)	
Immunity Dips	IEC947-4-3, EN61000-4-11	

Engineering Data

Input Voltage vs. Input Current Input Voltage vs. Input Impedance

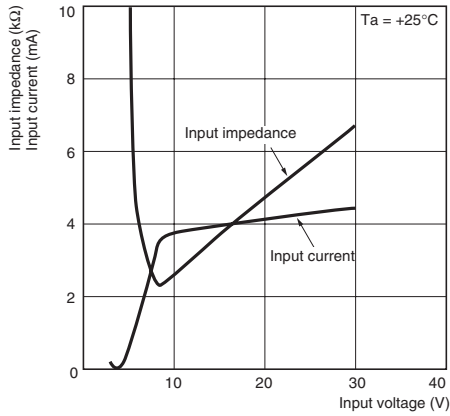

Load Current vs. Ambient Temperature

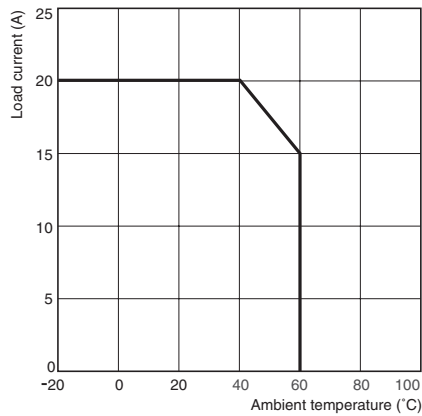

One Cycle Surge Current: Non-repetitive

The figure will be less than 1/2 the rated value for repetitive input.

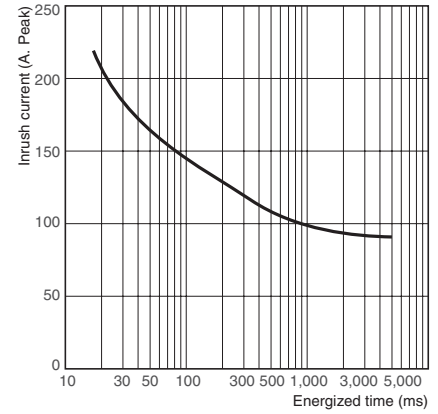

SSR

Operation

■ Failure Detection Function

Conditions for SSR Failure Detection

Failure mode (See note 1.)	Operating input (between terminals A1 and A2)	Detection time	Alarm display (See note 3.)	Alarm display (between terminals X1 and X2) (See note 3.)
SSR short-circuit	OFF	0.5 s max. (See note 2.)	Red	Open collector transistor output
SSR half-wave short-circuit	OFF			
SSR open-circuit	ON			
SSR half-wave open-circuit	ON			

- Note: 1.** The contents of each of the above failure modes is as follows:
 SSR short-circuit: SSR output circuit remains in the ON state.
 SSR half-wave short-circuit: SSR output circuit remains in the ON state in one direction.
 SSR open-circuit: SSR output circuit remains in the OFF state.
 SSR half-wave open-circuit: SSR output circuit remains in the OFF state in one direction.
 In addition to the failure modes listed above, detection of circuit disconnections for the load circuit is also possible. (As a rough guide, circuit disconnection will be detected if the load impedance is greater than or equal to 1 MΩ.)
- 2.** The same power supply is used for both the detection and for the output circuit and so detection is not performed during power interruptions.
- 3.** If power supply (terminal 3) is in the open state, the SSR will still turn ON and OFF in the same way but the failure detection function and alarm display will not operate properly.

Connection Diagrams (Main Circuit)

The following diagrams show the applicable load connection configurations for SSR failure detection.

Single Phase

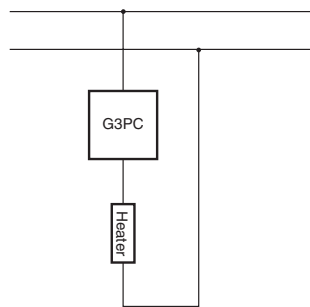

3-phase Star Connection

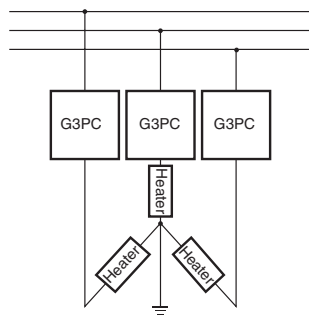

3-phase Delta Connection (3-phase, 2-wire Switching)

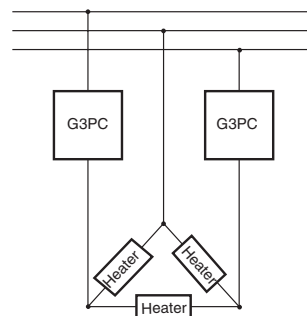

3-phase V Connection

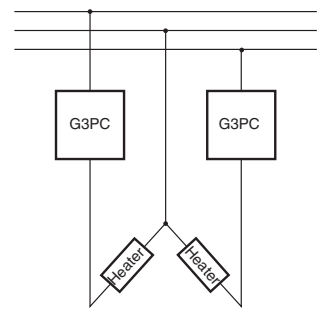

- Note: 1.** With 3-phase connection, so that the power supply voltage is applied between the G3PC's terminals 1/L1 and 3, connect the desired phase to terminal 3.
- 2.** Above mentioned products are 200V only. They are not suitable for three-phase 400V, but for three-phase 220V only.

Timing Chart

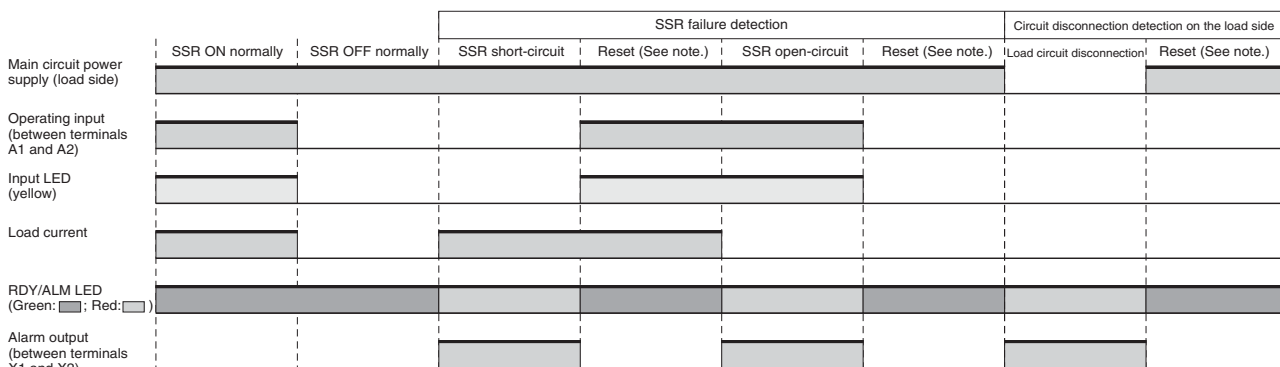

Note: After failure detection, if the detection conditions differ to the conditions given under *Conditions for SSR Failure Detection*, alarm output is reset.

Dimensions

G3PC-220B-VD

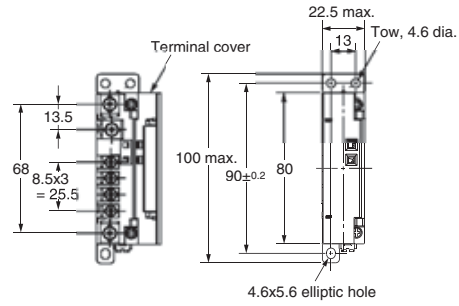
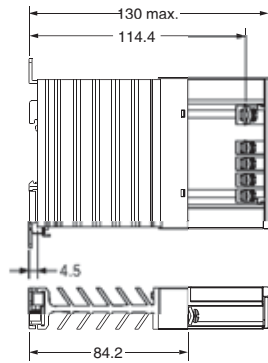
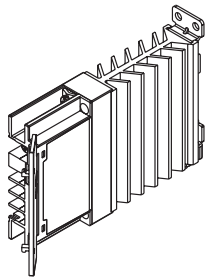

Mounting Holes

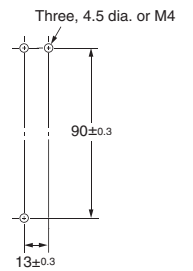

Note The above diagram is for when the terminal cover is open.

Note The above diagram is for when the terminal cover is closed.

Accessories (Order Separately)

Mounting Tracks PFP-100N, PFP-50N

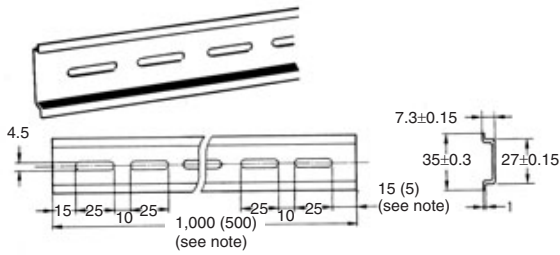

Note Values in parentheses indicate dimensions for the PFP-50N.

PFP-100N2

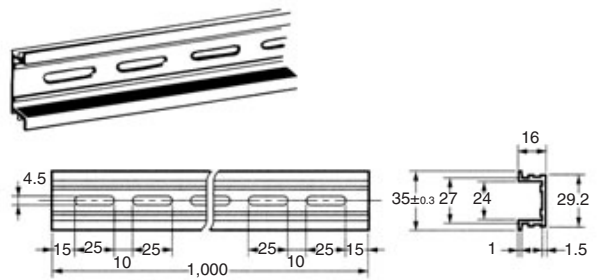

Installation

External Specifications

Terminal Arrangement

Terminal name	Terminal number	Screw size
Main circuit terminals (output)	1/L1, 2/T1	M4
Detection power supply terminal (input)	3	
Operating circuit terminals (input)	A1, A2	M3.5
Alarm output terminals (output)	X1, X2	

Indicators

Name	Symbol	Color	Meaning
Status indicators	RDY	Green	SSR normal
	ALM	Red	SSR failure detection and circuit disconnection detection
Input indicator	INPUT	Yellow	Operating

Note: The same indicator is used as both the power supply indicator and the alarm indicator.

Appearance

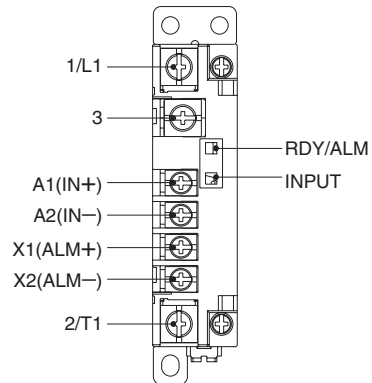

Connection Example

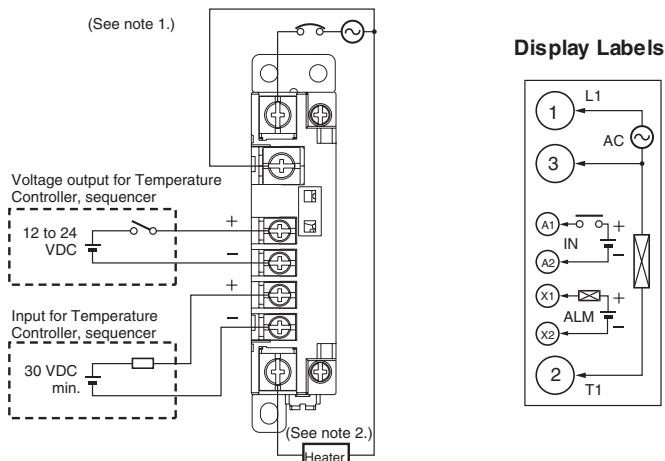

- Note:**
1. If the detection power supply terminal (terminal 3) is not connected, failure detection is not performed and so be sure to connect this terminal.
 2. If the load is connected to terminal 1/L1, failure detection may not operate correctly and so connect the load to terminal 2/T1.
 3. With inductive loads (relay coil, etc.), connect back-current prevention diodes to both sides of the load.

Safety Precautions

■ Precautions for Correct Use

Please observe the following precautions to prevent failure to operate, malfunction, or undesirable effect on product performance.

Mounting Method

DIN Track Mounting

When mounting to a DIN track, mount the G3PC until it clicks into place, otherwise it become loose during use and fall. Fix both ends with end plates.

Panel Mounting

When mounting directly to a panel, observe the following conditions:
Screw diameter: M4

Tightening torque: 0.98 to 1.47 N·m

Vertical Mounting

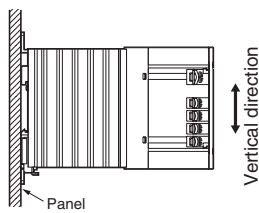

Horizontal Mounting

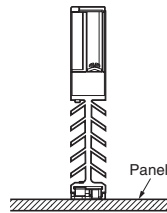

Note: Use the G3PC at a load current of 50% of the rated load current when it is mounted horizontally.

Close Mounting

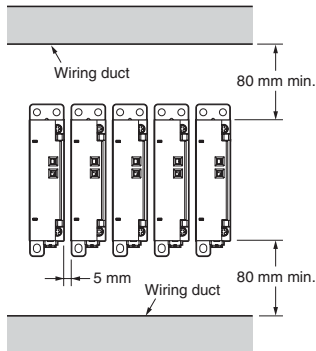

Note: Use the G3PC at a load current of 80% of the rated load current when it is mounted side by side.

Wiring

- When using crimp terminals, observe the terminal clearances shown below.

Main Circuit Power Supply (Terminals 1 to 3)

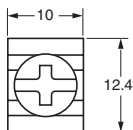

Operating Input/Alarm Output (Terminals A1, A2, X1, and X2)

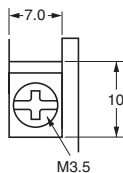

- Make sure that all lead wires are of a thickness appropriate for the current.
- The output terminals are charged, and touching them may result in electric shock, even when the G3PC is OFF. Separate the outputs from the power supply by installing a circuit-breaker at a higher level in the circuit.

Tightening Torque

Be sure to tighten the screws to the specified torques given below. Not doing so may result in malfunction.

Terminal number	Screw terminal diameter	Tightening torque
A1, A2, X1, X2	M3.5	0.59 to 1.18 N·m
1/L1, 2/T1, 3	M4	0.98 to 1.47 N·m