

Vision Sensor F210



F210

Features

Flow Menus

Flow Menus select the required processing items from the library, combining and linking them for you

Ideal for the following

- Stabilize measurement images by filtering the required number of times.
- Perform measurements according to workpiece tolerance by changing the measurement area based on measurement results
- Periodically check for data variations by outputting the maximum and minimum values for each 10 measurements,

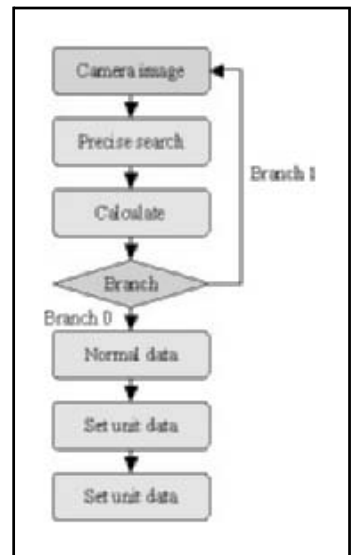

Features

Macros

Augment Flow Menus using a PC text editor. The Software package can be edited using text commands to customize I/O controls, displays, and GUI

Programs can be created using only a text editor, with no need for any special development environment.

Ideal for the following

- Creating special menus.
- Displaying and outputting the date and time of NG measurements.
- Automatically saving NG images to a Memory Card.
- Changing the number of registered product types.

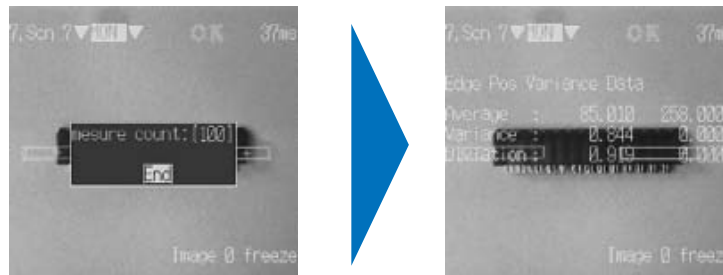

Special menus using macros

Customization Manual

The know-how from the past is incorporated in a manual so that Reverse Customization can be used to determine the best method to execute the desired process.

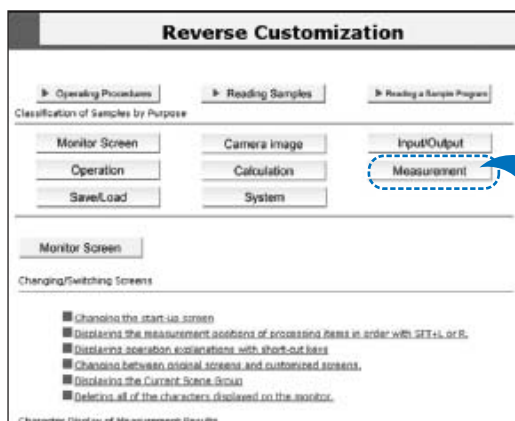

- Building Flow Menus and Using Macros
When an item is selected for operation, a sample program and explanation are displayed. Multiple samples can be easily combined.



Ordering information

Name		Model	Remarks
Controller		F210-C10	NPN Input/Output
		F210-C15	PNP Input/Output
Double-speed camera	Camera with intelligent lighting	F160-SLC20	
		F160-SLC50	
	Camera only	F160-S1	
		F160-S2	With partial scan function.
Compatible F150 cameras	Camera with intelligent lighting	F150-SLC20	
		F150-SLC50	
	Camera with light	F150-SL20A	
		F150-SL50A	
Camera only		F150-S1A	
Console		F160-KP	
		F150-KP	
Color LCD monitor		F150-M05L	
Monochrome CRT Video monitor		F150-M09	
Memory card		F160-N64S(S)	Memory capacity 64 MB
Camera cable		F150-VS	For Double-speed Camera and compatible F150 Cameras. Cable length: 3 m ^{*1}
Monitor cable		F150-VM	Cable length: 2 m ^{*1}
Parallel cable		F160-VP	Loose-wire cable for parallel I/O connectors. Cable length: 2 m

*1. Other length on request.

Processing Item Support

The F250-UM3FE (UM3ME) Application Software supports approximately 70 different processing items. These can be freely combined for inspections as needed. Image input, measurement support, branch control, results output, and results display can be used in common for all of the models (F210 and F250).





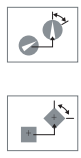

Image Input Functions

- Inputting Camera Images
- Switching Cameras
- Changing Filtering
- Filtering Again







Position Compensation Functions

Compensation	Processing item	Controller		Remarks
		F210	F250	
	Binary Position Compensation	YES	YES	---
	Circle Position Compensation	NO	YES	---
	EC Position Compensation	YES	YES	---
	Edge Position Compensation	YES	YES	---
	Model Position Compensation	NO	YES	Enables high-speed processing compared to the model position compensation #.
Model Position Compensation #	YES	YES	---	

General Measurement Functions

Application (measurement)	Processing item	Controller		Remarks	
		F210	F250		
	Binary Defect	YES	YES	Up to eight regions can be set per Unit, with results displayed in a list.	
	Binary Gravity and Area	YES	YES	Only one region can be set per Unit. Menu levels are simple and easy to understand.	
	Binary Area (Variable Box)	YES	YES	Used for inspecting measurement items with varying positions and sizes.	
Position     	Center-of-gravity detection (Processing time: Low)	Binary Defect	YES	YES	Up to eight regions can be set per Unit, with results displayed in a list.
		Binary Gravity and Area	YES	YES	Only one region can be set per Unit. Menu levels are simple and easy to understand.
		Binary Area (Variable Box)	YES	YES	Used for inspecting measurement items with varying positions and sizes.
	Coordinate detection (Processing time: High)	Gray Search	YES	YES	Uses gray models to detect positions in pixel units.
		Precise Search	YES	YES	Uses gray models to detect positions in sub-pixel units.
		Flexible Search	YES	YES	Multiple models are registered to enable searching even when there is variation.
		Pattern	NO	YES	Up to 64 regions can be registered per Unit, and high-speed processing is possible. (See note.)
		ECM Search	YES	YES	Uses edge code models so that processing is not affected by deformation or dirt.
	Coordinate detection (Rotation in measurement item)	EC Positioning	YES	YES	No model registration is required. Searches using shape information such as "round" or "angular."
		Rotation Positioning	NO	YES	High-speed processing is possible. (See note.)
Dimensions measurement	Rotation Search	YES	YES	---	
	Gray Edge Position_8	YES	YES	Up to eight regions can be set per Unit, with results displayed in a list.	
	Gray Edge Position_1	YES	YES	Only one region can be set per Unit. Menu levels are simple and easy to understand.	
Position deviation detection	Gray Edge Width	YES	YES	---	
	Relative Position	YES	YES	---	

Note: These processing items are most effective when set immediately after image input processing item (Camera image input or Camera switching). Depending on conditions, however, high-speed processing may not be possible.

Application (measurement)	Processing item	Controller		Remarks
		F210	F250	
Defect 	Surface Defect	YES	YES	Only one region can be set per Unit. Menu levels are simple and easy to understand.
	Density Defect	NO	YES	Up to eight regions can be set per Unit, with results displayed in a list. The number of Units can be reduced.
	Surface Defect (Variable Box)	YES	YES	Used for inspecting measurement items with varying positions and sizes.
	EC Defect	YES	YES	Uses edge codes for defect inspection so that processing is not affected by deformation or dirt.
	Fine Matching	YES	YES	Accurately detects differences with models.
Characters 	QUEST Character Verification	YES	YES	Used to verify multiple characters.
	Lot Number OCR 1	YES	YES	Handles lot numbers that are changed daily, weekly, monthly, or annually.
	OCR for 1 Character	YES	YES	---
Angle 	Binary Defect	YES	YES	Up to eight regions can be set per Unit, with results displayed in a list. The number of Units can be reduced.
	Binary Gravity and Angle	YES	YES	Only one region can be set per Unit. Menu levels are simple and easy to understand.
	Rotation Positioning	NO	YES	High-speed processing is possible. (See note.)
	Rotation Search	YES	YES	Used when the measurement item rotates.
	Circular Angle	YES	YES	Used only for circular measurement items. Enables higher-speed processing compared to Rotation Search. (See note.)
Quantities 	Labeling	YES	YES	Counts up to 2,500.
	Label Data	YES	YES	Gets label measurement values from other Units.
	Edge Pitch	YES	YES	Gets the number, pitch, and width.
	EC Circle Count	YES	YES	Finds circles using "round" shape information so that processing is not affected even if the circles are deformed or dirty.
Shapes (correlation values) 	Pattern	NO	YES	Up to 64 regions can be registered per Unit, enabling high-speed processing. (See note.)
	Flexible Search	YES	YES	Searching can be performed even if there is variation in model images.
	Fine Matching	YES	YES	Accurately detects differences with models.
Classification 	Classification	NO	YES	Enables higher-speed processing compared to Classification #. (See note.)
	Classification #	YES	YES	---
Brightness 	Density Data	YES	YES	---

Note: These processing items are most effective when set immediately after image input processing item (Camera image input or Camera switching). Depending on conditions, however, high-speed processing may not be possible.

Measurement Support Functions

- Calculation
- Get unit data
- Set unit data
- Wait
- Elapsed time
- Trend monitor

Results Output Functions

- Memory card data output
- DO data output
- Host link data output
- Normal data output
- DO judgement output

Branch Control Functions

- Conditional branch
- DI branch
- End

Results Display Functions

- String display
- Measurement display
- Judgement display
- Item display
- Time display
- Figure display
- Line results display
- Box display
- Circle display
- Cursor display
- Newest NG image display

F210

System Configuration

Camera with Lighting

Cameras with Intelligent Lighting
F160-SLC20
F160-SLC50



Cameras with Intelligent Lighting
F150-SLC20
F150-SLC50



Cameras with Light Source
F150-SL20A
F150-SL50A



Camera

F150-S1A



F160-S1/S2
(Double-speed Camera)



Lense
(See note 2.)

3Z4S-LE C1614A



3Z4S-LE B2514D



3Z4S-LE B5014A



Lighting (See note 2.)

F150-LT20A
F150-LT50A



Software Package

F250-UM3FE (Flow Menu Format)
F250-UM3ME (Flow Menu and Macro Format)



Console

F160-KP F150-KP



Monitor

Color LCD Monitor
F150-M05L



Monochrome CRT Video
Monitor
F150-M09



Memory Card

F160-N64S (S) (64 MB)



F210-C10/C15

F250-C50/C55

RS-232C/422
(Common use)
Ethernet (F250)

Personal computer



Parallel Cable

Synchronous Sensor
Programmable Controller



Note 1: Separate robot cable specifications (F150-VSB) are available.
Note 2: In addition, lenses and lighting are available.

Rating/Performance

Controller

Item	Specifications	F210-C10/C15	F250-C50/C55
Connectable Cameras		F150-S1A/-SL20A/-SL50A/-SLC20/-SLC50, F160-S1/-S2/-SLC20/-SLC50, F300-S2R/-S3DR, etc.	
Number of Cameras connectable		2	4
Number of pixels		512 × 484 (H × V)	
Number of scenes		32 (Expansion possible using Memory Cards.)	
Image storage function		Maximum of 35 images stored	
Filtering		Smoothing (strong, weak), edge enhancement, edge extraction (horizontal, vertical, both), dilation, erosion, median, background suppression	
Operation and settings		Installing measurement items using application software, and combining and setting measurement items by menu operations	
Menu language		Japanese or English (Can be switched.)	
Trend monitor function		Supported	
Memory card slots		1	2
Monitor interface		1 channel	Composite video output: 1 channel, S-VIDEO output: 1 channel
Ethernet		Not supported.	10Base-T: 1 channel
Serial communications		RS-232C/422A: 1 channel	
Parallel I/O		13 inputs and 22 outputs	21 inputs and 46 outputs
Strobe interface		2 channels (included in parallel outputs)	4 channels (included in parallel outputs)
Power supply voltage		20.4 to 26.4 VDC	
Current consumption		Approx. 1.6 A (when two F160-SLC50 Cameras are connected)	Approx. 3.7 A (when four F160-SLC50 Cameras are connected)
Ambient temperature		Operating: 0 to 50°C Storage: -25 to 65°C (with no icing or condensation)	
Ambient humidity		Operating and storage: 35% to 85% (with no condensation)	
External dimensions		56 × 160 × 110 (W × H × D) mm (not including connectors and other protruding parts)	270 × 81 × 197 (W × H × D) mm
Weight		Approx. 570 g (Controller only)	Approx. 2.7 kg (Controller only)

Dimensions

Controller
F210-C10/C15

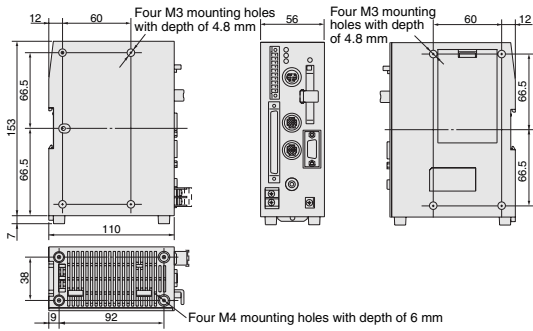

F250-C50/C55

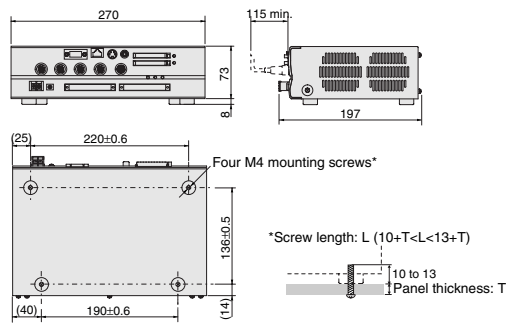

Camera
F160-S1/S2

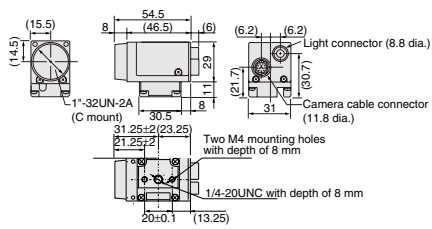

Console
F160-KP

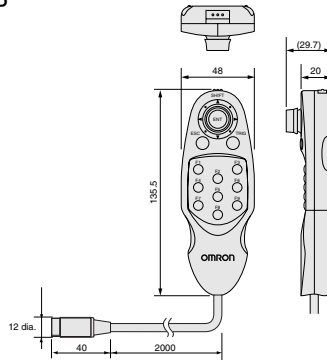

Liquid Crystal Monitor
F150-M05L

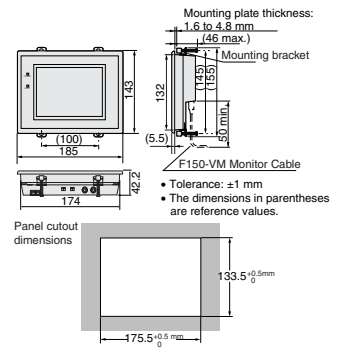

ALL DIMENSIONS SHOWN ARE IN MILLIMETERS.
To convert millimeters into inches, multiply by 0.03937. To convert grams into ounces, multiply by 0.03527.