

General-purpose Basic Switch

Z

Best-selling Basic Switch Boasting High Precision and Wide Variety

- A large switching capacity of 15 A with high repeat accuracy.
- A wide range of variations in contact form for your selection: basic, split-contact, maintained-contact, and adjustable contact gap types.
- A series of standard models for micro loads is available.
- A series of molded terminal-type models incorporating safety terminal protective cover is available.



Model Number Structure

■ Configuration

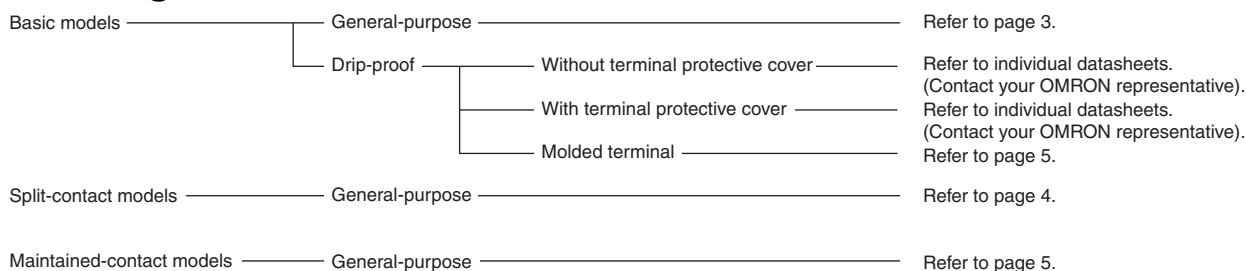

Basic Models

General-purpose

A variety of actuators is available for a wide range of application.

The contact mechanism of models for micro loads is a crossbar type with gold-alloy contacts, which ensures highly reliable operations for micro loads.

Contact Gap:

H: 0.25 mm (high-sensitivity, micro voltage current load)

G: 0.5 mm (standard)

E: 1.8 mm (high-capacity)

F: 1.0 mm (split-contact models)

Split-contact Models

This type is identical in construction to the general-purpose basic switch except that it has two pairs of simultaneous acting contacts by splitting moving contacts.

Since the moving contacts are connected to a common terminal, either parallel or series connection is possible.

Highly reliable micro load switching is ensured if the model is used as a twin-contact switch.

Maintained-contact Models

The maintained-contact type has a reset button at the bottom of the switch case, in addition to the pushbutton (plunger) located on the opposite side of the reset button. Use these buttons alternately.

Since the Switch has greater pretravel than overtravel, it is suitable for use in reversible control circuits, manual reset circuits, safety limit circuits, and other circuits which are not preferable for automatic resetting. (For further details, refer to individual datasheets.)

■ Model Number Legend

Basic Models

Z-□□□□-□
1 2 3 4 5

1. Ratings

- 01: 0.1 A (for micro load)
- 15: 15 A

2. Contact Gap

- H: 0.25 mm (high-sensitivity, micro load)
- G: 0.5 mm (standard)
- E: 1.8 mm (high-capacity)

3. Actuator

- None: Pin plunger
- S: Slim spring plunger
- D: Short spring plunger
- K: Spring plunger (medium OP)
- K3: Spring plunger (high OP)
- Q3: Panel mount plunger (low OP)
- Q: Panel mount plunger (medium OP)
- Q8: Panel mount plunger (high OP)
- Q22: Panel mount roller plunger
- Q21: Panel mount cross roller plunger
- L: Leaf spring (high OF)
- L2: Roller leaf spring
- W21: Short hinge lever
- W: Hinge lever (low OF)
- W3: Hinge lever (medium OF)
- W32: Hinge lever (high OF)
- W4: Low-force hinge lever
- W44: Long hinge lever
- W78: Low-force wire hinge lever (low OF)
- W52: Low-force wire hinge lever (high OF)
- W22: Short hinge roller lever
- W2: Hinge roller lever
- W25: Hinge roller lever (large roller)
- W49: Short hinge cross roller lever
- W54: Hinge cross roller lever
- W2277: Unidirectional short hinge roller lever (Low OF)
- M: Reverse hinge lever
- M22: Reverse short hinge roller lever
- M2: Reverse hinge roller lever
- NJ: Flexible rod (high OF)
- NJS: Flexible rod (low OF)

4. Degree of Protection

- None: General-purpose
- 55: Drip-proof
- A55: Drip-proof (including the terminals)

5. Terminals

- None: Solder terminal
- B: Screw terminal (with toothed washer)
- B5V: Screw terminal with terminal cover (for Z-15G□A55 only)

Note: For combinations of models, refer to the following pages.

Split-contact Models

Z-10F□Y-B
1 2 3 4 5

1. Ratings

- 10: 10 A

2. Contact Gap

- F: 1 mm (high-capacity)

3. Actuator

- None: Pin plunger
- S: Slim spring plunger
- D: Short spring plunger
- Q: Panel mount plunger
- Q22: Panel mount roller plunger
- W: Hinge lever
- W22: Short hinge roller lever
- W2: Hinge roller lever
- M22: Reverse short hinge roller lever

4. Construction

- Y: Split-contact models

5. Terminals

- None: Solder terminal
- B: Screw terminal (with toothed washer)

Maintained-contact Models

Z-15-E□R
1 2 3 4

1. Ratings

- 15: 15 A

2. Contact Gap

- E: 1.8 mm (High capacity)

3. Actuator

- None: Pin plunger
- S: Slim spring plunger
- W: Hinge lever















4. Structure





- R: Maintained-contact models

Ordering Information

■ List of Models

Basic Models (General-purpose)

Actuator			Standard	High-sensitivity	High-capacity	Micro load
			G (0.5 mm)	H (0.25 mm)	E (1.8 mm)	H (0.25 mm)
Pin plunger 		Solder terminal	Z-15G	Z-15H	Z-15E	Z-01H
		Screw terminal	Z-15G-B	Z-15H-B	Z-15E-B	Z-01H-B
Slim spring plunger 		Solder terminal	Z-15GS	Z-15HS	---	Z-01HS
		Screw terminal	Z-15GS-B	Z-15HS-B	---	Z-01HS-B
Short spring plunger 		Solder terminal	Z-15GD	Z-15HD	Z-15ED	Z-01HD
		Screw terminal	Z-15GD-B	Z-15HD-B	Z-15ED-B	Z-01HD-B
Panel mount plunger 	Low OP	Solder terminal	Z-15GQ3	---	---	---
		Screw terminal	Z-15GQ3-B	---	---	---
	Medium OP	Solder terminal	Z-15GQ	Z-15HQ	Z-15EQ	Z-01HQ
		Screw terminal	Z-15GQ-B	Z-15HQ-B	Z-15EQ-B	Z-01HQ-B
	High OP	Solder terminal	Z-15GQ8	---	---	---
		Screw terminal	Z-15GQ8-B	---	---	---
Panel mount roller plunger 		Solder terminal	Z-15GQ22	Z-15HQ22	Z-15EQ22	---
		Screw terminal	Z-15GQ22-B	Z-15HQ22-B	Z-15EQ22-B	---
Panel mount cross roller plunger 		Solder terminal	Z-15GQ21	Z-15HQ21	Z-15EQ21	---
		Screw terminal	Z-15GQ21-B	Z-15HQ21-B	Z-15EQ21-B	---
Leaf spring 		Solder terminal	Z-15GL	---	---	---
		Screw terminal	Z-15GL-B	---	---	---
Roller leaf spring 		Solder terminal	Z-15GL2	---	---	---
		Screw terminal	Z-15GL2-B	---	---	---
Short hinge lever 		Solder terminal	Z-15GW21	---	---	---
		Screw terminal	Z-15GW21-B	---	---	---
Hinge lever 	Low OF	Solder terminal	Z-15GW	Z-15HW	---	---
		Screw terminal	Z-15GW-B	Z-15HW-B	---	---
	Medium OF	Solder terminal	Z-15GW3	---	---	---
		Screw terminal	Z-15GW3-B	---	---	---
	High OF	Solder terminal	Z-15GW32	---	---	---
		Screw terminal	Z-15GW32-B	---	---	---
Low-force hinge lever 		Solder terminal	Z-15GW4	Z-15HW24	---	---
		Screw terminal	Z-15GW4-B	Z-15HW24-B	---	---
Low-force wire hinge lever 	Low OF	Solder terminal	---	Z-15HW78	---	---
		Screw terminal	---	Z-15HW78-B	---	---
	High OF	Solder terminal	---	Z-15HW52	---	---
		Screw terminal	---	Z-15HW52-B	---	---
Short hinge roller lever 		Solder terminal	Z-15GW22	Z-15HW22	Z-15EW22	Z-01HW22
		Screw terminal	Z-15GW22-B	Z-15HW22-B	Z-15EW22-B	Z-01HW22-B
Short hinge cross roller lever 		Solder terminal	Z-15GW49	---	---	---
		Screw terminal	Z-15GW49-B	---	---	---
Hinge roller lever 	Parallel	Solder terminal	Z-15GW2	Z-15HW2	---	---
		Screw terminal	Z-15GW2-B	Z-15HW2-B	---	---
	Large roller	Solder terminal	Z-15GW25	---	---	---
		Screw terminal	Z-15GW25-B	---	---	---

Actuator	Standard		High-sensitivity	High-capacity	Micro load
	G (0.5 mm)		H (0.25 mm)	E (1.8 mm)	H (0.25 mm)
Hinge cross roller lever 	Solder terminal	Z-15GW54	---	---	---
	Screw terminal	Z-15GW54-B	---	---	---
Unidirectional short hinge roller lever 	Solder terminal	Z-15GW2277	---	---	---
	Screw terminal	Z-15GW2277-B	---	---	---
Reverse hinge lever (see note) 	Solder terminal	Z-15GM	---	---	---
	Screw terminal	Z-15GM-B	---	---	---
Reverse short hinge roller lever (see note) 	Solder terminal	Z-15GM22	---	---	---
	Screw terminal	Z-15GM22-B	---	---	---
Reverse hinge roller lever (see note) 	Solder terminal	Z-15GM2	---	---	---
	Screw terminal	Z-15GM2-B	---	---	---





Note: The pin plungers of reverse-type models are continuously pressed by the actuator levers with compression coil springs and the pin plungers are freed by operating the levers. Reverse-type models are highly vibration- and shock-resistant because the pin plungers are normally pressed.





Minimum Order Lot

The following models are available at the minimum order lot specified below. Orders must be placed per lot.

Actuator	Standard	High-sensitivity	Minimum order lot (pcs)
	G (0.5 mm)	H (0.25 mm)	
Short spring plunger	Z-15GD-B	---	10
Panel mount plunger	Z-15GQ	---	
	Z-15GQ-B	---	
	Z-15GQ8-B	---	
Panel mount roller plunger	Z-15GQ22	---	
	Z-15GQ22-B	---	
Panel mount cross roller plunger	Z-15GQ21-B	---	
Short hinge lever	Z-15GW21-B	---	
Hinge lever	Z-15GW	---	
	Z-15GW-B	---	
Low-force hinge lever	Z-15GW4-B	Z-15HW24-B	
Low-force hinge wire lever	---	Z-15HW78-B	
Short hinge roller lever	Z-15GW22	---	
	Z-15GW22-B	---	
Hinge roller lever	Z-15GW2	---	
	Z-15GW2-B	---	
Reverse short hinge roller lever	Z-15GM22-B	---	
Reverse hinge roller lever	Z-15GM2-B	---	



Split-contact Models

Actuator		F (1.0 mm)	
Pin plunger 	Solder terminal	---	
	Screw terminal	Z-10FY-B	
Slim spring plunger 	Solder terminal	---	
	Screw terminal	Z-10FSY-B	
Short spring plunger 	Solder terminal	---	
	Screw terminal	Z-10FDY-B	
Panel mount plunger 	Medium OP	Solder terminal	---
		Screw terminal	Z-10FQY-B











Actuator		F (1.0 mm)	
Panel mount roller plunger 		Solder terminal	---
		Screw terminal	Z-10FQ22Y-B
Hinge lever 	Low OP	Solder terminal	---
		Screw terminal	Z-10FWY-B
Short hinge roller lever 		Solder terminal	---
		Screw terminal	Z-10FW22Y-B
Hinge roller lever 	Parallel	Solder terminal	---
		Screw terminal	Z-10FW2Y-B
Reverse short hinge roller lever 		Solder terminal	---
		Screw terminal	Z-10FM22Y-B





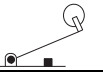

Note: The pin plungers of reverse-type models are continuously pressed by the actuator levers with compression coil springs and the pin plungers are freed by operating the levers. Reverse-type models are highly vibration- and shock-resistant because the pin plungers are normally pressed.

Maintained-contact Models

Actuator	Maintained-contact model
Pin plunger 	Z-15ER
Slim spring plunger 	Z-15ESR
Hinge lever 	Z-15EWR

Basic Models (Drip-proof Models)

Actuator		Basic model (drip-proof)			
		Standard		Micro load	
		G (0.5 mm)		H (0.25 mm)	
		Without drip-proof terminal protective cover	With drip-proof terminal protective cover	Without drip-proof terminal protective cover	
Pin plunger 		Solder terminal	Z-15G55	---	Z-01H55
		Screw terminal	Z-15G55-B	Z-15GA55-B5V	Z-01H55-B
Short spring plunger 		Solder terminal	Z-15GD55	---	Z-01HD55
		Screw terminal	Z-15GD55-B		Z-01HD55-B
Spring plunger 	Medium OP	Solder terminal	Z-15GK55	---	---
		Screw terminal	Z-15GK55-B		
	High OP	Solder terminal	Z-15GK355	---	---
		Screw terminal	Z-15GK355-B	Z-15GK3A55-B5V	
Panel mount plunger 	Medium OP	Solder terminal	Z-15GQ55	---	---
		Screw terminal	Z-15GQ55-B	Z-15GQA55-B5V	
Panel mount roller plunger 		Solder terminal	Z-15GQ2255	---	---
		Screw terminal	Z-15GQ2255-B	Z-15GQ22A55-B5V	
Panel mount cross roller plunger 		Solder terminal	---	---	---
		Screw terminal	Z-15GQ2155-B	Z-15GQ21A55-B5V	
Leaf spring 		Solder terminal	Z-15GL55	---	---
		Screw terminal	Z-15GL55-B		
Roller leaf spring 		Solder terminal	Z-15GL255	---	---
		Screw terminal	Z-15GL255-B		
Short hinge lever 		Solder terminal	Z-15GW2155	---	---
		Screw terminal	Z-15GW2155-B		
Long hinge lever 		Solder terminal	Z-15GW4455	---	---
		Screw terminal	Z-15GW4455-B	Z-15GW44A55-B5V	
Hinge lever 		Solder terminal	Z-15GW55	---	---
		Screw terminal	Z-15GW55-B	Z-15GWA55-B5V	
Short hinge roller lever 		Solder terminal	Z-15GW2255	---	Z-01HW2255
		Screw terminal	Z-15GW2255-B	Z-15GW22A55-B5V	Z-01HW2255-B

Actuator			Basic model (drip-proof)		
			Standard		Micro load
			G (0.5 mm)		H (0.25 mm)
			Without drip-proof terminal protective cover	With drip-proof terminal protective cover	Without drip-proof terminal protective cover
 Hinge roller lever	Parallel	Solder terminal	Z-15GW255	---	---
		Screw terminal	Z-15GW255-B	Z-15GW2A55-B5V	
 Unidirectional short hinge roller lever		Solder terminal	Z-15GW227755	---	---
		Screw terminal	Z-15GW227755-B	Z-15GW2277A55-B5V	
 Reverse hinge lever (see note 1)		Solder terminal	Z-15GM55	---	---
		Screw terminal	Z-15GM55-B		
 Reverse short hinge roller lever (see note 1)		Solder terminal	Z-15GM2255	---	---
		Screw terminal	Z-15GM2255-B		
 Reverse hinge roller lever (see note 1)		Solder terminal	Z-15GM255	---	---
		Screw terminal	Z-15GM255-B		
 Flexible rod (coil spring) (see note 2)		Solder terminal	Z-15GNJ55	---	---
		Screw terminal	Z-15GNJ55-B		

Note: 1. The pin plungers of reverse-type models are continuously pressed by the actuator levers with compression coil springs and the pin plungers are freed by operating the levers.
 2. The tip is made of resin.

Minimum Order Lot

The following models are available at the minimum order lot specified below. Orders must be placed per lot.

Actuator	Standard		High-sensitivity	Minimum order lot
	G (0.5 mm)		H (0.25 mm)	
Short spring plunger	Z-15GD55-B	---	---	10
Spring plunger	Z-15GK55-B	---	---	
Hinge lever	Z-15GW4455-B	---	---	
	Z-15GW55	---	---	
	Z-15GW55-B	---	---	
Short hinge roller lever	Z-15GW2255	---	---	
	Z-15GW2255-B	---	---	
Hinge roller lever	Z-15GW255-B	---	---	
Flexible rod (coil spring)	Z-15GNJ55-B	---	---	
Flexible rod (steel wire)	---	---	Z-15HNJS55-B	

Basic Models (Drip-proof High-sensitivity Models)

Actuator		High-sensitivity	
		H (0.25 mm)	
 Flexible rod (steel wire)	Solder terminal	Z-15HNJS55	
	Screw terminal	Z-15HNJS55-B	

Specifications

Approved Standards

Agency	Standard	File No.
UL	UL508	E41515
CSA	CSA C22.2 No. 55	LR21642
TÜV Rheinland	EN61058-1	R9451585

Approved Standard Ratings

UL508 (File No. E41515)

CSA C22.2 No.55 (File No. LR21642)

Rated voltage	Z-15	Z-10F	Z-01H
125 VAC	15 A 1/8 HP	6 A 1/10 HP	0.1 A
250 VAC	15 A 1/4 HP	6 A 1/8 HP	---
480 VAC	15 A	6 A	---
30 VDC	---	---	0.1 A
125 VDC	0.5 A	0.6 A	---
250 VDC	0.25 A	0.3 A	---

EN (EN61058-1)

Rated voltage	Z-15H□-B	Z-15G□-B	Z-01H□-B
250 VAC	15 A	15 A	---
125 VAC	---	---	0.1 A
30 VDC	---	---	0.1 A

Note: Consult with OMRON about approved part numbers by standards.

Ratings

Z-15 (Except Micro Load and Flexible Rod Models)

Item Model	Rated voltage	Non-inductive load				Inductive load			
		Resistive load		Lamp load		Inductive load		Motor load	
		NC	NO	NC	NO	NC	NO	NC	NO
G, H, E	125 VAC 250 VAC 500 VAC	15 (10) A (see note) 15 (10) A (see note) 10 A		3 A 2.5 A 1.5 A	1.5 A 1.25 A 0.75 A	15 (10) A (see note) 15 (10) A (see note) 6 A		5 A 3 A 1.5 A	2.5 A 1.5 A 0.75 A
G	8 VDC 14 VDC 30 VDC 125 VDC 250 VDC	15 A 15 A 6 A 0.5 A 0.25 A		3 A 3 A 3 A 0.5 A 0.25 A	1.5 A 1.5 A 1.5 A 0.5 A 0.25 A	15 A 10 A 5 A 0.05 A 0.03 A		5 A 5 A 5 A 0.05 A 0.03 A	2.5 A 2.5 A 2.5 A 0.05 A 0.03 A
H	8 VDC 14 VDC 30 VDC 125 VDC 250 VDC	15 A 15 A 2 A 0.4 A 0.2 A		3 A 3 A 2 A 0.4 A 0.2 A	1.5 A 1.5 A 1.4 A 0.4 A 0.2 A	15 A 10 A 1 A 0.03 A 0.02 A		5 A 5 A 1 A 0.03 A 0.02 A	2.5 A 2.5 A 1 A 0.03 A 0.02 A
E	8 VDC 14 VDC 30 VDC 125 VDC 250 VDC	15 A 15 A 15 A 0.75 A 0.3 A		3 A 3 A 3 A 0.75 A 0.3 A	1.5 A 1.5 A 1.5 A 0.75 A 0.3 A	15 A 15 A 10 A 0.4 A 0.2 A		5 A 5 A 5 A 0.4 A 0.2 A	2.5 A 2.5 A 2.5 A 0.4 A 0.2 A

Note: Figures in parentheses are for the Z-15HW52 and Z-15HW78(-B) models, the AC ratings of these models are 125 and 250 V only.

Z-15 (Flexible Rod Models)

Rated voltage	Non-inductive load				Inductive load			
	Resistive load		Lamp load		Inductive load		Motor load	
	NC	NO	NC	NO	NC	NO	NC	NO
125 VAC 250 VAC	15 A		2 A 1 A	1 A 0.5 A	7 A 5 A		2.5 A 1.5 A	2 A 1 A
8 VDC 14 VDC 30 VDC 125 VDC 250 VDC	15 A 15 A 2 A 0.4 A 0.2 A		2 A 2 A 2 A 0.4 A 0.2 A	1 A 1 A 1 A 0.4 A 0.2 A	7 A 7 A 1 A 0.03 A 0.02 A		3 A 3 A 1 A 0.03 A 0.02 A	1.5 A 1.5 A 0.5 A 0.03 A 0.02 A

Z-01H

Rated voltage	Resistive load	
	NC	NO
125 VAC	0.1 A	
8 VDC	0.1 A	
14 VDC	0.1 A	
30 VDC	0.1 A	

Z-10F

Model	Rated voltage	Non-inductive load				Inductive load			
		Resistive load		Lamp load		Inductive load		Motor load	
		NC	NO	NC	NO	NC	NO	NC	NO
Series connection	125 VAC	10 A		4 A	2 A	6 A		5 A	2.5 A
	250 VAC	10 A		2.5 A	1.5 A			3 A	1.5 A
	30 VDC	10 A		4 A	2 A	6 A		6 A	3 A
	125 VDC	1 A		1 A	1 A	0.1 A		0.1 A	0.1 A
Parallel connection	250 VDC	0.6 A		0.6 A	0.6 A	0.05 A		0.05 A	0.05 A
	125 VAC	6 A		3 A	1.5 A	4 A		4 A	2 A
	250 VAC	6 A		2.5 A	1.25 A	4 A		2 A	1 A
	30 VDC	6 A		4 A	2 A	4 A		6 A	3 A
	125 VDC	0.6 A		0.6 A	0.6 A	0.1 A		0.1 A	0.1 A
	250 VDC	0.3 A		0.3 A	0.3 A	0.05 A		0.05 A	0.05 A

- Note:**
- The above current ratings are the values of the steady-state current.
 - Inductive load has a power factor of 0.4 min. (AC) and a time constant of 7 ms max. (DC).
 - Lamp load has an inrush current of 10 times the steady-state current.
 - Motor load has an inrush current of 6 times the steady-state current.
 - The normally closed and normally open ratings of reverse hinge lever models are opposite to each other.
 - The AC ratings of molded terminals are 125 and 250 V only.
 - The ratings values apply under the following test conditions:
 Ambient temperature: 20±2°C
 Ambient humidity: 65±5%
 Operating frequency: 20 operations/min

■ Characteristics

Item	Basic (except micro load and flexible rod)/ maintained contact Z-15	Basic (micro load) Z-01H	Basic (flexible rod) Z-15	Split-contact Z-10F
Operating speed (see note)	0.01 mm to 1 m/s (see note 1)		1 mm to 1 m/s	0.1 mm to 1 m/s (see note 1)
Operating frequency	Mechanical: 240 operations/min Electrical: 20 operations/min		Mechanical: 120 operations/min Electrical: 20 operations/min	Mechanical: 240 operations/min Electrical: 20 operations/min
Insulation resistance	100 MΩ min. (at 500 VDC)			
Contact resistance	15 mΩ max. (initial value)	50 mΩ max. (initial value)	15 mΩ max. (initial value)	25 mΩ max. (initial value)
Dielectric strength	<u>Between contacts of same polarity</u> Contact gap G: 1,000 VAC, 50/60 Hz for 1 min Contact gap H: 600 VAC, 50/60 Hz for 1 min Contact gap E: 1,500 VAC, 50/60 Hz for 1 min <u>Between current-carrying metal parts and ground, and between each terminal and non-current-carrying metal parts</u> 2,000 VAC, 50/60 Hz for 1 min		<u>Between contacts of same polarity</u> Contact gap G: 1,000 VAC, 50/60 Hz for 1 min Contact gap H: 600 VAC, 50/60 Hz for 1 min <u>Between current-carrying metal parts and ground, and between each terminal and non-current-carrying metal parts</u> 2,000 VAC, 50/60 Hz for 1 min	
Vibration resistance	Malfunction: 10 to 55 Hz, 1.5-mm double amplitude (see note 5)		Malfunction: 10 to 20 Hz, 1.5-mm double amplitude (see note 5)	Malfunction: 10 to 55 Hz, 1.5-mm double amplitude (see note 5)
Shock resistance	<u>Destruction:</u> 1,000 m/s ² {approx. 100G} max. <u>Malfunction:</u> 300 m/s ² {approx. 30G} max. (see note 2, 5)		<u>Destruction:</u> 1,000 m/s ² {approx. 100G} max. <u>Malfunction:</u> 50 m/s ² {approx. 5G} max. (see note 5)	
Durability	<u>Mechanical:</u> Contact gap G, H: 20,000,000 operations min. (see note 4) Contact gap E: 300,000 operations <u>Electrical:</u> Contact gap G, H: 500,000 operations min. Contact gap E: 100,000 operations min.		<u>Mechanical:</u> 1,000,000 operations min. <u>Electrical:</u> 100,000 operations min.	
Degree of protection	General-purpose: IP00 Drip-proof: IP62			
Degree of protection against electric shock	Class I			
Proof tracking index (PTI)	175			
Switch category	D (IEC335-1)			
Ambient temperature	Operating: General-purpose: -25°C to 80°C (with no icing) Drip-proof: -15°C to 80°C (with no icing)			
Ambient humidity	Operating: General-purpose: 35% to 85% Drip-proof: 35% to 95%			
Weight	Approx. 22 to 58 g		Approx. 42 to 48 g	Approx. 34 to 61 g

- Note:** 1. The values are for the plunger models. (For the lever models, the values are at the plunger section.) (Contract your OMRON representative for other models.)
 2. The values are for the Z-15G pin plunger.
 3. The values are for the Z-10FY-B.
 4. The values are for the pin plunger. The durability for models other than the pin plunger is 10,000,000 min.
 5. Malfunction: 1 ms max.

■ Contacts Specification

Item		Z-15	Z-01H	Z-10F
Contacts	Shape	Rivet	Single crossbar	Rivet
	Material	Silver alloy	Gold alloy	Silver alloy
Inrush current	NC	30 A max.	0.1 A max.	40 A max.
	NO	15 A max.	0.1 A max.	20 A max.

■ Contact Form

Basic Models

General-purpose

Contact Form (SPDT)

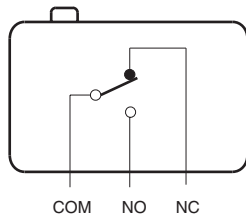

Note: The Z-15GM is a reversible model and the NO and NC positions are reversed.

Split-contact Models

Contact Form (Split-contact)

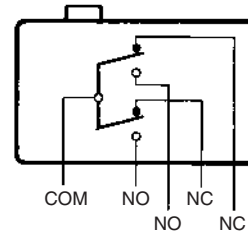

Connection Example

Series Connection Parallel Connection

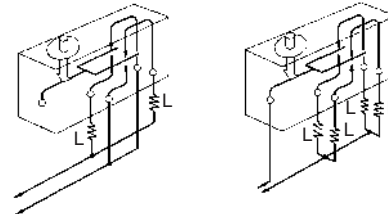

Maintained-contact Models

Contact Form (Maintained-contact)

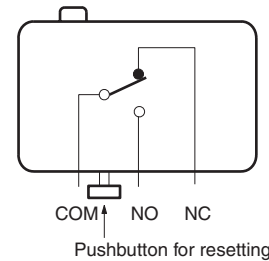

Engineering Data

■ Mechanical Durability

Z-15G

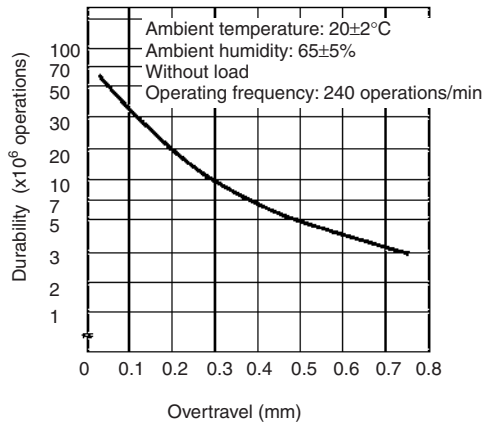

■ Electrical Durability

Z-15G

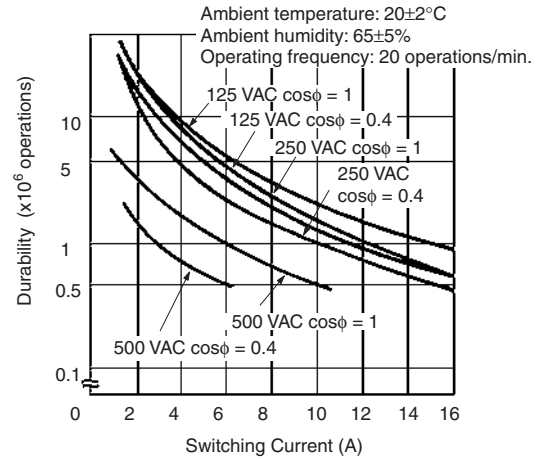

Nomenclature

■ Drip-proof Construction

Without Terminal Protective Cover

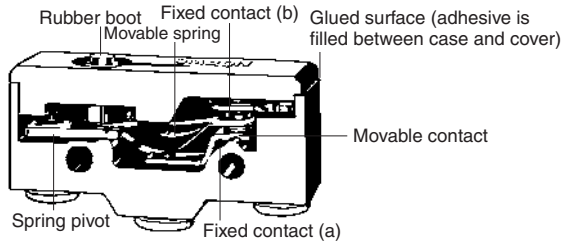

With Terminal Protective Cover

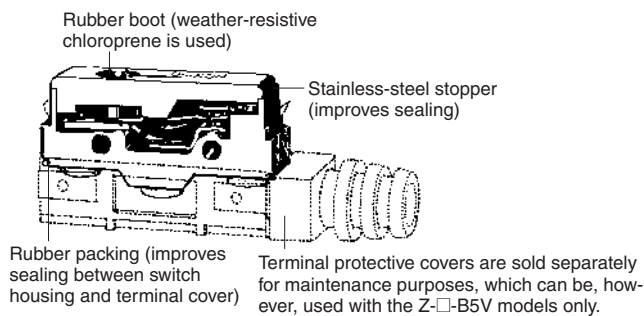

Dimensions

- Note:** 1. Unless otherwise indicated, all units are in millimeters.
 2. Unless otherwise specified, a tolerance of ± 0.4 mm applies to all dimensions.

■ Dimensions and Operating Characteristics

Basic Models (General-purpose) & Split-contact Models

The models, illustrations, and graphics are for screw-terminal models (-B). The "-A" at the end of the model number for solder terminal models has been omitted. For details of the terminals, refer to *Terminals* above.

Pin Plunger

Z-15G-B, Z-15E-B
 Z-15H-B, Z-01H-B
 Z-10FY-B

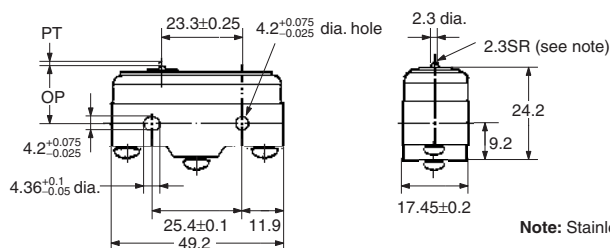
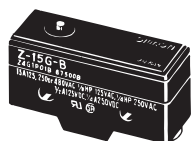

Note: Stainless-steel plunger

	Z-15G-B	Z-15H-B	Z-15E-B	Z-01H-B	Z-10FY-B
OF	2.45 to 3.43 N {250 to 350 gf}	1.96 to 2.75 N {200 to 280 gf}	6.12 to 7.85 N {625 to 800 gf}	2.45 N {250 gf} max.	4.46 to 7.26 N {455 to 740 gf}
RF min.	1.12 N {114 gf}	1.12 N {114 gf}	1.12 N {114 gf}	0.78 N {80 gf}	1.12 N {114 gf}
PT max.	0.4 mm	0.3 mm	0.8 mm	0.5 mm	0.8 mm
OT min.	0.13 mm	0.13 mm	0.13 mm	0.13 mm	0.13 mm
MD max.	0.05 mm	0.025 mm	0.13 mm	0.04 mm	0.1 mm
OP	15.9±0.4 mm				

Slim Spring Plunger

Z-15GS-B, Z-15HS-B,
 Z-01HS-B, Z-10FSY-B

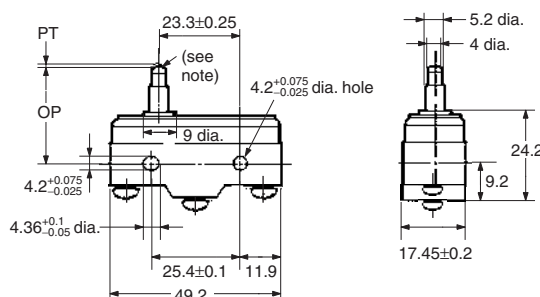
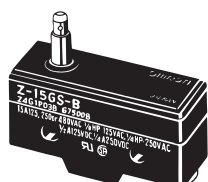

Note: Stainless-steel plunger
 (flat, 1R chamfered)

	Z-15GS-B	Z-15HS-B	Z-01HS	Z-10FSY-B
OF	2.45 to 3.43 N {250 to 350 gf}	1.96 to 2.79 N {200 to 285 gf}	2.45 N {250 gf} max.	4.46 to 7.26 N {455 to 740 gf}
RF min.	1.12 N {114 gf}	1.12 N {114 gf}	0.78 N {80 gf}	1.12 N {114 gf}
PT max.	0.4 mm	0.3 mm	0.5 mm	0.8 mm
OT min.	1.6 mm	1.6 mm	1.6 mm	1.6 mm
MD max.	0.05 mm	0.025 mm	0.05 mm	0.1 mm
OP	28.2±0.5 mm			

Short Spring Plunger

Z-15GD-B, Z-01HD-B
Z-15HD-B, Z-10FDY-B
Z-15ED-B

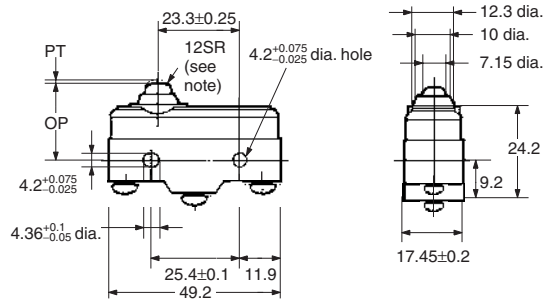
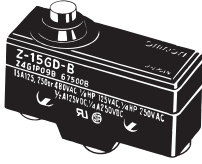

Note: Plated iron plunger

	Z-15GD-B	Z-15HD-B	Z-15ED-B	Z-01HD-B	Z-10FDY-B
OF	2.45 to 3.43 N {250 to 350 gf}	1.96 to 2.79 N {200 to 285 gf}	6.13 to 7.85 N {625 to 800 gf}	2.45 N {250 gf} max.	4.46 to 7.26 N {455 to 740 gf}
RF min.	1.12 N {114 gf}	1.12 N {114 gf}	1.12 N {114 gf}	0.78 N {80 gf}	1.12 N {114 gf}
PT max.	0.4 mm	0.3 mm	0.8 mm	0.5 mm	0.8 mm
OT min.	1.6 mm	1.6 mm	1.6 mm	1.6 mm	1.6 mm
MD max.	0.05 mm	0.025 mm	0.13 mm	0.05 mm	0.1 mm
OP	21.5±0.5 mm				

Panel Mount Plunger

Z-15GQ-B, Z-01HQ-B
Z-15HQ-B, Z-10FQY-B
Z-15EQ-B

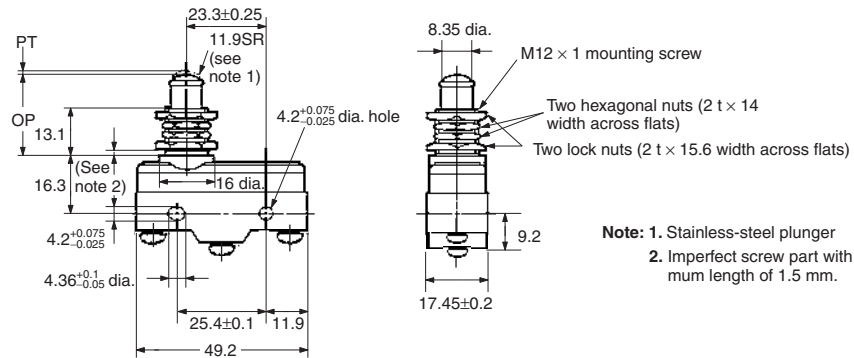
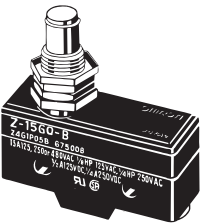

Note: 1. Stainless-steel plunger
2. Imperfect screw part with a maximum length of 1.5 mm.

Z-15GQ3-B

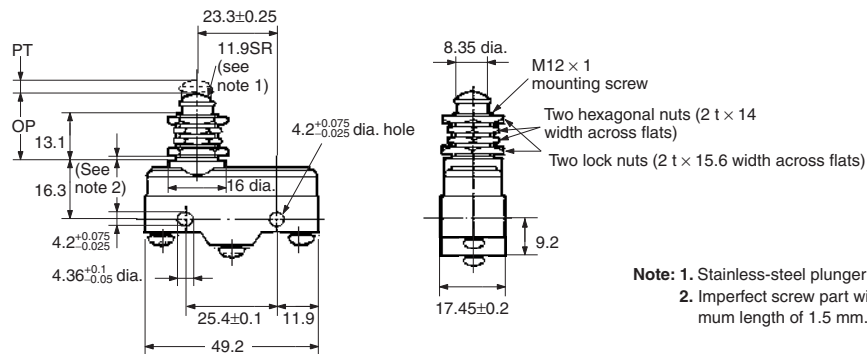
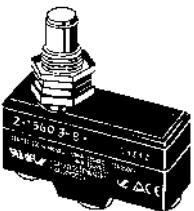

Note: 1. Stainless-steel plunger
2. Imperfect screw part with a maximum length of 1.5 mm.

Z-15GQ8-B

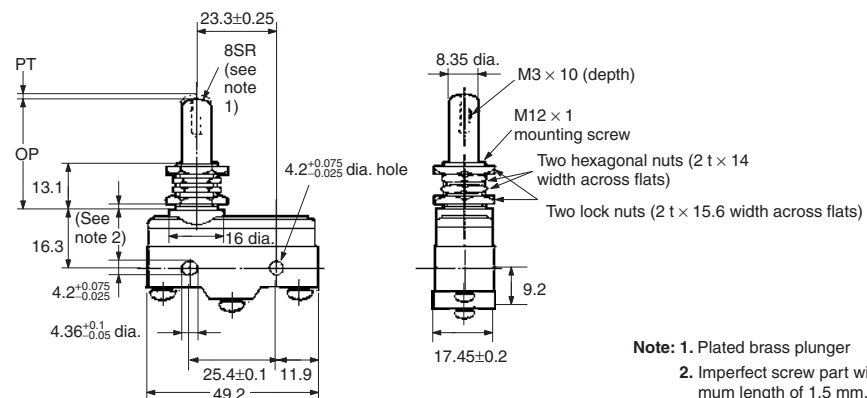
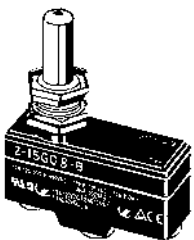

Note: 1. Plated brass plunger
2. Imperfect screw part with a maximum length of 1.5 mm.

	Z-15GQ-B	Z-15HQ-B	Z-15EQ-B	Z-01HQ-B	Z-10FQY-B	Z-15GQ3-B	Z-15GQ8-B
OF	2.45 to 3.43 N {250 to 350 gf}	1.96 to 2.79 N {200 to 285 gf}	6.13 to 7.85 N {625 to 800 gf}	2.45 N {250 gf} max.	4.46 to 7.26 N {455 to 740 gf}	2.45 to 3.43 N {250 to 350 gf}	2.45 to 3.43 N {250 to 350 gf}
RF min.	1.12 N {114 gf}	1.12 N {114 gf}	1.12 N {114 gf}	0.78 N {80 gf}	1.12 N {114 gf}	1.12 N {114 gf}	1.12 N {114 gf}
PT max.	0.4 mm	0.3 mm	0.8 mm	0.5 mm	0.8 mm	4.2 mm	0.5 mm
OT min.	5.5 mm	5.5 mm	5.5 mm	5.5 mm	5.5 mm	2.5 mm	5.5 mm
MD max.	0.05 mm	0.025 mm	0.13 mm	0.05 mm	0.1 mm	2.2 mm	0.05 mm
OP	21.8±0.8 mm					18.8±0.8 mm	32.5±1 mm

- Note:**
- Do not use the M12 mounting screw and the case mounting hole at the same time, or excessive pulling force will be imposed on the Switch and the case and cover may be damaged.
 - On the model Z-15GQ3-B, PT can be set to a value larger than that for the Z-15GQ.
 - On the model Z-15GQ8-B, operating position can be adjusted by providing a screw in the plunger section. The M3 hole with a depth of 10 mm is a through hole. Take precautions so that no water or screw lock agent penetrates into the hole.

Panel Mount Roller Plunger

Z-15GQ22-B, Z-15EQ22-B
Z-15HQ22-B, Z-10FQ22Y-B

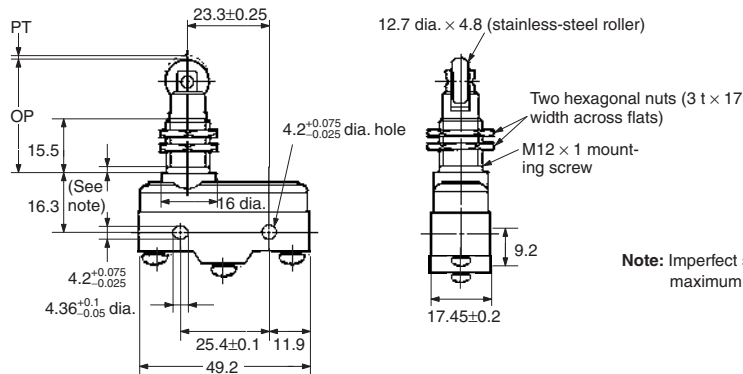
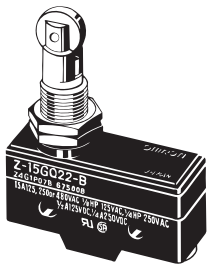

Note: Imperfect screw part with a maximum length of 1.5 mm.

	Z-15GQ22-B	Z-15HQ22-B	Z-15EQ22-B	Z-10FQ22Y-B
OF	2.45 to 3.43 N {250 to 350 gf}	1.96 to 2.79 N {200 to 285 gf}	6.13 to 7.85 N {625 to 800 gf}	4.46 to 7.26 N {455 to 740 gf}
RF min.	1.12 N {114 gf}	1.12 N {114 gf}	1.12 N {114 gf}	1.12 N {114 gf}
PT max.	0.4 mm	0.3 mm	0.8 mm	1 mm
OT min.	3.58 mm	3.58 mm	3.58 mm	3.55 mm
MD max.	0.05 mm	0.025 mm	0.13 mm	0.1 mm
OP	33.4±1.2 mm			

Note: Do not use the M12 mounting screw and the case mounting hole at the same time, or the case may be damaged.

Panel Mount Cross Roller Plunger

Z-15GQ21-B, Z-15HQ21-B,
Z-15EQ21-B

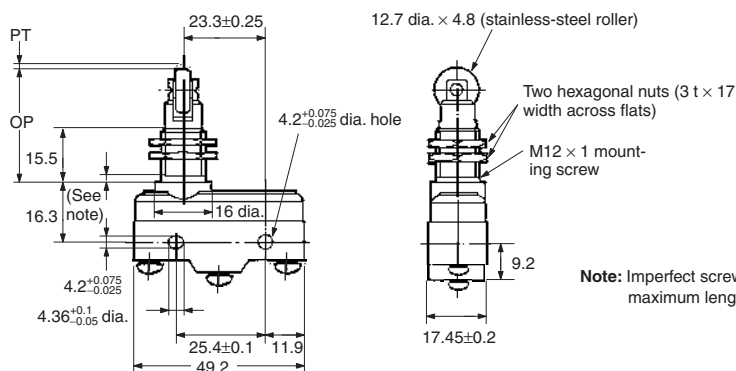
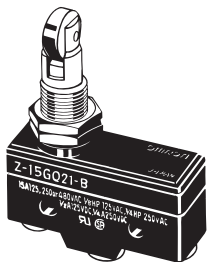

Note: Imperfect screw part with a maximum length of 1.5 mm.

	Z-15GQ21-B	Z-15HQ21-B	Z-15EQ21-B
OF	2.45 to 3.43 N {250 to 350 gf}	1.96 to 2.79 N {200 to 285 gf}	6.13 to 7.85 N {625 to 800 gf}
RF min.	1.12 N {114 gf}	1.12 N {114 gf}	1.12 N {114 gf}
PT max.	0.4 mm	0.3 mm	0.8 mm
OT min.	3.58 mm	3.58 mm	3.58 mm
MD max.	0.05 mm	0.025 mm	0.13 mm
OP	33.4±1.2 mm		

Note: Do not use the M12 mounting screw and the case mounting hole at the same time, or the case may be damaged.

Leaf Spring

Z-15GL-B

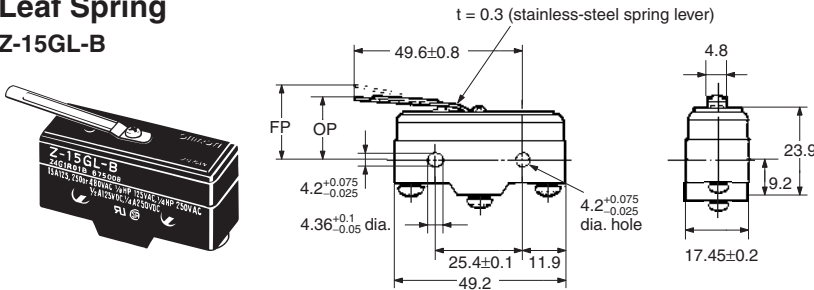

OF max.	1.38 N {141 gf}
RF min.	0.14 N {14 gf}
OT min.	1.6 mm (see note)
MD max.	1.3 mm
FP max.	20.6 mm
OP	17.4±0.8 mm

Note: When operating, be sure not to exceed 1.6 mm.

Roller Leaf Spring

Z-15GL2-B

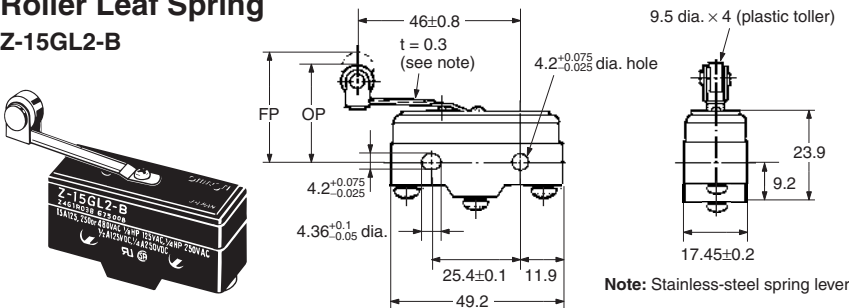

OF max.	1.38 N {141 gf}
RF min.	0.14 M {14 gf}
OT min.	1.6 mm (see note)
MD max.	1.3 mm
FP max.	31.8 mm
OP	28.6±0.8 mm

Note: When operating, be sure not to exceed 1.6 mm.

Short Hinge Lever

Z-15GW21-B

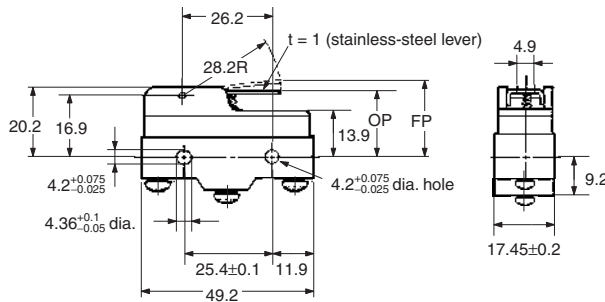
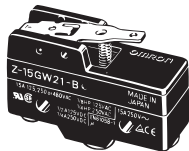

OF max.	1.57 N {160 gf}
RF min.	0.27 N {28 gf}
OT min.	2 mm
MD max.	1 mm
FP max.	24.8 mm
OP	19±0.8 mm

Hinge Lever

Z-15GW-B, Z-15GW32-B

Z-15HW-B, Z-10FWY-B

Z-15GW3-B (Lever Length: 56R)

(see note)

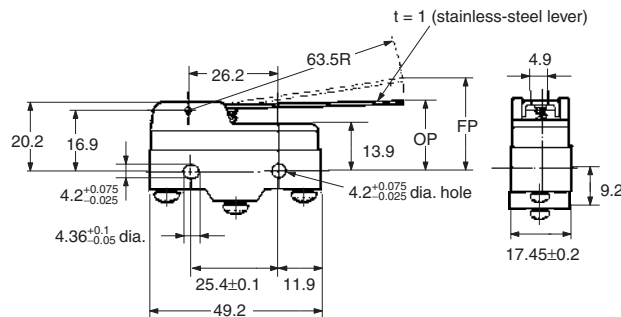
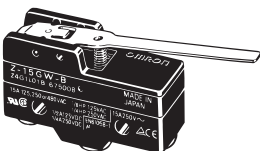

Note: The external dimensions of the actuator vary.

	Z-15GW-B	Z-15HW-B	Z-15GW32-B	Z-10FWY-B	Z-15GW3-B
OF max.	0.69 N {70 gf}	0.66 N {67 gf}	1.47 to 1.96 N {150 to 200 gf}	0.88 N {90 gf}	0.78 N {80 gf}
RF min.	0.14 N {14 gf}	0.14 N {14 gf}	0.92 N {94 gf}	0.14 N {14 gf}	0.15 N {15.5 gf}
OT min.	5.6 mm	5.6 mm	5.6 mm	5.6 mm	4.8 mm
MD max.	1.27 mm	0.63 mm	1.27 mm	2.4 mm	1.12 mm
FP max.	28.2 mm	27.4 mm	28.2 mm	29.8 mm	27.2 mm
OP	19±0.8 mm				

Low-force Hinge Lever

Z-15GW4-B

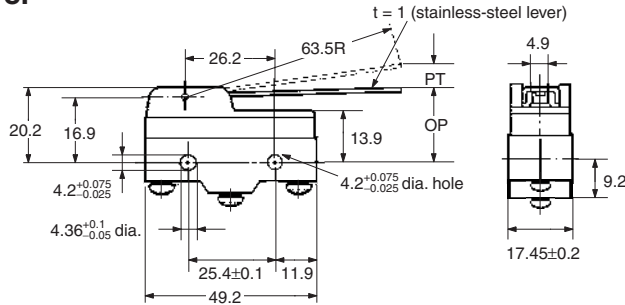
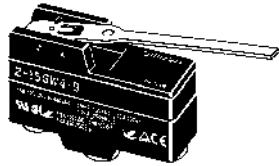

OF max.	274 mN {28 gf}
RF min.	34.3 mN {3.5 gf}
PT max.	10 mm
OT min.	5.6 mm
MD max.	1.27 mm
OP	19±0.8 mm

Z-15HW24-B

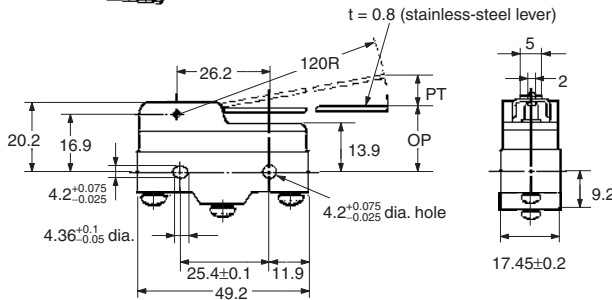
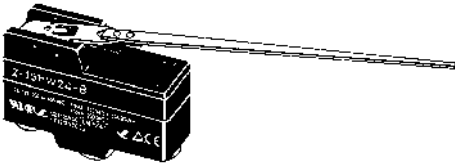

OF max.	58.8 mN {6 gf}
RF min.	4.90 mN {0.5 gf}
PT max.	19.8 mm
OT min.	10 mm
MD max.	2 mm
OP	19.8±1.6 mm

Low-force Wire Hinge Lever

Z-15HW52-B

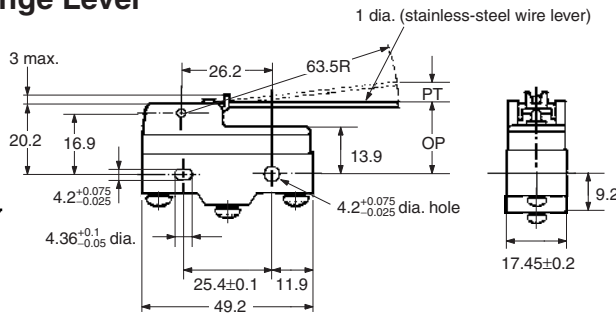
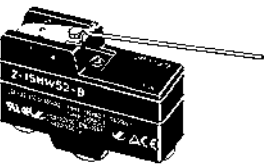

OF max.	58.8 mN {6 gf}
RF min.	4.90 mN {0.5 gf}
PT max.	8.3 mm
OT min.	5.6 mm
MD max.	0.65 mm
OP	19±1 mm

Z-15HW78-B

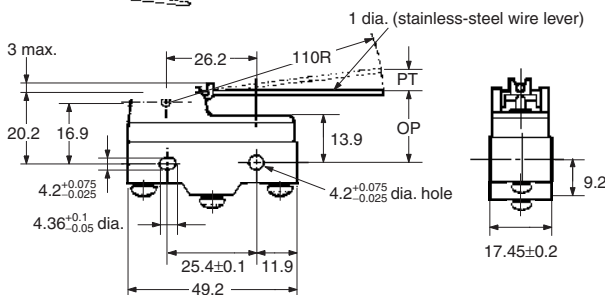
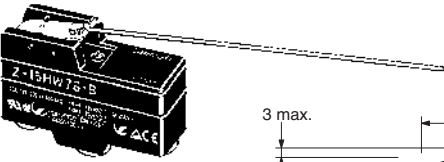

OF max.	39.2 mN {4 gf}
RF min.	2.94 mN {0.3 gf}
PT max.	10 mm
OT min.	6 mm
MD max.	3 mm
OP	20±1 mm

Short Hinge Roller Lever

Z-15GW22-B, Z-01HW22-B
 Z-15HW22-B, Z-10FW22Y-B (see note)
 Z-15EW22-B, Z-15GW2-B
 Z-15HW2-B (see note), Z-10FW2Y-B (see note)
 (Lever Length: 48.5R) (see note)

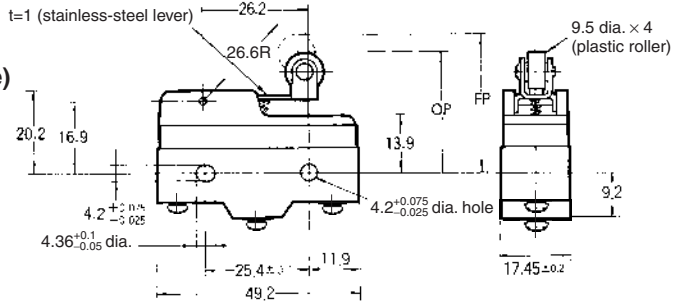
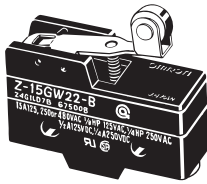

Note: The external dimensions of the actuator vary.

	Z-15GW22-B	Z-15HW22-B	Z-15EW22-B	Z-01HW22-B	Z-10FW22Y-B	Z-15GW2-B	Z-15HW2-B	Z-10FW2Y-B
OF max.	1.57 N {160 gf}	1.47 N {150 gf}	1.94 N {198 gf}	1.57 N {160 gf}	2.45 N {250 gf}	0.98 N {100 gf}	0.84 N {86 gf}	1.27 N {130 gf}
RF min.	0.41 N {42 gf}	0.41 N {42 gf}	0.41 N {42 gf}	0.27 N {28 gf}	0.34 N {35 gf}	0.22 N {22 gf}	0.22 N {22 gf}	0.22 N {22 gf}
OT min.	2.4 mm	2.4 mm	2.4 mm	2.4 mm	2.4 mm	4 mm	4 mm	4 mm
MD max.	0.5 mm	0.45 mm	1.3 mm	0.5 mm	1 mm	1.02 mm	0.6 mm	2 mm
FP max.	32.5 mm		35.1 mm	32.5 mm	34.8 mm	36.5 mm		37.4 mm
OP	30.2±0.4 mm		30.2±0.4 mm	30.2±0.4 mm	30.2±0.4 mm	30.2±0.8 mm		30.2±0.8 mm

Short Hinge Cross Roller Lever

Z-15GW49-B
 Z-15GW54-B (Lever Length: 48.7R)
 (see note)

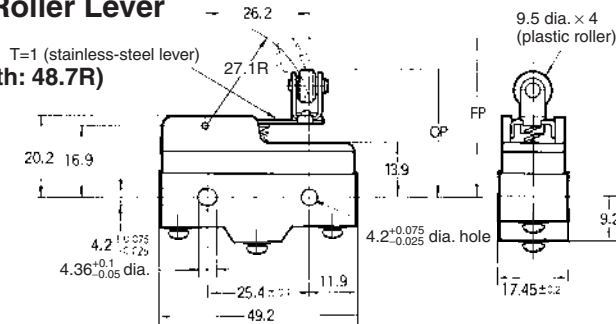

Model	Z-15GW49-B	Z-15GW54-B
OF max.	1.67 N {170 gf}	0.98 N {100 gf}
RF min.	0.41 N {42 gf}	0.22 N {22 gf}
OT min.	2.4 mm	4 mm
MD max.	0.51 mm	1 mm
FP max.	33.3 mm	37.3 mm
OP	31±0.4 mm	31±0.8 mm

Note: The external dimensions of the actuator vary.

Z-15GW25-B

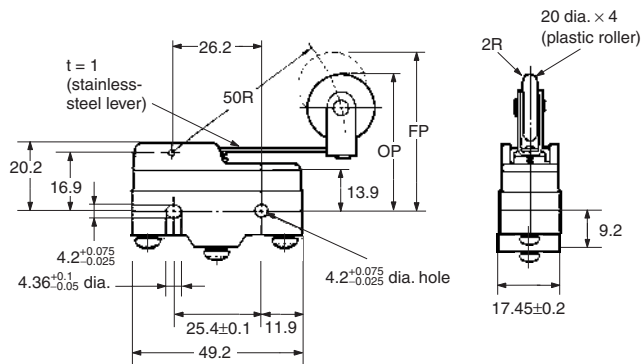
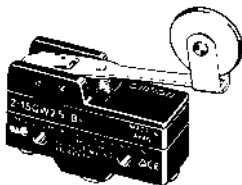

OF max.	0.98 N {100 gf}
RF min.	0.21 N {21 gf}
OT min.	4 mm
MD max.	1.6 mm
FP max.	47.5 mm
OP	41.2±0.8 mm

Unidirectional Short Hinge Roller Lever

Z-15GW2277-B

OF max.	1.67 N {170 gf}
RF min.	0.41 N {42 gf}
OT min.	2.4 mm
MD max.	0.51 mm
FP max.	43.6 mm
OP	41.3±0.8 mm

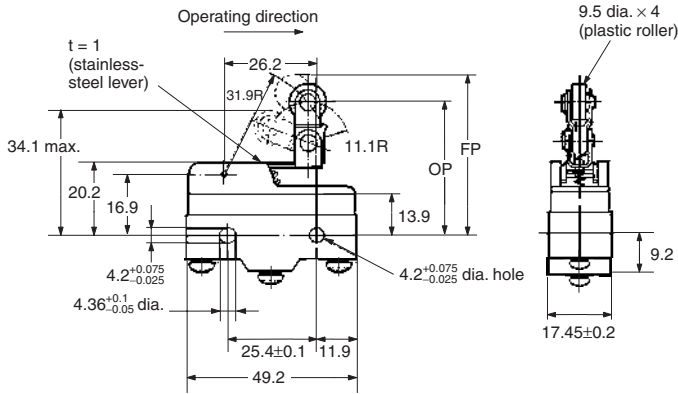
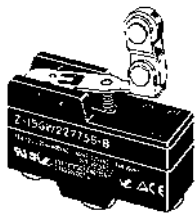

Reverse Hinge Lever

Note: The pin plungers of reverse-type models are continuously pressed by the actuator levers with compression coil springs and the pin plungers are freed by operating the levers. Reverse-type models are highly vibration- and shock-resistant because the pin plungers are normally pressed.

Z-15GM-B

OF max.	1.67 N {170 gf}
RF min.	0.27 N {28 gf}
OT min.	5.6 mm
MD max.	0.89 mm
FP max.	23.8 mm
OP	19±0.8 mm

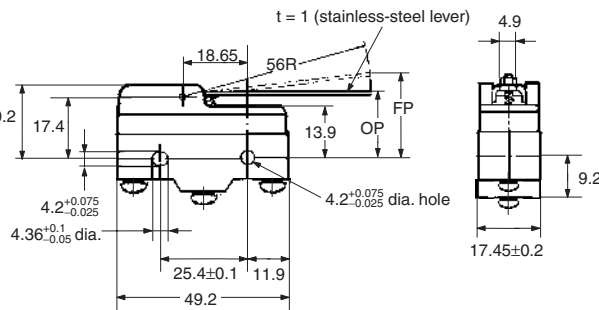
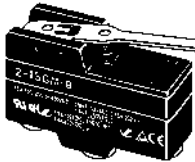

Reverse Short Hinge Roller Lever

Note: The pin plungers of reverse-type models are continuously pressed by the actuator levers with compression coil springs and the pin plungers are freed by operating the levers. Reverse-type models are highly vibration- and shock-resistant because the pin plungers are normally pressed.

Z-15GM22-B,
Z-10FM22Y-B

Model	Z-15GM22-B	Z-10FM22Y-B
OF max.	5.28 N {538 gf}	6.37 N {650 gf}
RF min.	1.67 N {170 gf}	1.67 N {170 gf}
OT min.	2 mm	2 mm
MD max.	0.28 mm	0.56 mm
FP max.	31.8 mm	33 mm
OP	29.4±0.4 mm	29.4±0.4 mm

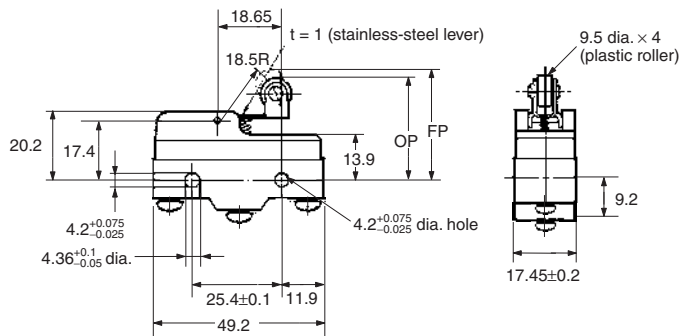
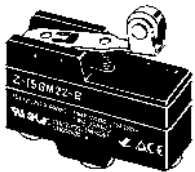

Reverse Hinge Roller Lever

Note: The pin plungers of reverse-type models are continuously pressed by the actuator levers with compression coil springs and the pin plungers are freed by operating the levers. Reverse-type models are highly vibration- and shock-resistive because the pin plungers are normally pressed.

Z-15GM2-B

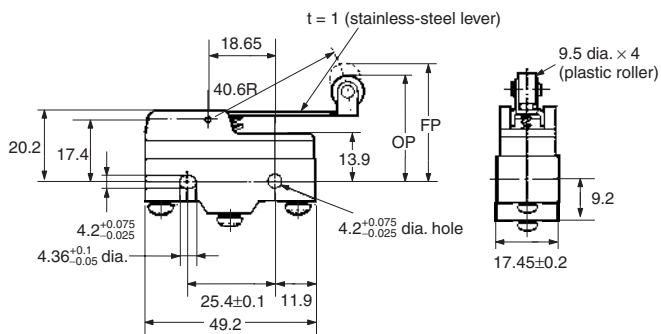
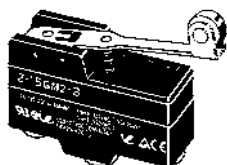

OF max.	2.35 N {240 gf}
RF min.	0.55 N {56 gf}
OT min.	4 mm
MD max.	0.64 mm
FP max.	35 mm
OP	30.2±0.8 mm

Basic Models (Drip-proof) without Terminal Protective Cover

Pin Plunger

Z-15G55-B
Z-01H55-B

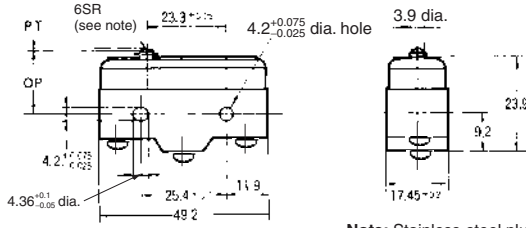
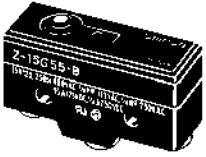

Note: Stainless-steel plunger

Model	Z-15G55-B	Z-01H55-B
OF	2.45 to 4.22 N {250 to 431 gf}	3.43 N {350 gf} max.
RF min.	1.12 N {114 gf}	0.78 N {80 gf}
PT max.	2.2 mm	2.2 mm
OT min.	0.13 mm	0.13 mm
MD max.	0.06 mm	0.06 mm
OP	15.9±0.4 mm	

Short Spring Plunger

Z-15GD55-B
Z-01HD55-B

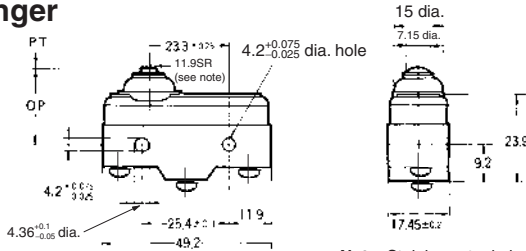
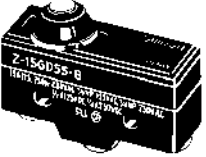

Note: Stainless-steel plunger

Model	Z-15GD55-B	Z-01HD55-B
OF max.	5.30 N {541 gf}	3.63 N {370 gf}
RF min.	1.12 N {114 gf}	0.78 N {80 gf}
PT max.	1.8 mm	1.9 mm
OT min.	1.6 mm	1.6 mm
MD max.	0.06 mm	0.06 mm
OP	21.5±0.5 mm	

Spring Plunger

Z-15GK55-B

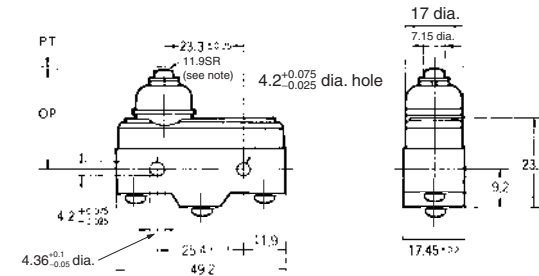
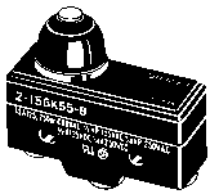

Note: Stainless-steel plunger

OF max.	5.30 N {541 gf}
RF min.	1.12 N {114 gf}
PT max.	2.3 mm
OT min.	1.6 mm
MD max.	0.06 mm
OP	28.2±0.5 mm

Z-15GK355-B

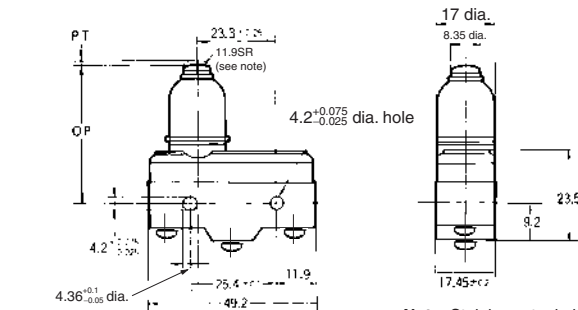
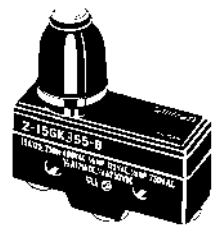

Note: Stainless-steel plunger

OF max.	5.30 N {541 gf}
RF min.	1.12 N {114 gf}
PT max.	2.4 mm
OT min.	3.5 mm
MD max.	0.06 mm
OP	37.8±1.2 mm

Panel Mount Plunger

Z-15GQ55-B

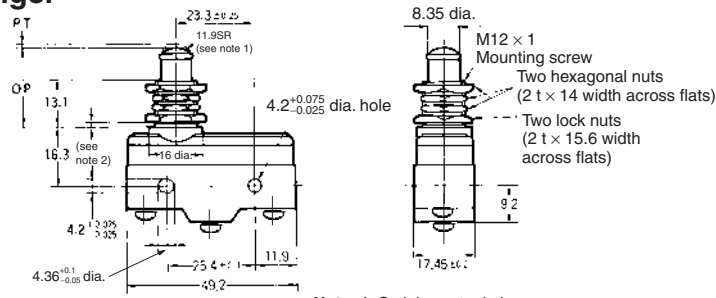
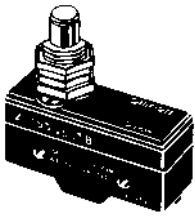

Note: 1. Stainless-steel plunger
2. Imperfect screw part with a maximum length of 1.5 mm.

OF max.	5.30 N {541 gf}
RF min.	1.12 N {114 gf}
PT max.	1.8 mm
OT min.	5.5 mm
MD max.	0.06 mm
OP	21.8 ± 0.8 mm

Note: Do not use the M12 mounting screw and the case mounting hole at the same time, or the case may be damaged.

Panel Mount Roller Plunger

Z-15GQ2255-B

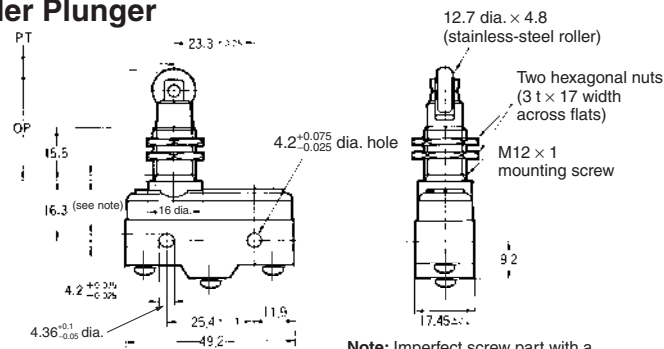
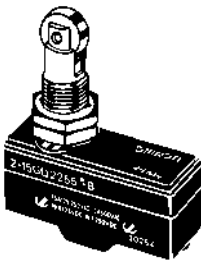

Note: Imperfect screw part with a maximum length of 1.5 mm.

OF max.	5.30 N {541 gf}
RF min.	1.12 N {114 gf}
PT max.	1.8 mm
OT min.	3.58 mm
MD max.	0.06 mm
OP	33.4 ± 1.2 mm

Note: Do not use the M12 mounting screw and the case mounting hole at the same time, or the case may be damaged.

Panel Mount Cross Roller Plunger

Z-15GQ2155-B

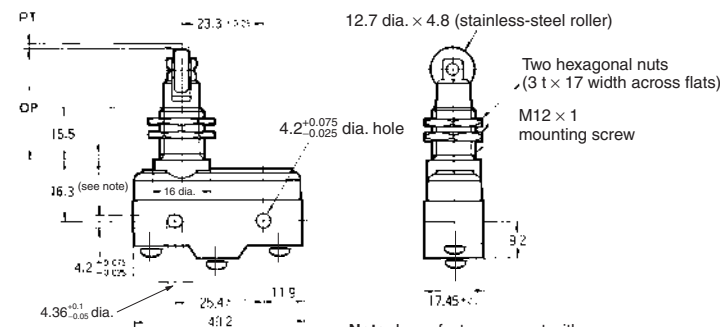
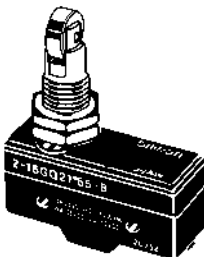

Note: Imperfect screw part with a maximum length of 1.5 mm.

OF max.	5.30 N {541 gf}
RF min.	1.12 N {114 gf}
PT max.	1.8 mm
OT min.	3.58 mm
MD max.	0.06 mm
OP	33.4 ± 1.2 mm

Note: Do not use the M12 mounting screw and the case mounting hole at the same time, or the case may be damaged.

Leaf Spring

Z-15GL55-B

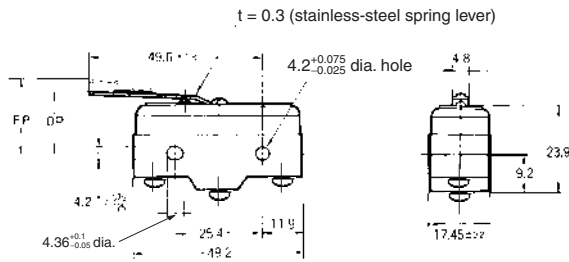
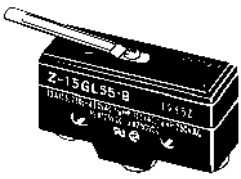

OF max.	1.96 N {200 gf}
RF min.	0.14 N {14 gf}
OT min.	1.6 mm
MD max.	1.3 mm
FP max.	20.6 mm
OP	17.5 ± 0.8 mm

Note: When operating, be sure not to exceed 1.6 mm.

Roller Leaf Spring

Z-15GL255-B

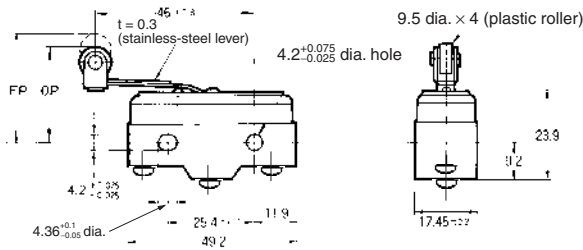
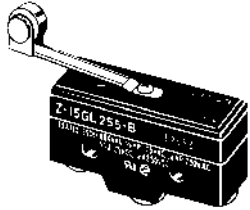

OF max.	1.96 N {200 gf}
RF min.	0.14 N {14 gf}
OT min.	1.6 mm
MD max.	1.3 mm
FP max.	31.8 mm
OP	28.6 ± 0.8 mm

Note: When operating, be sure not to exceed 1.6 mm.

Short Hinge Lever

Z-15GW2155-B

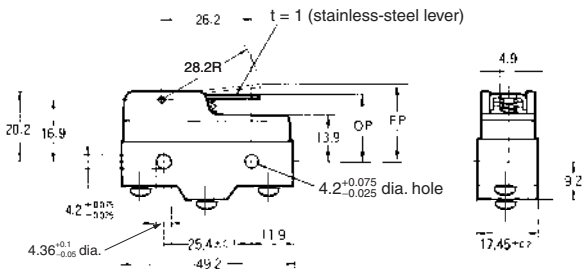
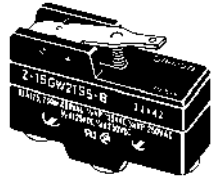

OF max.	1.86 N {190 gf}
RF min.	0.27 N {28 gf}
OT min.	2 mm
MD max.	1 mm
FP max.	25 mm
OP	19 ± 0.8 mm

Long Hinge Lever

Z-15GW4455-B

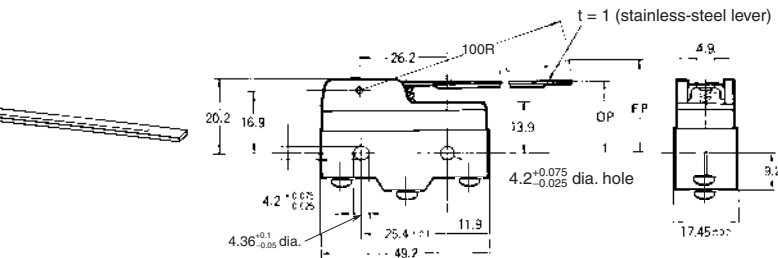
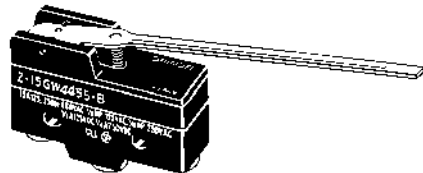

OF max.	0.88 N {90 gf}
RF min.	0.14 N {14 gf}
OT min.	5.6 mm
MD max.	3.5 mm
FP max.	33 mm
OP	19 ± 1.2 mm

Hinge Lever

Z-15GW55-B

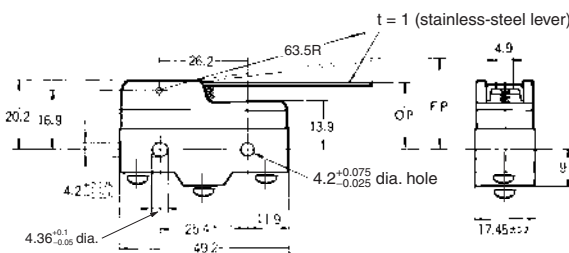
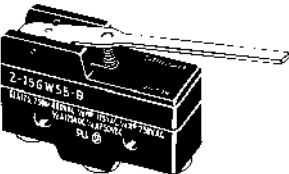

OF max.	0.98 N {100 gf}
RF min.	0.14 N {14 gf}
OT min.	5.6 mm
MD max.	2 mm
FP max.	28.2 mm
OP	19 ± 0.8 mm

Short Hinge Roller Lever

Z-15GW2255-B
Z-01HW2255-B

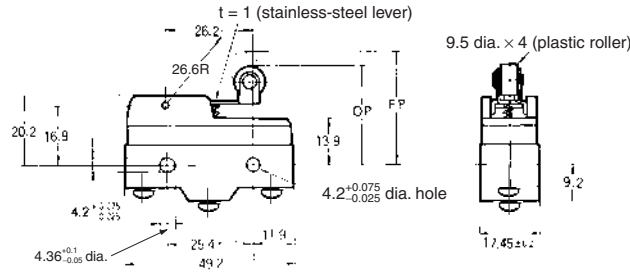
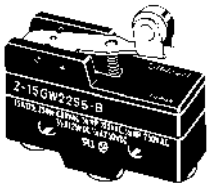

Model	Z-15GW2255-B	Z-01HW2255-B
OF max.	1.96 N {200 gf}	1.96 N {200 gf}
RF min.	0.41 N {42 gf}	0.27 N {28 gf}
OT min.	2.4 mm	2.4 mm
MD max.	0.8 mm	0.8 mm
FP max.	32.9 mm	
OP	30.2±0.4 mm	

Hinge Roller Lever

Z-15GW255-B

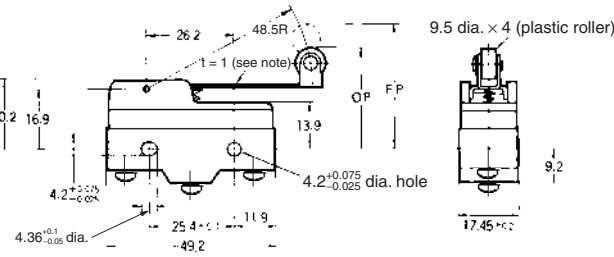
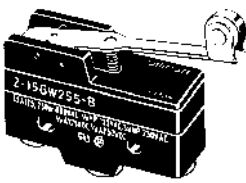

Note: Stainless-steel lever

OF max.	1.27 N {130 gf}
RF min.	0.21 N {21 gf}
OT min.	4 mm
MD max.	1.6 mm
FP max.	36.5 mm
OP	30.2±0.8 mm

Unidirectional Short Hinge Roller Lever

Z-15GW227755-B

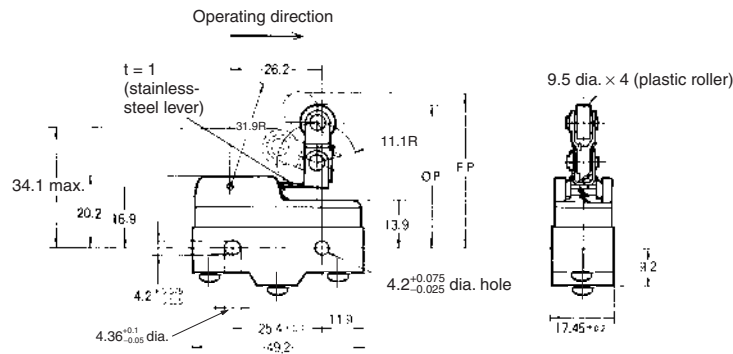

OF max.	1.77 N {181 gf}
RF min.	0.49 N {50 gf}
OT min.	2.4 mm
MD max.	0.8 mm
FP max.	43.6 mm
OP	41.3±0.8 mm

Reverse Hinge Lever

Note: The pin plungers of reverse-type models are continuously pressed by the actuator levers with compression coil springs and the pin plungers are freed by operating the levers. Reverse-type models are highly vibration- and shock-resistant because the pin plungers are normally pressed.

Z-15GM55-B

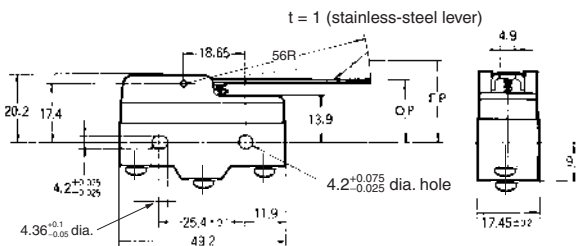
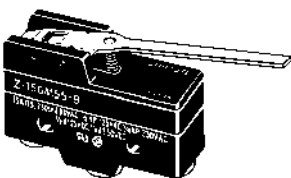

OF max.	1.96 N {200 gf}
RF min.	0.27 N {28 gf}
OT min.	5.6 mm
MD max.	0.89 mm
FP max.	23.8 mm
OP	19±0.8 mm

Reverse Short Hinge Roller Lever

Note: The pin plungers of reverse-type models are continuously pressed by the actuator levers with compression coil springs and the pin plungers are freed by operating the levers. Reverse-type models are highly vibration- and shock-resistant because the pin plungers are normally pressed.

Z-15GM2255-B

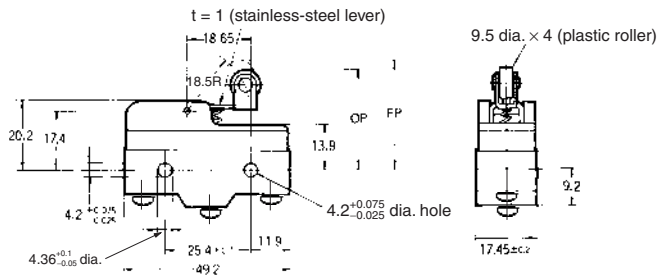
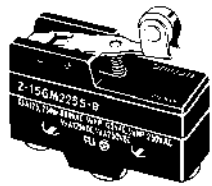

OF max.	5.69 N {581 gf}
RF min.	1.67 N {170 gf}
OT min.	2 mm
MD max.	0.28 mm
FP max.	31.8 mm
OP	29.4±0.4 mm

Reverse Hinge Roller Lever

Note: The pin plungers of reverse-type models are continuously pressed by the actuator levers with compression coil springs and the pin plungers are freed by operating the levers. Reverse-type models are highly vibration- and shock-resistant because the pin plungers are normally pressed.

Z-15GM255-B

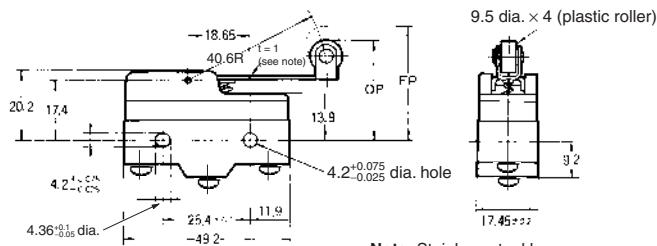
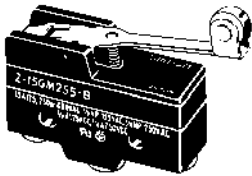

OF max.	2.65 N {270 gf}
RF min.	0.55 N {56 gf}
OT min.	4 mm
MD max.	0.64 mm
FP max.	35 mm
OP	30.2±0.8 mm

Flexible Rod (Coil Spring)

Z-15GNJ55-B

OF max.	0.49 N {50 gf}
PT max.	(20 mm)
OT	42 to 60 mm

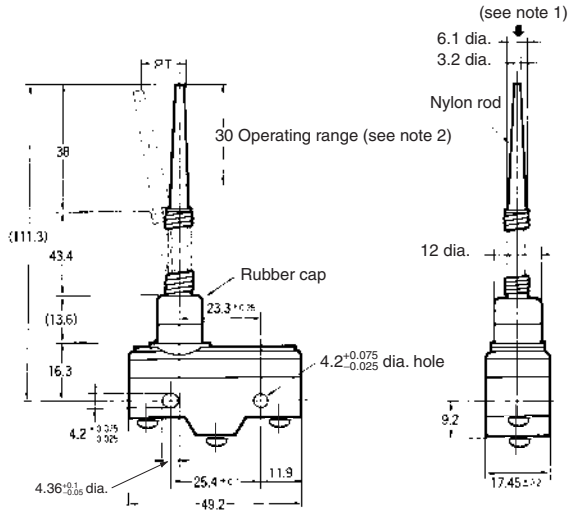
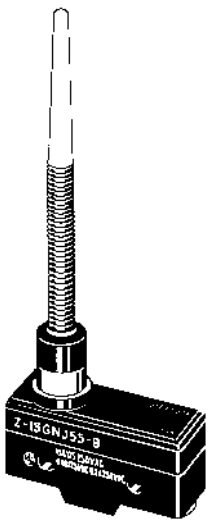

- Note:** 1. Operation is possible in any direction other than the axial direction (indicated by the arrow ↓).
 2. Use only the area within the top 30 mm of the rod as the operating part. (Do not use the area that falls within 80 mm from the mounting hole as the operating part. Using this area may cause damage to the nylon rod.)

Flexible Rod (Steel Wire)

Z-15HNJS55-B

OF max.	0.15 N {15 gf}
PT max.	(25 mm)

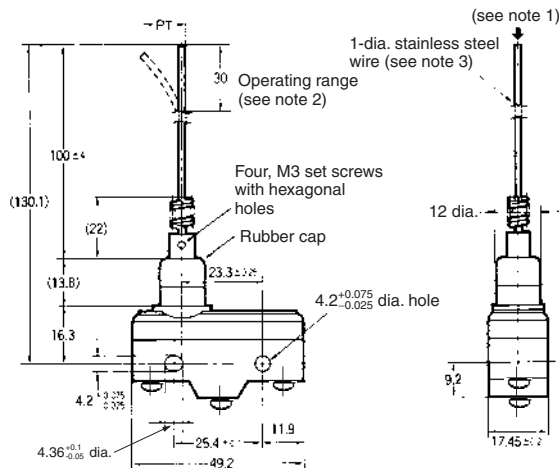
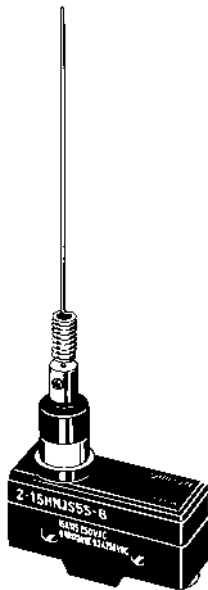

- Note:** 1. Operation is possible in any direction other than the axial direction (indicated by the arrow ↓).
 2. Use only the area within the top 30 mm of the rod as the operating part. (Do not use the area that falls within 100 mm from the mounting hole as the operating part. Using this area may cause damage to the steel wire.)
 3. The steel wire can be replaced if damaged. (Model: Lever for HNJS55)

Limit Switches

Basic Models (Drip-proof) with Terminal Protective Cover

Pin Plunger Z-15GA55-B5V

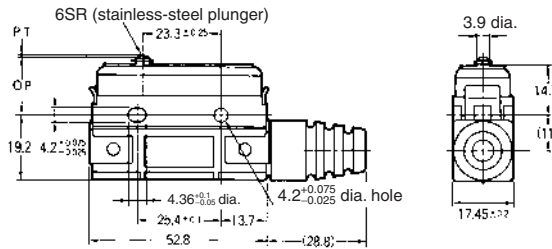
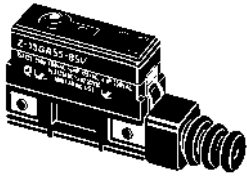

OF max.	2.45 to 4.22 N {250 to 431 gf}
RF min.	1.12 N {114 gf}
PT max.	2.2 mm
OT min.	0.13 mm
MD max.	0.06 mm
OP	15.9±0.4 mm

Z-15GK3A55-B5V

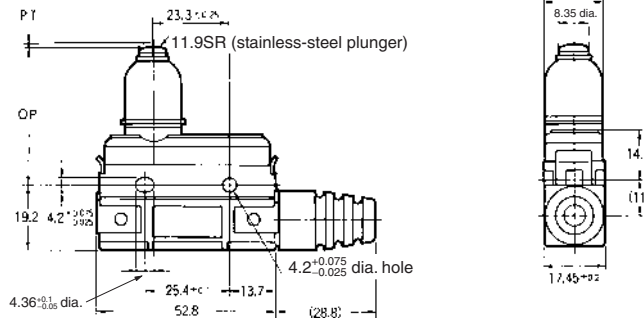
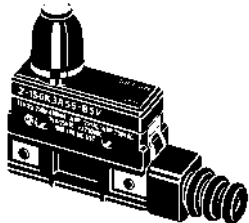

OF max.	5.30 N {541 gf}
RF min.	1.12 N {114 gf}
PT max.	2.4 mm
OT min.	3.5 mm
MD max.	0.06 mm
OP	37.8±1.2 mm

Panel Mount Plunger Z-15GQA55-B5V

Z-15GQA55-B5V

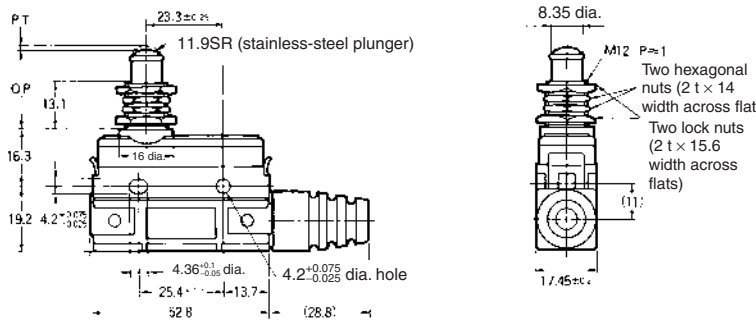
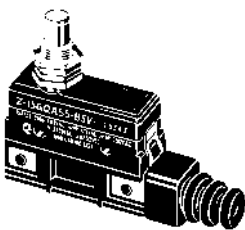

OF max.	5.30 N {541 gf}
RF min.	1.12 N {114 gf}
PT max.	1.8 mm
OT min.	5.5 mm
MD max.	0.06 mm
OP	21.8±0.8 mm

Note: Do not use the M12 mounting screw and the case mounting hole at the same time, or the case may be damaged.

Panel Mount Roller Plunger Z-15GQ22A55-B5V

Z-15GQ22A55-B5V

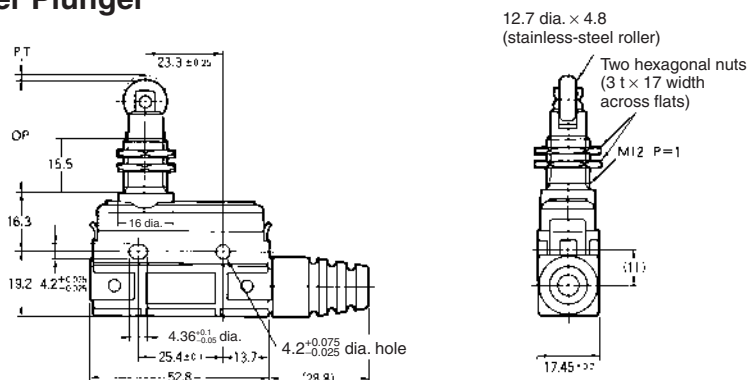
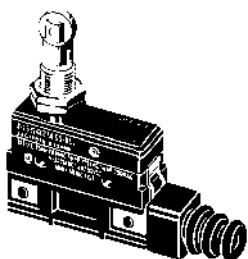

OF max.	5.30 N {541 gf}
RF min.	1.12 N {114 gf}
PT max.	1.8 mm
OT min.	3.58 mm
MD max.	0.06 mm
OP	33.4±1.2 mm

Note: Do not use the M12 mounting screw and the case mounting hole at the same time, or the case may be damaged.

Panel Mount Cross-roller Plunger

Z-15GQ21A55-B5V

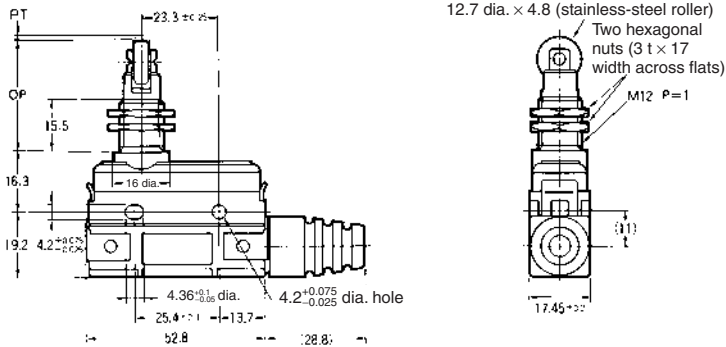
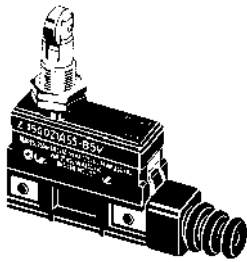

OF max.	5.30 N {541 gf}
RF min.	1.12 N {114 gf}
PT max.	1.8 mm
OT min.	3.58 mm
MD max.	0.06 mm
OP	33.4 ± 1.2 mm

Note: Do not use the M12 mounting screw and the case mounting hole at the same time, or the case may be damaged.

Long Hinge Lever

Z-15GW44A55-B5V

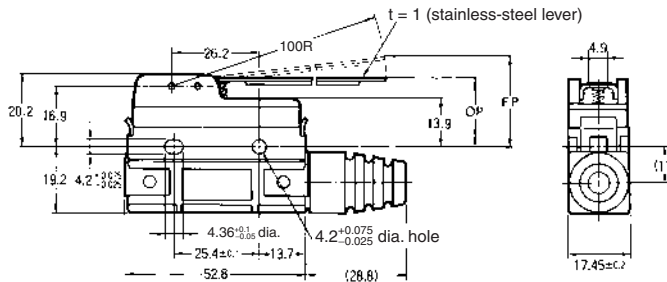
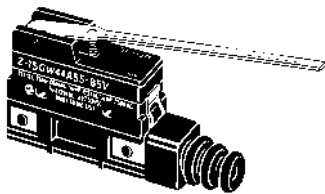

OF max.	0.88 N {90 gf}
RF min.	1.14 N {116 gf}
OT min.	5.6 mm
MD max.	3.5 mm
FP max.	33 mm
OP	19 ± 1.2 mm

Hinge Lever

Z-15GWA55-B5V

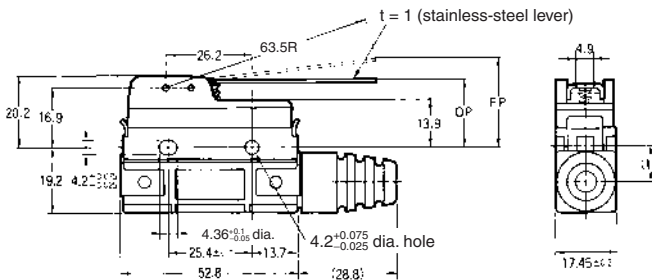
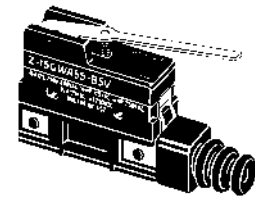

OF max.	0.98 N {100 gf}
RF min.	0.14 N {14 gf}
OT min.	5.6 mm
MD max.	2 mm
FP max.	28.2 mm
OP	19 ± 0.8 mm

Short Hinge Roller Lever

Z-15GW22A55-B5V

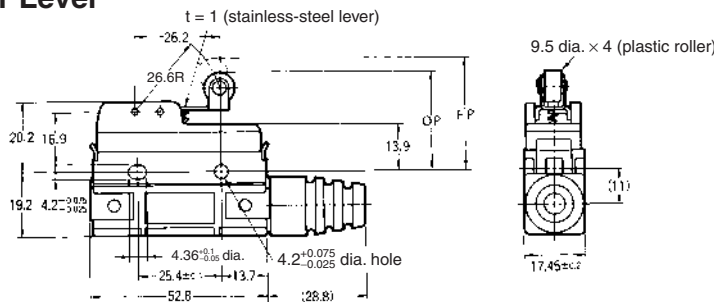
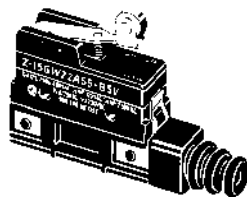

OF max.	1.96 N {200 gf}
RF min.	0.41 N {42 gf}
OT min.	2.4 mm
MD max.	0.8 mm
FP max.	32.9 mm
OP	30.2 ± 0.4 mm

Hinge Roller Lever

Z-15GW2A55-B5V

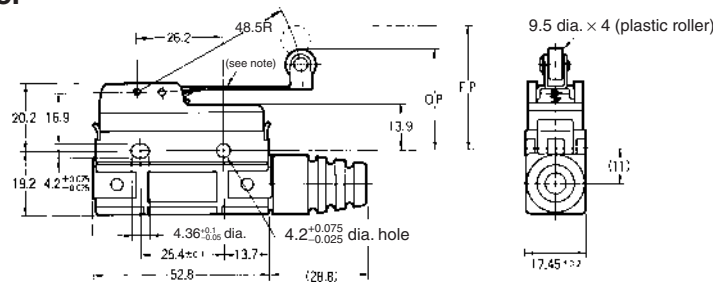
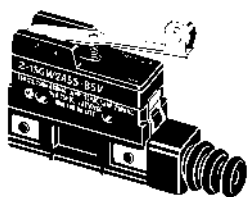

OF max.	1.27 N {130 gf}
RF min.	0.21 N {21 gf}
OT min.	4 mm
MD max.	1.6 mm
FP max.	36.5 mm
OP	30.2 ± 0.8 mm

Note: t = 1 (stainless-steel lever)

Unidirectional Short Hinge Roller Lever
Z-15GW2277A55-B5V

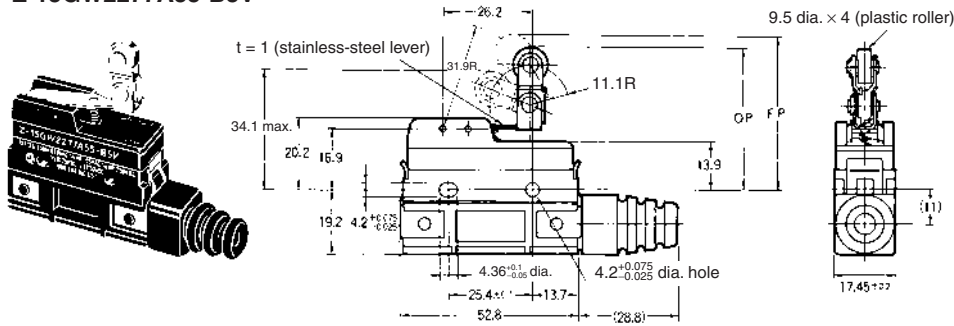

OF max.	1.77 N {181 gf}
RF min.	0.49 N {50 gf}
OT min.	2.4 mm
MD max.	0.8 mm
FP max.	43.6 mm
OP	41.3±0.8 mm

Maintained-contact Models

Pin Plunger
Z-15ER

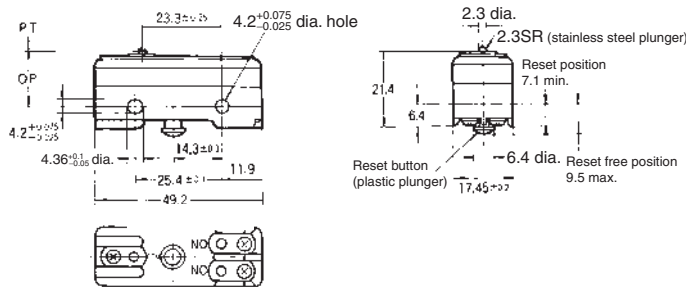

Plunger

OF max.	1.96 to 2.50 N {200 to 255 gf}
PT max.	0.4 mm
OT min.	0.13 mm
OP	15.9±0.4 mm

Reset Button

OF max.	0.55 to 2.79 N {56 to 285 gf}
OT min.	0.4 mm

Slim Spring Plunger
Z-15ESR

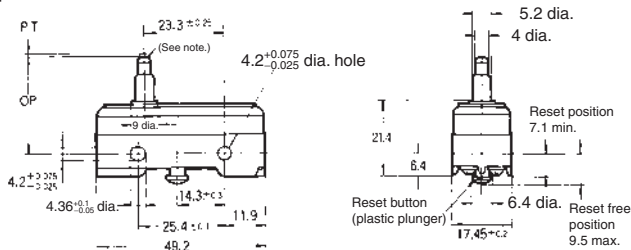
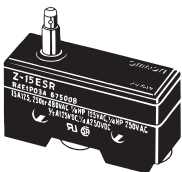

Note: Stainless steel plunger (tip only, flat, R1 bevel).

Plunger

OF max.	2.65 N {270 gf}
PT max.	0.4 mm
OT min.	1.6 mm
OP	28.2±0.5 mm

Reset Button

OF max.	2.79 N {285 gf}
OT min.	0.4 mm

Hinge Lever
Z-15EWR

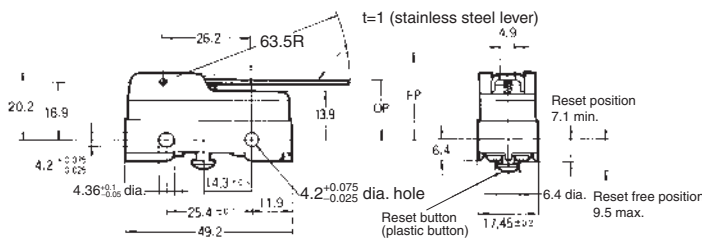
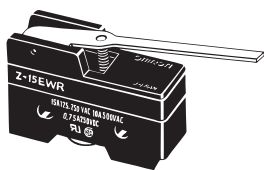

Lever Tip

OF max.	0.54 N {55 gf}
OT min.	5.6 mm
FP max.	28.2 mm
OP	19±0.8 mm

Reset Button

OF max.	2.94 N {0.3 gf}
OT min.	0.4 mm

■ Terminals

Basic Models (General-purpose) & Split-contact Models

Basic (General-purpose) Models		Split-contact Models
<p>Screw Terminals (-B)</p> <p>Three, M4 × 5.5 Terminal screws (with toothed washer)</p> <p>Appropriate terminal screw tightening torque: 0.78 to 1.18 N·m {8 to 12 kgf·cm}.</p> <p>Note: With reverse action models (Z-15GM), the positions of NO and NC terminals are reversed.</p>	<p>Solder Terminal</p> <p>Appropriate terminal screw tightening torque: 0.49 to 0.78 N·m {5 to 8 kgf·cm}.</p> <p>Note: With reverse action models (Z-10FM), the positions of NO and NC terminals are reversed.</p>	<p>Screw Terminals (Y-B)</p> <p>Five, M3.5 × 5.5 terminal screws (with toothed washer)</p> <p>Appropriate terminal screw tightening torque: 0.49 to 0.78 N·m {5 to 8 kgf·cm}.</p> <p>Note: With reverse action models (Z-10FM), the positions of NO and NC terminals are reversed.</p>

Basic Models (Drip-proof) without Terminal Protective Cover

Without Terminal Protective Cover

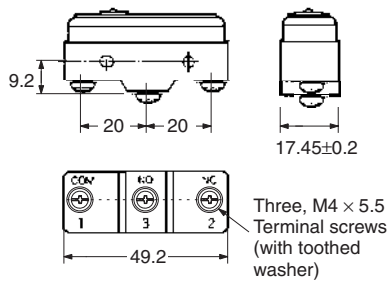

Note: With reverse action models (Z-15GM), the positions of NO and NC terminals are reversed.

Molded Terminals (Drip-proof Type/Molded Terminal)

Model Number Legend

Z-□55-M□□□M
 1 2 3 4

1. Drip-proof Type

2. Lead Outlets

None: VSF

19: VCT

3. Directions of Lead Outlets

Refer to the following diagrams.

4. Length of Lead Outlets

0.5: 0.5 m

1: 1 m

2: 2 m

3: 3 m

Contact Form

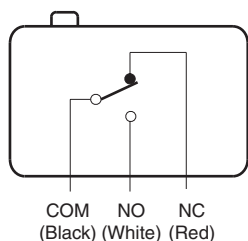

Note: With the reverse action model (Z-15GM), the positions of NO and NC terminals are reversed.

Dimensions

L/R Type

(The following illustration is the R type.)

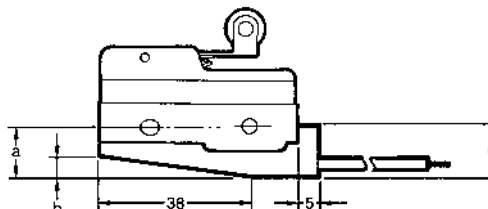

Lead wire	a	b	d
VSF	12	4	13
VCT	19	11	20

D Type

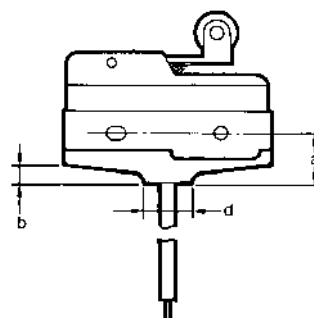

Lead wire	a	b	d
VSF	12	4	12
VCT	19	11	16

Lead Wire Specifications

Lead wire	Nominal cross-sectional area (mm ²)	Finished outer diameter (mm)	Connection to terminal	Length (m)
VSF (single-core, vinyl cord)	1.25	Approx. 3.1 dia.	Black: COM	0.5, 1, 2, 3
VCT (vinyl-insulated cable)		Three-core: approx. 10.5 dia.	White: NO Red: NC	

Note: No models with molded terminals are approved by UL, CSA, or TÜV.