

Small, High-precision Enclosed Switch

- Employs a modified version of Z Basic Switch as built-in switch.
- Same mounting pitch as Z Basic Switch.
- Pre-wired molded terminal models are available.
- Requires less operating force than conventional limit switches.
- Long life expectancy and economical.
- UL, CSA, and EN models are available.



Ordering Information

■ Model Number Legend













ZC-□55

1

1. Actuator

- D: Plunger
- Q: Panel mount plunger
- Q22: Panel mount roller plunger
- Q21: Panel mount crossroller plunger
- N22: Sealed roller plunger
- N21: Sealed crossroller plunger
- W: Short hinge lever
- W1: Hinge lever
- W2: Short hinge roller lever
- W21: Hinge roller lever
- W3: One-way action short hinge roller lever
- W31: One-way action hinge roller lever

■ List of Models

Actuator	Model	Actuator	Model
Plunger 	ZC-D55	Short hinge lever 	ZC-W55
Panel mount plunger 	ZC-Q55	Hinge lever 	ZC-W155
Panel mount roller plunger 	ZC-Q2255	Short hinge roller lever 	ZC-W255
Panel mount crossroller plunger 	ZC-Q2155	Hinge roller lever 	ZC-W2155
Sealed roller plunger 	ZC-N2255	One-way action short hinge roller lever 	ZC-W355
Sealed crossroller plunger 	ZC-N2155	One-way action hinge roller lever 	ZC-W3155

- Note:**
1. Use molded terminal models (refer to page 179) when using the Switch under one of the following conditions:
 - a) dusty, b) high amount of dripping oil, or c) high humidity
 2. Micro-load models are available.

e.g. <u>Standard model</u>	<u>Micro-load model</u>
ZC-Q55	ZC-Q55-01

Specifications

■ Ratings

Rated voltage	Non-inductive load				Inductive load			
	Resistive load		Lamp load		Inductive load		Motor load	
	NC	NO	NC	NO	NC	NO	NC	NO
125 VAC	10 A		3 A	1.5 A	10 A		5 A	2.5 A
250 VAC	10 A		2.5 A	1.25 A	10 A		3 A	1.5 A
8 VDC	10 A		3 A	1.5 A	6 A		5 A	2.5 A
14 VDC	10 A		3 A	1.5 A	6 A		5 A	2.5 A
30 VDC	6 A		3 A	1.5 A	5 A		5 A	2.5 A
125 VDC	0.5 A		0.4 A		0.05 A		0.05 A	
250 VDC	0.25 A		0.2 A		0.03 A		0.03 A	

Inrush current	NC	30 A max.
	NO	15 A max.

- Note:**
1. The above figures are for steady-state currents.
 2. Inductive loads have a power factor of 0.4 min. (AC) and a time constant of 7 ms max. (DC).
 3. Lamp load has an inrush current of 10 times the steady-state current.
 4. Motor load has an inrush current of 6 times the steady-state current.
 5. The above ratings were tested under the following conditions according to JIS C4508.
 Ambient temperature: 20±2°C
 Ambient humidity: 65±5%
 Operating frequency: 20 operations/min

■ Approved Standard Ratings

UL/CSA
A300

Voltage	Carry current	Current		Volt-amperes	
		Make	Break	Make	Break
120 VAC	10 A	60 A	6 A	7,200 VA	720 VA
240 VAC		30 A	3 A		

0.5 A 125 VDC, 0.25 A 250 VDC

Micro load: 0.1 A, 125 VAC
0.1 A, 30 VDC

EN60947-1 and EN60947-5-1

250 V, 10 A (AC-12)

■ Characteristics

Degree of protections	IP67 (NEMA 250:6, 6P)
Life expectancy	Mechanical: 10,000,000 operations min. Electrical: 500,000 operations min.
Operating speed	0.05 mm to 0.5 m/s (at pin plunger)
Operating frequency	Mechanical: 120 operations/min Electrical: 20 operations/min
Insulation resistance	100 MΩ min. (at 500 VDC)
Contact resistance	15 mΩ max. (initial value)
Dielectric strength	1,000 VAC, 50/60 Hz for 1 min between non-continuous terminals 2,000 VAC, 50/60 Hz for 1 min between current-carrying metal part and ground, and between each terminal and non-current-carrying metal parts
Rated insulation voltage (U _i)	1,000 VAC
Pollution degree (operating environment)	3 (IEC947-5-1)
PT1 (tracking characteristics)	175
Switch category	D (IEC335)
Rated operating current (I _e)	10 A
Rated operating voltage (U _e)	250 VAC
Vibration resistance	Malfunction: 10 to 55 Hz, 1.5-mm double amplitude (see note)
Shock resistance	Destruction: 1,000 m/s ² Malfunction: 300 m/s ² (see note)
Ambient temperature	Operating: -10°C to 80°C (with no icing)
Ambient humidity	Operating: 35% to 95%
Weight	Approx. 92 g (in case of ZC-Q22(21)55)

Note: Less than 1 ms under a free state at the operating limits.

Contact Form

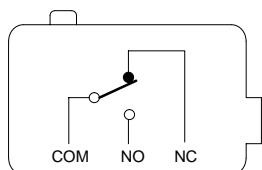

■ Operating Characteristics

Model	ZC-D55	ZC-Q55	ZC-Q2255	ZC-Q2155	ZC-N2255	ZC-N2155
OF max.	11.8 N	11.8 N			6.86 N	
RF min.	4.90 N	4.90 N			1.67 N	
PT max.	1.5 mm	1.5 mm			1.5 mm	
OT min.	2.4 mm	3 mm			2.5 mm	
MD max.	0.2 mm	0.2 mm			0.2 mm	
OP	32.4±0.8 mm	38.2±0.8 mm	47.4±0.8 mm			

Model	ZC-W55	ZC-W155	ZC-W255	ZC-W2155	ZC-W355	ZC-W3155
OF max.	3.92 N	2.75 N	3.92 N	2.75 N	3.92 N	2.75 N
RF min.	0.78 N	0.59 N	0.78 N	0.59 N	0.78 N	0.59 N
OT min.	6 mm	8.4 mm	6 mm	8.4 mm	6 mm	8.4 mm
MD max.	1 mm	1.4 mm	1 mm	1.4 mm	1 mm	1.4 mm
OP	28.5±1.2 mm	28.5±1.2 mm	43±1.2 mm	43±1.2 mm	53±1.2 mm	53±1.2 mm
FP max.	34.7 mm	36.7 mm	49.2 mm	51.3 mm	59.2 mm	61.2 mm

■ Approved Standards

(Except Molded Terminal Models and Operation Indicator-equipped Model)

UL (File No. E76675)/CSA (File No. E45258)

TÜV (No. J9650089)

EN60947-1, EN60947-5-1

Engineering Data

Mechanical Life Expectancy (for ZC-Q55)

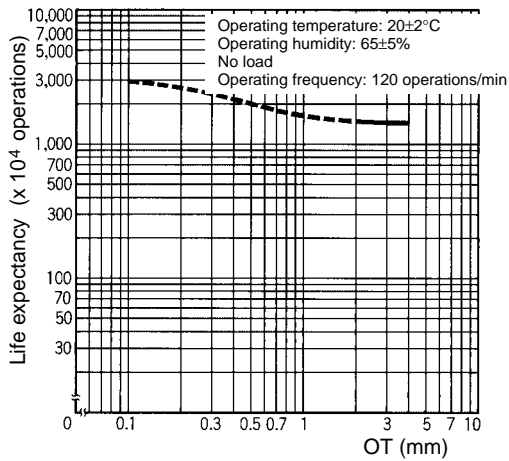

Electrical Life Expectancy

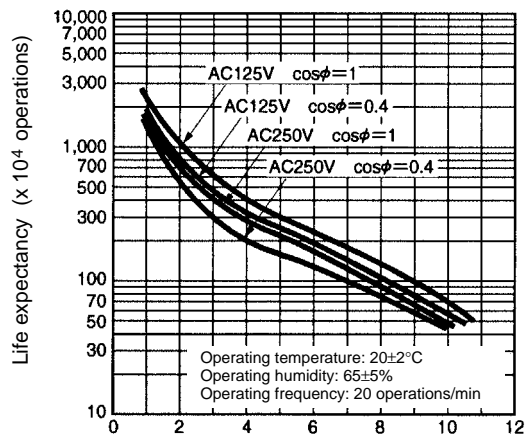

Dimensions

- Note:**
1. All units are in millimeters unless otherwise indicated.
 2. Unless otherwise specified, a tolerance of ±0.4 mm applies to all dimensions.

**Plunger
ZC-D55**

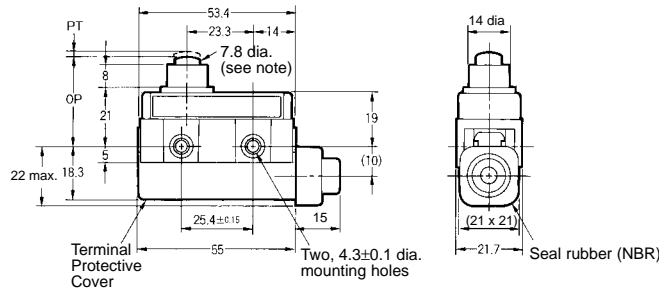

Note: Stainless steel plunger

**Panel Mount Plunger
ZC-Q55**

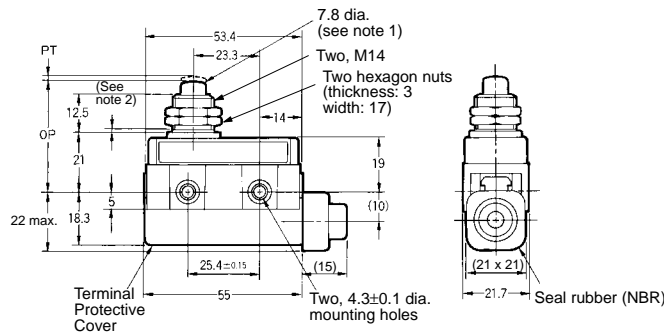

- Note:**
1. Stainless steel plunger
 2. The length of the imperfect threads is 1.5 mm maximum.

**Panel Mount Roller Plunger
ZC-Q2255**

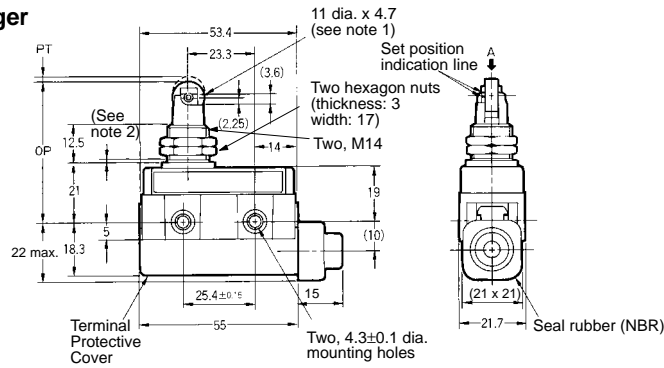

- Note:**
1. Stainless steel roller
 2. The length of the imperfect threads is 1.5 mm maximum.

**Panel Mount Crossroller Plunger
ZC-Q2155**

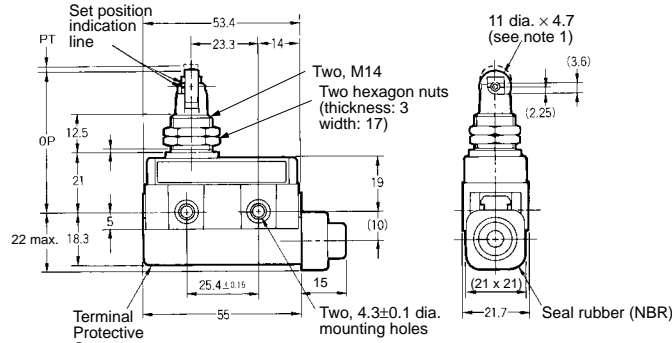

- Note:**
1. Stainless steel roller
 2. The length of the imperfect threads is 1.5 mm maximum.

**Sealed Roller Plunger
ZC-N2255**

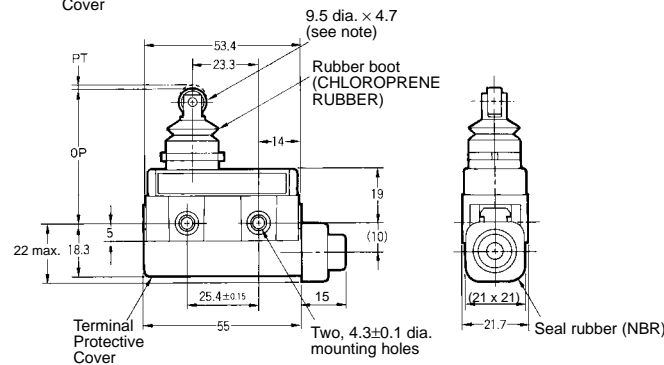

- Note:** Stainless steel roller

**Sealed Crossroller Plunger
ZC-N2155**

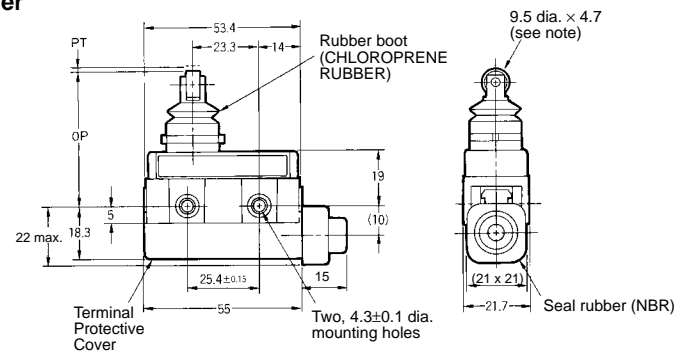

- Note:** Stainless steel roller

**Short Hinge Roller Lever
ZC-W55**

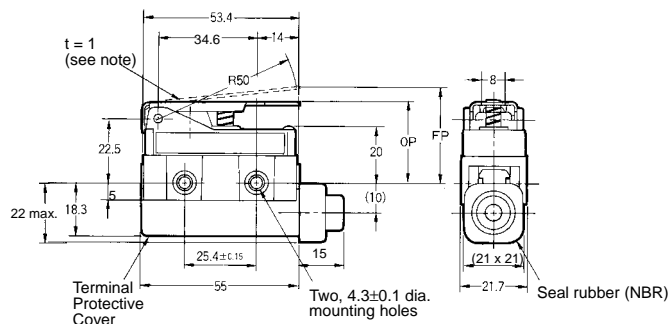

- Note:** Stainless steel lever

**Hinge Lever
ZC-W155**

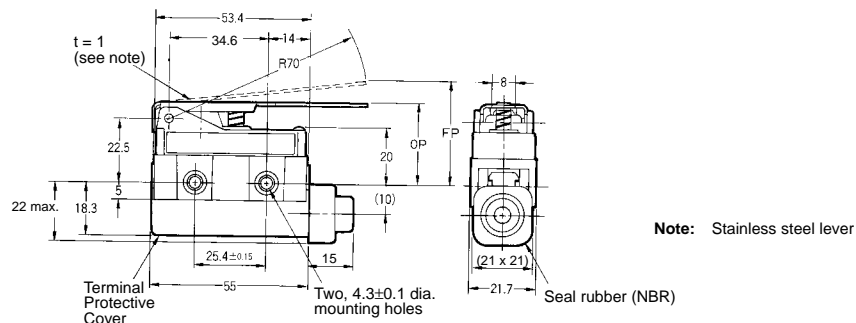

Note: Stainless steel lever

**Short Hinge Roller Lever
ZC-W255**

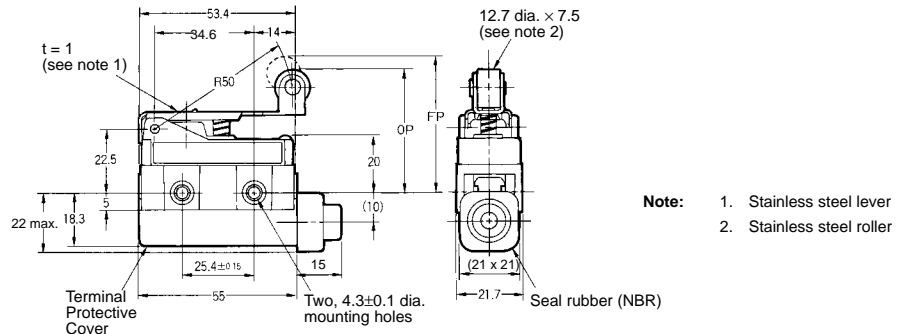

Note: 1. Stainless steel lever
2. Stainless steel roller

**Hinge Roller Lever
ZC-W2155**

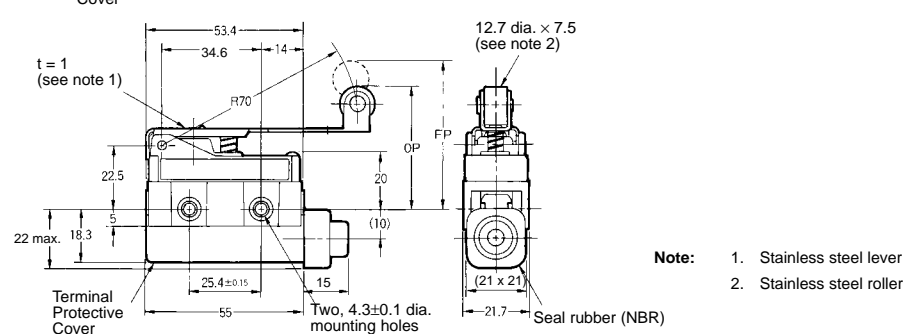

Note: 1. Stainless steel lever
2. Stainless steel roller

**One-way Action Short Hinge Roller Lever
ZC-W355**

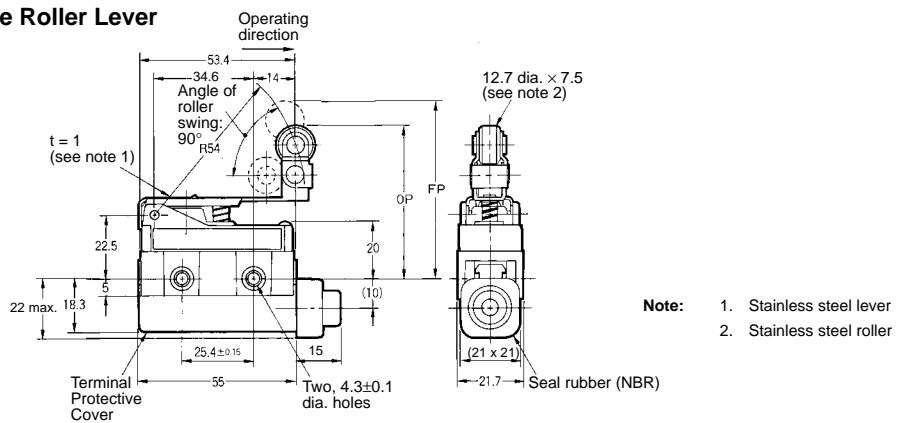

Note: 1. Stainless steel lever
2. Stainless steel roller

**One-way Action Hinge Roller Lever
ZC-W3155**

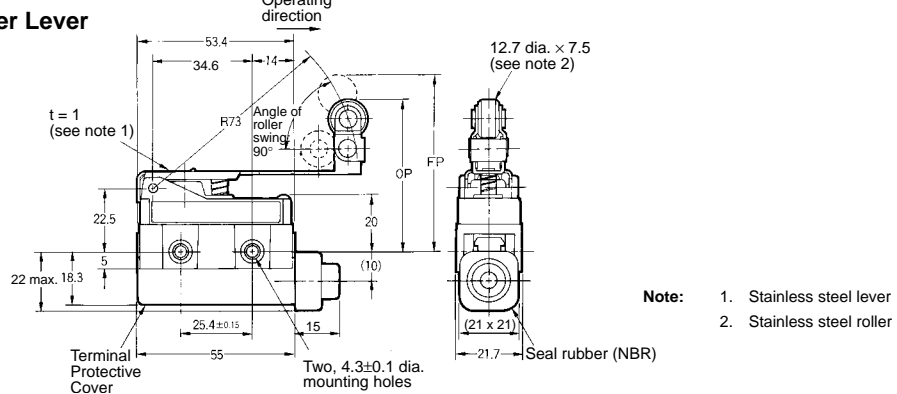

Note: 1. Stainless steel lever
2. Stainless steel roller

Mounting Holes

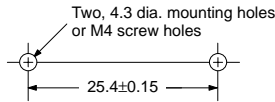

Molded Terminal Models

■ Molded Terminal Model

The molded-terminal model is available with right-hand, left-hand and underside leads and is recommended for use where the Switch is exposed to dust, oil or moisture.

The molded-terminal model is not approved by UL and CSA.

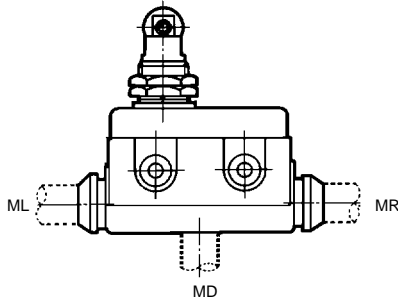

Note: When placing your order for the Switch, specify the required length of V.C.T. cable in addition to the model number of the Switch.

Example:

Standard type: ZC-Q2155

Location of lead output: Underside

Length of lead: 1 m (V.C.T. lead)

When placing your order for the above Switch, specify the model number as ZC-Q2155-MD (VCT 1 m).

Suffix by Location of Lead Outlet

Location of lead output	Model
	COM, NC and NO
Right-hand	ZC-□-MR
Left-hand	ZC-□-ML
Underside	ZC-□-MD

Lead Supplies

Leads	Nominal cross-sectional area	No. of component wires/ component wire diameter	Finished outside diameter	Terminal connections	Standard length
V.C.T. (vinyl cabtire cable)	1.25 mm ²	50/0.18 dia.	Triple conductor: 10.5 dia.	Black: COM White: NO Red: NC	1, 3, 5 m

■ Operation Indicator-equipped Model

All the models can be equipped upon request with a operation indicator to facilitate maintenance and inspection.

Because the indicator is incorporated in the Terminal Protective Cover, the dimensions of the Limit Switch are not affected. In this model, the lead wire is to be connected to the screw terminal. (A connecting washer is provided on the tip of the lead wire).

The lead wire can be connected to either the NC or NO terminal.

Operating characteristics are the same as the standard model from which the operation indicator equipped model is fabricated.

AC Operation

The operating voltage range is from 90 to 250 VAC.

The dimensions are the same as the standard type. The top of the Terminal Protective Cover is transparent to allow checking the operation easily.

When placing your order for the indicator equipped, AC-operated model, add suffix "L" to the end of the model number.

Example:

Standard type: ZC-Q2255
Indicator equipped type: ZC-Q2255-L

Contact Circuit

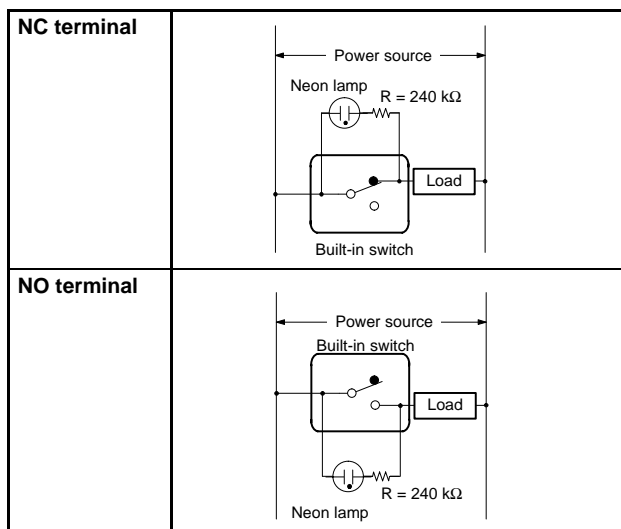

Note: If the wiring is as shown above, the operation of the respective parts will be as follows:

Contact	Neon lamp	Load	Actuator
NC	ON	Does not operate	Operates
	OFF	Operates	Does not operate
NO	ON	Does not operate	Does not operate
	OFF	Operates	Operates

DC Operation

The DC-operated is provided with an LED indicator.

Since a rectifier stack is incorporated into the unit to permit reversing the polarity, this type can also operate on AC power source.

The LED projects from the housing for easy visibility.

When placing your order, add suffix "L2" to "L5" to the model number of the standard type.

Example:

Standard type: ZC-Q2255
Indicator equipped type: ZC-Q2255-L2

Type	Voltage rating	Leakage current	Internal resistance
L2	12 V	Approx. 2.4 mA	4.3 kΩ
L4	24 V	Approx. 1.2 mA	18 kΩ

Contact Circuit

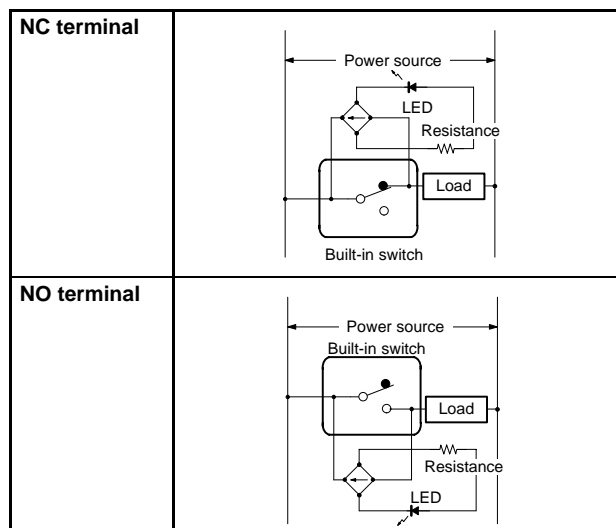

Note: If the wiring is as shown above, the operation of the respective parts will be as follows:

Contact	LED	Load	Actuator
NC	ON	Does not operate	Operates
	OFF	Operates	Does not operate
NO	ON	Does not operate	Does not operate
	OFF	Operates	Operates

Precautions

■ Correct Use

Dog Angle

When operating the roller type, be sure to set the dog angle to less than 30° (even when operating at a low speed). Operating the model at a dog angle exceeding 30° will soon cause abrasion or damage. Do not apply a twisting force to the plunger. Set the OT to 70% to 100% of the specified value so that the actuator will not exceed the OT.

Handling

When detaching the Terminal Protective Cover, insert a screwdriver and apply a force in the opening direction. Do not use excess force to remove the cover. Doing so may cause deformation in the fitting section and reduce the holding force.

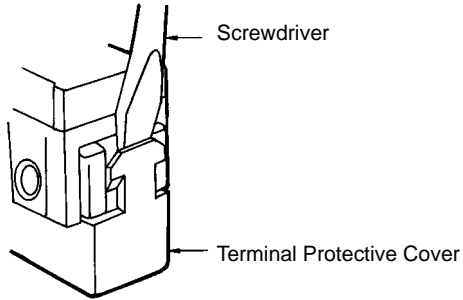

When mounting the Terminal Protective Cover to the case, align the cover on the case and then press the cover down to mount it firmly. If the cover is pressed down in an inclined position, rubber packing will deform and thus affect the sealing capability.

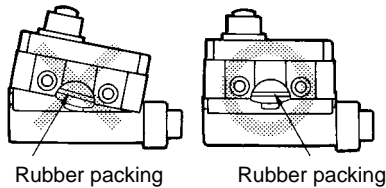

- A 8.5- to 10.5-dia. cable can be applied as seal rubber for the lead wire outlet. (Use two- or three-core cable of VCT1.25 mm².)
- Use weather-proof rubber (chloroprene rubber) as seal rubber for the ZC-N22(21)55.

Mounting

- When mounting the Switch with screws on a side surface, fasten the Switch with M4 screws and use washers, spring washers, etc., to ensure secure mounting.

Mounting Holes

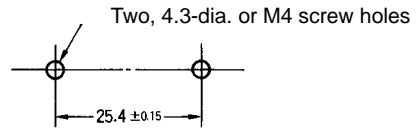

- When mounting the Panel Mount-type Enclosed Switch (ZC-Q55, ZC-Q2255, or ZC-Q2155) with screws on a side surface, remove the hexagonal nuts from the actuator.

Mounting Hole Dimensions

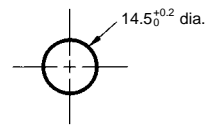

Correct Tightening Torque

A loose screw may result in a malfunction. Be sure to tighten each screw to the proper tightening torque as shown below.

No.	Type	Torque
1	Terminal screw	0.78 to 1.18 N • m
2	Panel mounting screw	4.90 to 7.84 N • m
3	Side mounting screw	1.18 to 1.47 N • m

Operation

With the ZC-Q22(21)55, an appropriate OT line is marked on the plunger. Set the OT so that it is between the two X-surface lines.

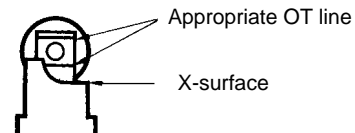

ALL DIMENSIONS SHOWN ARE IN MILLIMETERS.

To convert millimeters into inches, multiply by 0.03937. To convert grams into ounces, multiply by 0.03527.